

FXTH870x6, Tire Pressure Monitor Sensor

The FXTH870x6 family is comprised of the following functions all within the same package.

Features

- Pressure sensor with one of two calibrated pressure ranges
 - 100 - 450 kPa
 - 100 - 900 kPa
- Temperature sensor
- Optional XZ- or Z-axis accelerometer with adjustable offset option
- Voltage reference measured by ADC10
- Six-channel, 10-bit analog-to-digital converter (ADC10) with two external I/O inputs
- 8-bit MCU
 - S08 Core with SIM and interrupt
 - 512 RAM
 - 8K FLASH (in addition to 8K providing factory firmware and trim data)
 - 64-byte, low-power, parameter registers
- Dedicated state machines to sequence routine measurement and transmission processes for reduced power consumption
- Internal 315-/434-MHz RF transmitter
 - External crystal oscillator
 - PLL-based output with fractional-n divider
 - OOK and FSK modulation capability
 - Programmable data rate generator
 - Manchester, Bi-Phase or NRZ data encoding
 - 256-bit RF data buffer variable length interrupt
 - Direct access to RF transmitter from MCU for unique formats
 - Low power consumption (less than 8 mA at 434 MHz, 5 dBm at 3.0 V, 25 °C)
- Differential input LF detector/decoder on independent signal pins
- Seven multipurpose GPIO pins
 - Four pins can be connected to optional internal pullups/pulldowns and STOP4 wakeup interrupt
 - Two of seven pins can be connected to a channel on the ADC10
 - Two of seven pins can be connected to a channel on the TPM1
- Real-Time Interrupt driven by LFO with interrupt intervals of 8, 16, 32, 64, 128, 256, 512 or 1024 ms
- Low-power, wakeup timer and periodic reset driven by LFO
- Watchdog timeout with selectable times and clock sources
- Two-channel general purpose timer/PWM module (TPM1)
- Internal oscillators

FXTH870x6

Top and bottom view

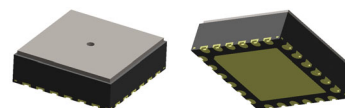

24-Pin, 1-hole lid
7 x 7 QFN

Top view

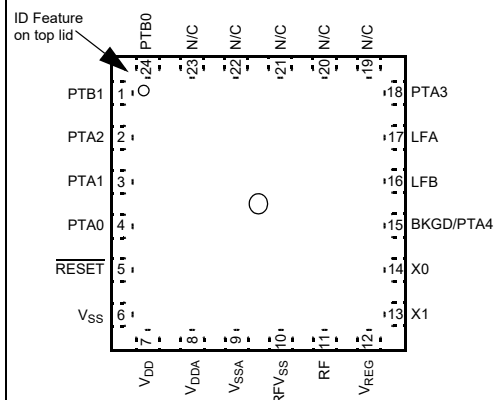

Pin connections

- MCU bus clock of 0.5, 1, 2 and 4 MHz (1, 2, 4 and 8 MHz HFO)
- Low frequency, low power time clock (LFO) with 1 ms period
- Medium frequency, controller clock (MFO) of 8 μ sec period
- Low-voltage detection
- Normal temperature restart in hardware (over- or under-temperature detected by software)

ORDERING INFORMATION					
Part number	Accelerometer axis	Package	Range	Code1	
FXTH8705026T1	Z	2264 (7 x 7, 1-hole lid)	100-450 kPa	\$08	
FXTH8705116T1	XZ	2264 (7 x 7, 1-hole lid)	100-450 kPa	\$0C	
FXTH8709026T1	Z	2264 (7 x 7, 1-hole lid)	100-900 kPa	\$18	
FXTH8709116T1	XZ	2264 (7 x 7, 1-hole lid)	100-900 kPa	\$1C	
FXTH8709126T1	XZ Ext. Range	2264 (7 x 7, 1-hole lid)	100-900 kPa	\$1E	
				Code1	Code0
FXTH8709226T1	XZ	2264 (7 x 7, 1-hole lid)	100-900 kPa	\$1C	Rel11

Contents

1	General Information	6
1.1	Overall Block Diagram	6
1.2	Multi-Chip Interface	6
1.3	System Clock Distribution	6
1.4	Reference Documents	8
2	Pins and Connections	9
2.1	Package Pinout	9
2.2	Recommended Application	10
2.3	Signal Properties	10
3	Modes of Operation	13
3.1	Features	13
3.2	RUN Mode	13
3.3	WAIT Mode	13
3.4	ACTIVE BACKGROUND Mode	13
3.5	STOP Modes	14
4	Memory	17
4.1	MCU Memory Map	17
4.2	Reset and Interrupt Vectors	17
4.3	MCU Register Addresses and Bit Assignments	18
4.4	High Address Registers	22
4.5	MCU Parameter Registers	22
4.6	MCU RAM	22
4.7	FLASH	23
4.8	Security	28
4.9	FLASH Registers and Control Bits	29
5	Reset, Interrupts and System Configuration	33
5.1	Features	33
5.2	MCU Reset	33
5.3	Computer Operating Properly (COP) Watchdog	33
5.4	SIM Test Register (SIMTST)	34
5.5	Interrupts	35
5.6	Low-Voltage Detect (LVD) System	38
5.7	System Clock Control	38
5.8	Keyboard Interrupts	38
5.9	Real Time Interrupt	39
5.10	Temperature Sensor and Restart System	40
5.11	Reset, Interrupt and System Control Registers And Bits	40
5.12	System STOP Exit Status Register (SIMSES)	45
6	General Purpose I/O	46
6.1	Unused Pin Configuration	48
6.2	Pin Behavior in STOP Modes	48
6.3	General Purpose I/O Registers	48
6.4	Port A Registers	48
6.5	Port B Registers	49
7	Keyboard Interrupt	51
7.1	Features	51
7.2	Modes of Operation	51
7.3	Block Diagram	51
7.4	External Signal Description	51
7.5	Register Definitions	52
7.6	Functional Description	53
8	Central Processing Unit	54
8.1	Introduction	54
8.2	Features	54
8.3	Programmer's Model and CPU Registers	55
8.4	Addressing Modes	57
8.5	Special Operations	58
8.6	HCS08 Instruction Set Summary	59

9	Timer Pulse-Width Module	70
9.1	Features	70
9.2	TPM1 Configuration Information	70
9.3	External Signal Description	71
9.4	Register Definition	72
9.5	Functional Description	77
9.6	TPM1 Interrupts	80
10	Other MCU Resources	82
10.1	Pressure Measurement	82
10.2	Temperature Measurements	83
10.3	Voltage Measurements	83
10.4	Optional Acceleration Measurements	83
10.5	Optional Battery Condition Check	83
10.6	Measurement Firmware	85
10.7	Thermal Shutdown	87
11	Periodic Wakeup Timer	89
11.1	Block Diagram	89
11.2	Wakeup Divider Register - PWUDIV	90
11.3	PWU Control/Status Register 0 - PWUCS0	90
11.4	PWU Control/Status Register 1 - PWUCS1	91
11.5	PWU Wakeup Status Register - PWUS	92
11.6	Functional Modes	92
12	LF Receiver	93
12.1	Features	94
12.2	Modes of Operation	94
12.3	Power Management	94
12.4	Input Amplifier	95
12.5	LFR Data Mode States	95
12.6	Carrier Detect	95
12.7	Auto-Zero Sequence	97
12.8	Data Recovery	97
12.9	Data Clock Recovery and Synchronization	97
12.10	Manchester Decode	97
12.11	Duty-Cycle For Data Mode	98
12.12	Input Signal Envelope	99
12.13	Telegram Verification	100
12.14	Error Detection and Handling	101
12.15	Continuous ON Mode	101
12.16	Initialization Information	101
12.17	LFR Register Definition	102
13	RF Module	113
13.1	RF Data Modes	113
13.2	RF Output Buffer Data Frame	114
13.3	Transmission Randomization	116
13.4	RFM in STOP1 Mode	119
13.5	Data Encoding	119
13.6	RF Output Stage	121
13.7	RF Interrupt	122
13.8	Datagram Transmission Times	122
13.9	RFM Registers	123
13.10	RFM Control Register 1 - RFCR1	123
13.11	RFM Control Register 2 - RFCR2	124
13.12	RFM Control Register 3 - RFCR3	127
13.13	RFM Control Register 4 - RFCR4	128
13.14	RFM Control Register 5 - RFCR5	128
13.15	RFM Control Register 6 - RFCR6	129
13.16	RFM Control Register 7 - RFCR7	129
13.17	PLL Control Registers A- PLLCR[1:0], RPAGE = 0	130
13.18	PLL Control Registers B- PLLCR[3:2], RPAGE = 0	131
13.19	EPR Register - EPR (RPAGE = 1)	132
13.20	RF DATA Registers - RFD[31:0]	133
13.21	VCO Calibration Machine	134

14	Firmware	135
14.1	Software Jump Table	135
14.2	Function Documentation	135
14.3	Memory Resource Usage	140
15	Development Support	141
15.1	Introduction	141
15.2	Background Debug Controller (BDC)	141
15.3	Register Definition	146
16	Battery Charge Consumption Modeling	149
16.1	Standby Current	149
16.2	Measurement Events	149
16.3	Transmission Events	149
16.4	Total Consumption	149
17	Electrical Specifications	150
17.1	Maximum Ratings	150
17.2	Operating Range	150
17.3	Electrical Characteristics	151
17.4	Power Consumption (MCU)	152
17.5	Control Timing	153
17.6	Voltage Measurement Characteristics	154
17.7	Temperature Measurement Characteristics	155
17.8	Pressure Measurement Characteristic (100 to 450 kPa ranges)	156
17.9	Pressure Measurement Characteristic (100 to 900 kPa ranges)	157
17.10	Optional Acceleration Sensor Characteristics	158
17.11	LFR Sensitivity	161
17.12	LFR Characteristics	162
17.13	LFR Power Consumption	162
17.14	RF Output Stage	164
17.15	Power Consumption RF Transmissions	166
18	Mechanical Specifications	168
18.1	Maximum Ratings	168
18.2	Media Compatibility	168
18.3	Mounting Recommendations	168
19	Package Outline	170
20	Revision History	173

Related documentation

The FXTH870x6 device features and operations are described in a variety of reference manuals, user guides, and application notes. To find the most-current versions of these documents:

1. Go to the NXP homepage at:

<http://www.nxp.com/>
2. In the ALL search box at the top of the page, enter the device family FXTH87.
3. Go to the Documents tab.

1 General Information

1.1 Overall Block Diagram

The block diagram of the FXTH870x6 is shown in [Figure 1](#). This diagram covers all the main blocks mentioned above and their main signal interactions. Power management controls and bus control signals are not shown in this block diagram for clarity.

1.2 Multi-Chip Interface

The FXTH870x6 contains two to three devices using the best process technology for each.

- Microcontroller with accelerometer and pressure sensor interfaces, and RF transmitter (MCU)
- Optional ranges on pressure transducers
- Optional XZ- or Z-axis acceleration transducer

As shown in [Figure 1](#) the MCU interfaces to the RF transmitter using a standard memory mapped registers. The transducers connect to the MCU using custom analog interfaces and inter-chip bonding wires.

1.3 System Clock Distribution

The various clock sources and their distribution are shown in [Figure 2](#). All clock sources except the low frequency oscillator, LFO, can be turned off by software control in order to conserve power.

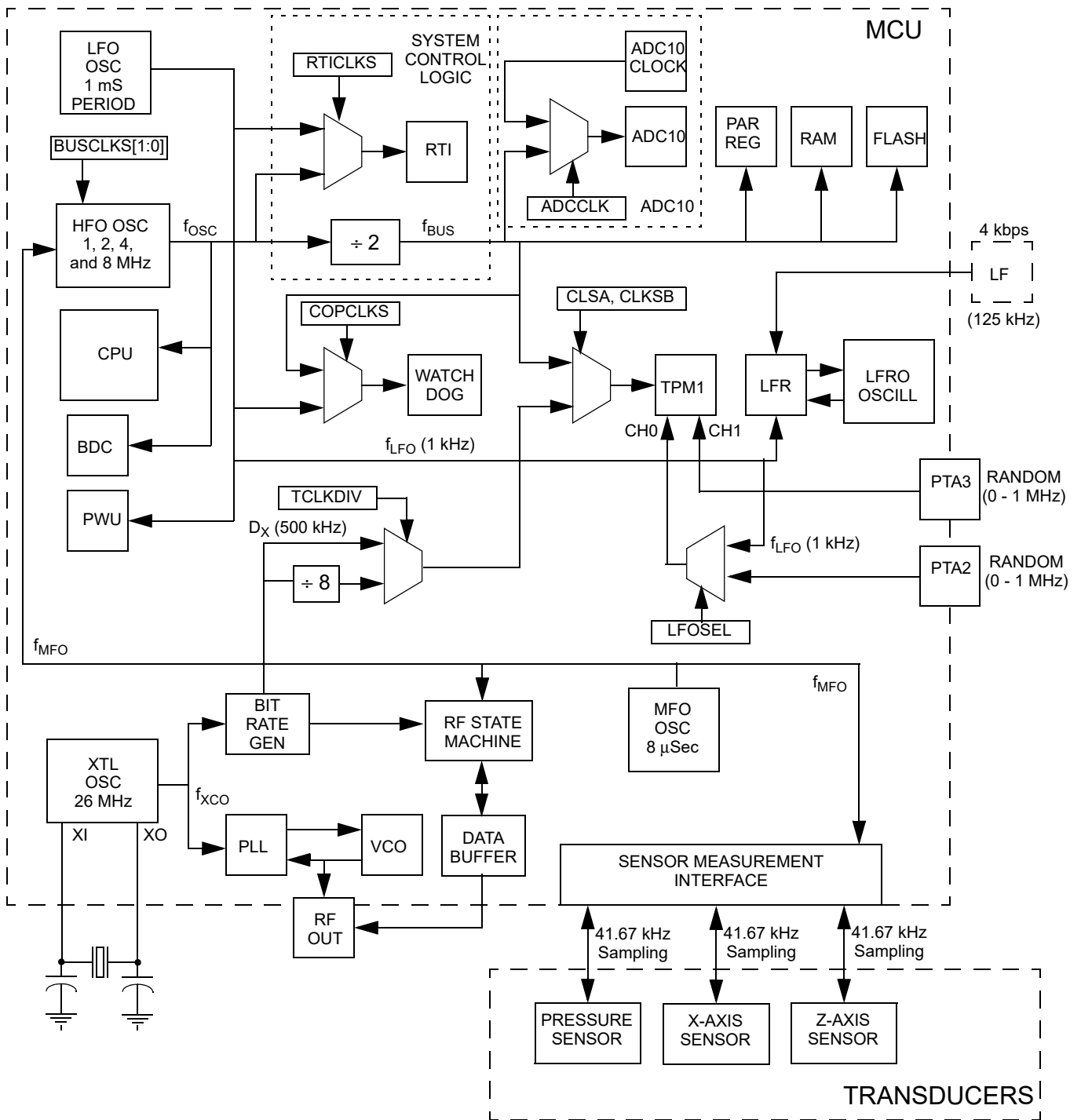

Figure 2. Clock Distribution

1.4 Reference Documents

The FXTH870x6 utilizes the standard product MC9S08 CPU core. The user can obtain further detail on the full capabilities of this core by referring to the HCS08 Family Reference Manual (HCS08RMV1).

2 Pins and Connections

This section describes the pin layout and general function of each pin.

2.1 Package Pinout

The pinout for the FXTH870x6 device QFN package is shown in Figure 3 for the orientation of the pressure port up. The orientation of the internal Z-axis accelerometer is shown in Figure 4.

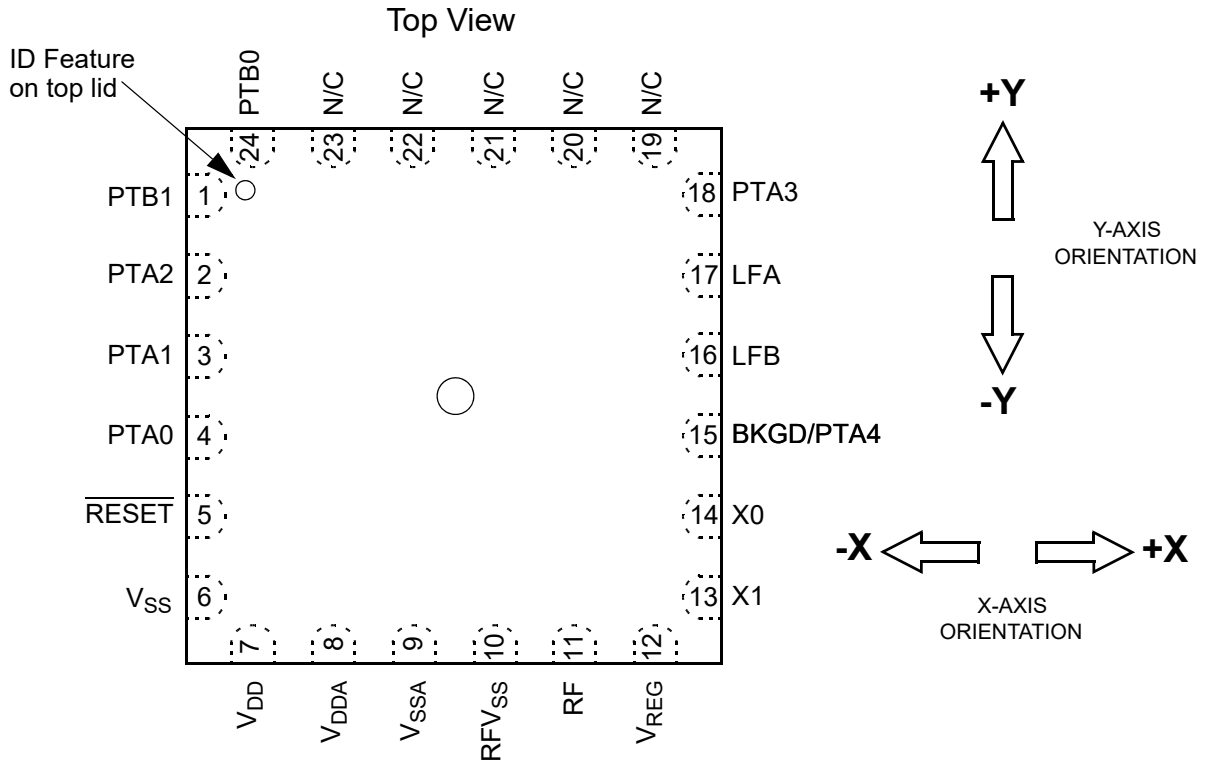

N/C = No Connect: Do not connect PCB pads to signal traces, power/ground or multi-layer via.

Figure 3. FXTH870x6 QFN Package Pinout

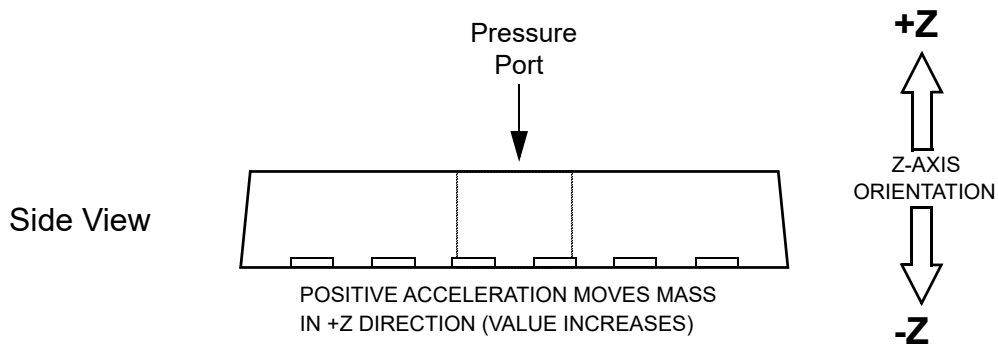

Figure 4. FXTH870x6 QFN Optional Z-axis Accelerometer Orientation

2.2 Recommended Application

Example of a simple OOK/FSK tire pressure monitors using the internal PLL-based RF output stage is shown in Figure 5. Any of the PTA[3:0] pins can also be used as general purpose I/O pins. Any of the PTA[3:0] pins that are not used in the application should be handled as described in Section 6.1.

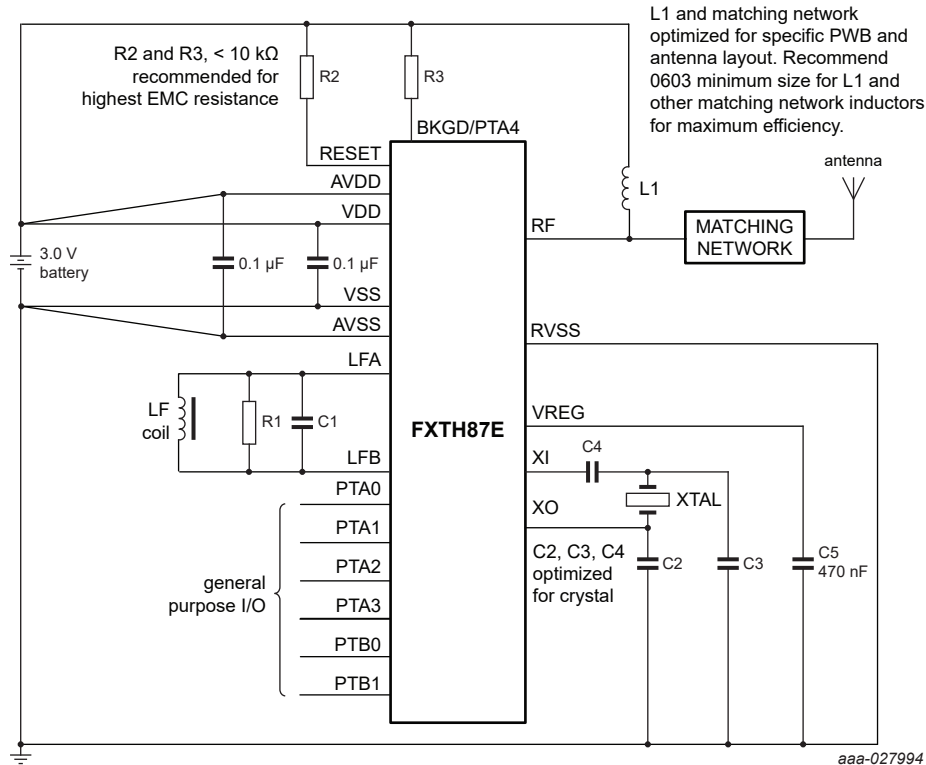

Figure 5. FXTH870x6 Example Application

The device labeled C4 in Figure 5, is drawn as a capacitor but may be any type of passive component(s) sufficient to block or reduce unwanted external radiated signals from corrupting the crystal oscillator circuit: PCB traces for the LFA/LFB, AVDD/VDD, and VSS/AVSS pins and bypass capacitors should be minimized to reduce unwanted external radiated signals from corrupting the power input circuits.

Care must be taken by the application to ensure the pressure applied to all surfaces of the sensor remains equal. The sensor is constructed from nonhermetic materials and should not be used as a seal between the tire pressure and the ambient environment pressure. The seal should be provided by the final module design and not by the surfaces of the sensor.

NOTE: A gel is used to provide media protection against corrosive elements which may otherwise damage metal bond wires and/or IC surfaces. Highly pressurized gas molecules may permeate through the gel and then occupy boundaries between material surfaces within the sensor package. When decompression occurs, the gas molecules may collect, form bubbles and possibly result in delamination of the gel from the material it protects. If a bubble is located on the pressure transducer surface or on the bond wires, the sensor measurement may shift from its calibrated transfer function. In some cases, these temporary shifts could be outside the tolerances listed in this data sheet. In rare cases, the bubble may bend the bond wires and result in a permanent shift.

2.3 Signal Properties

The following sections describe the general function of each pin.

2.3.1 V_{DD} and V_{SS} Pins

The digital circuits operate from a single power supply connected to the FXTH870x6 through the V_{DD} and V_{SS} pins. V_{DD} is the positive supply and V_{SS} is the ground. The conductors to the power supply should be connected to the V_{DD} and V_{SS} pins and locally decoupled as shown in Figure 6.

Care should be taken to reduce measurement signal noise by separating the V_{DD}, V_{SS}, AV_{DD}, AV_{SS} and RV_{SS} pins using a “star” connection such that each metal trace does not share any load currents with other external devices as shown in Figure 6.

2.3.2 AV_{DD} and AV_{SS} Pins

The analog circuits operate from a single power supply connected to the FXTH870x6 through the AV_{DD} and AV_{SS} pins. AV_{DD} is the positive supply and AV_{SS} is the ground. The conductors to the power supply should be connected to the AV_{DD} and AV_{SS} pins and locally decoupled as shown in Figure 6.

Care should be taken to reduce measurement signal noise by separating the V_{DD}, V_{SS}, AV_{DD}, AV_{SS} and RV_{SS} pins using a “star” connection such that each metal trace does not share any load currents with other external devices as shown in Figure 6.

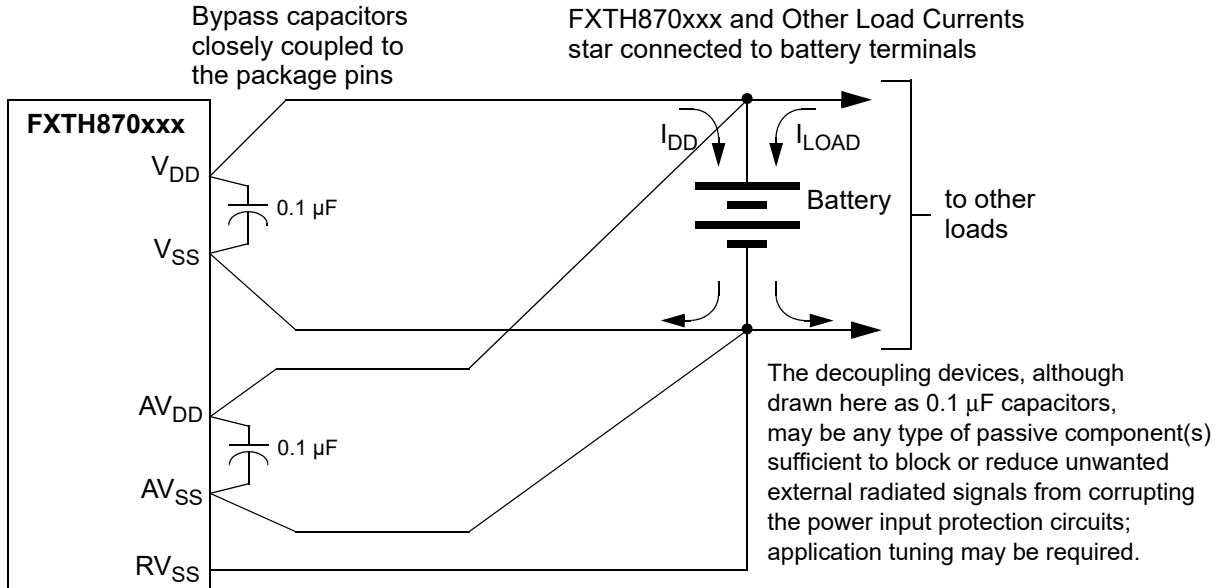

Figure 6. Recommended Power Supply Connections

2.3.3 V_{REG} Pin

The internal regulator for the analog circuits requires an external stabilization capacitor to AV_{SS}.

2.3.4 RV_{SS} Pin

Power in the RF output amplifier is returned to the supply through the RV_{SS} pin. This conductor should be connected to the power supply as shown in Figure 6 using a “star” connection such that each metal trace does not share any load currents with other supply pins.

2.3.5 RF Pin

The RF pin is the RF energy data supplied by the FXTH870x6 to an external antenna.

2.3.6 XO, XI Pins

The XO and XI pins are for an external crystal to be used by the internal PLL for creating the carrier frequencies and data rates for the RF pin.

2.3.7 LF[A:B] Pins

The LF[A:B] pins can be used by the LF receiver (LFR) as one differential input channel for sensing low level signals from an external low frequency (LF) coil. The external LF coil should be connected between the LFA and the LFB pins.

Signaling into the LFR pins can place the FXTH870x6 into various diagnostic or operational modes. The LFR is comprised of the detector and the decoder.

Each LF[A:B] pin will always have an impedance of approximately 500 k Ω to V_{SS} due to the LFR input circuitry. The LFA/LFB pins are used by the LFR when the LFEN control bit is set and are not functional when the LFEN control bit is clear.

2.3.8 PTA[1:0] Pins

The PTA[1:0] pins are general purpose I/O pins. These two pins can be configured as normal bidirectional I/O pins with programmable pullup or pulldown devices and/or wakeup interrupt capability; or one or both can be connected to the two input

channels of the A/D converter module. The pulldown devices can only be activated if the wakeup interrupt capability is enabled. User software must configure the general purpose I/O pins so that they do not result in “floating” inputs as described in [Section 6.1](#). PTA[1:02] map to keyboard Interrupt function bits [1:0].

2.3.9 PTA[3:2] Pins

The PTA[3:2] pins are general purpose I/O pin. These two pins can be configured as normal bidirectional I/O pin with programmable pullup or pulldown devices and/or wakeup interrupt capability; or one or both can be connected to the two input channels of the Timer Pulse Width (TPM1) module. The pulldown devices can only be activated if the wakeup interrupt capability is enabled. User software must configure the general purpose I/O pins so that they do not result in “floating” inputs as described in [Section 6.1](#). PTA[3:2] map to keyboard Interrupt function bits [3:2].

2.3.10 BKGD/PTA4 Pin

The BKGD/PTA4 pin is used to place the FXTH870x6 in the BACKGROUND DEBUG mode (BDM) to evaluate MCU code and to also transfer data to/from the internal memories. If the BKGD/PTA4 pin is held low when the FXTH870x6 comes out of a power-on reset the device will go into the ACTIVE BACKGROUND DEBUG mode (BDM).

The BKGD/PTA4 pin has an internal pullup device and can connected to V_{DD} in the application unless there is a need to enter BDM operation after the device as been soldered into the PWB. If in-circuit BDM is desired the BKGD/PTA4 pin can be left unconnected, but should be connected to V_{DD} through a low impedance resistor ($< 10\text{ k}\Omega$) which can be over-driven by an external signal. This low impedance resistor reduces the possibility of getting into the debug mode in the application due to an EMC event.

2.3.11 $\overline{\text{RESET}}$ Pin

The $\overline{\text{RESET}}$ pin is used for test and establishing the BDM condition and providing the programming voltage source to the internal FLASH memory. This pin can also be used to direct to the MCU to the reset vector as described in [Section 5.2](#).

The $\overline{\text{RESET}}$ pin has an internal pullup device and can connected to V_{DD} in the application unless there is a need to enter BDM operation after the device as been soldered to the PWB. If in-circuit BDM is desired the $\overline{\text{RESET}}$ pin can be left unconnected; but should be connected to V_{DD} through a low impedance resistor ($< 10\text{ k}\Omega$) which can be over-driven by an external signal. This low impedance resistor reduces the possibility of getting into the debug mode in the application due to an EMC event.

Activation of the external reset function occurs when the voltage on the RESET pin goes below $0.3 \times V_{DD}$ for at least 100 nsec before rising above $0.7 \times V_{DD}$ as shown in [Figure 7](#).

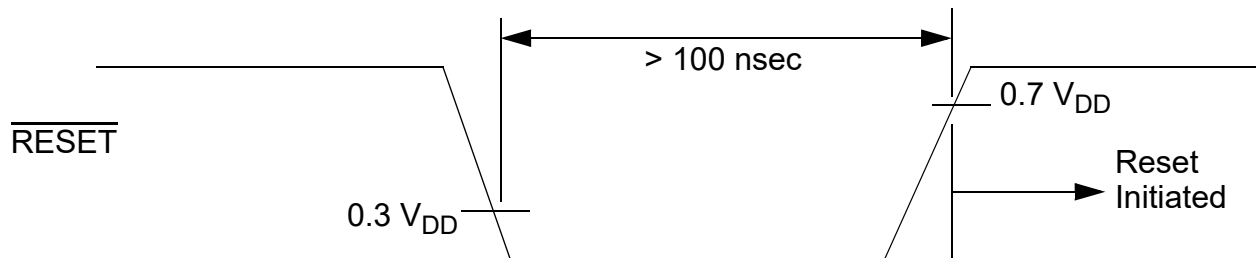

Figure 7. RESET Pin Timing

2.3.12 PTB[1:0] Pins

The PTB[1:0] pins are general purpose I/O pins. These two pins can be configured as nominal bidirectional I/O pins with programmable pullup. User software must configure the general purpose I/O pins so that they do not result in “floating” inputs as described in [Section 6.1](#)

3 Modes of Operation

The operating modes of the FXTH870x6 are described in this section. Entry into each mode, exit from each mode, and functionality while in each of the modes are described.

3.1 Features

- ACTIVE BACKGROUND DEBUG mode for code development
- STOP modes:
 - System clocks stopped
 - STOP1: Power down of most internal circuits, including RAM, for maximum power savings; voltage regulator in standby
 - STOP4: All internal circuits powered and full voltage regulation maintained for fastest recovery

3.2 RUN Mode

This is the normal operating mode for the FXTH870x6. This mode is selected when the BKGD/PTA4 pin is high at the rising edge of reset. In this mode, the CPU executes code from internal memory following a reset with execution beginning at address specified by the reset pseudo-vector (\$DFFE and \$DFFF).

3.3 WAIT Mode

The WAIT mode is also present like other members of the NXP S08 family members; but is not normally used by the FXTH870x6 firmware or typical TPMS applications.

3.4 ACTIVE BACKGROUND Mode

The ACTIVE BACKGROUND mode functions are managed through the BACKGROUND DEBUG controller (BDC) in the HCS08 core. The BDC provides the means for analyzing MCU operation during software development.

ACTIVE BACKGROUND mode is entered in any of four ways:

- When the BKGD/PTA4 pin is low at the rising edge of a power up reset
- When a BACKGROUND command is received through the BKGD/PTA4 pin
- When a BGND instruction is executed by the CPU
- When encountering a BDC breakpoint

Once in ACTIVE BACKGROUND mode, the CPU is held in a suspended state waiting for serial BACKGROUND commands rather than executing instructions from the user's application program. Background commands are of two types:

- Non-intrusive commands, defined as commands that can be issued while the user program is running. Non-intrusive commands can be issued through the BKGD/PTA4 pin while the MCU is in RUN mode; non-intrusive commands can also be executed when the MCU is in the ACTIVE BACKGROUND mode. Non-intrusive commands include:
 - Memory access commands
 - Memory-access-with-status commands
 - BDC register access commands
 - The BACKGROUND command
- ACTIVE BACKGROUND commands, which can only be executed while the MCU is in ACTIVE BACKGROUND mode. ACTIVE BACKGROUND commands include commands to:
 - Read or write CPU registers
 - Trace one user program instruction at a time
 - Leave ACTIVE BACKGROUND mode to return to the user's application program (GO)

The ACTIVE BACKGROUND mode is used to program a bootloader or user application program into the FLASH program memory before the MCU is operated in RUN mode for the first time. When the FXTH870x6 is shipped from the NXP factory, the FLASH program memory is erased by default (unless specifically requested otherwise) so there is no program that could be executed in RUN mode until the FLASH memory is initially programmed.

The ACTIVE BACKGROUND mode can also be used to erase and reprogram the FLASH memory after it has been previously programmed.

3.5 STOP Modes

One of two stop modes are entered upon execution of a STOP instruction when the STOPE bit in the system option register is set. In all STOP modes, all internal clocks are halted except for the low frequency 1 kHz oscillator (LFO) which runs continuously whenever power is applied to the V_{DD} and V_{SS} pins. If the STOPE bit is not set when the CPU executes a STOP instruction, the MCU will not enter any of the STOP modes and an illegal opcode reset is forced. The STOP modes are selected by setting the appropriate bits in SPMSC2. Table 1 summarizes the behavior of the MCU in each of the STOP1 and STOP4 modes. The STOP2 mode found in other NXP S08 family members is not available; but the STOP3 mode is present like other members of the NXP S08 family members.

3.5.1 STOP1 Mode

The STOP1 mode provides the lowest possible standby power consumption by causing the internal circuitry of the MCU to be powered down.

When the MCU is in STOP1 mode, all internal circuits that are powered from the voltage regulator are turned off. The voltage regulator is in a low-power standby state. STOP1 is exited by asserting either a reset or an interrupt function to the MCU.

Entering STOP1 mode automatically asserts LVD. STOP1 cannot be exited until the V_{DD} is greater than V_{LVDH} or $V_{LV/DL}$ rising (V_{DD} must rise above the LVI re-arm voltage).

Upon wakeup from STOP1 mode, the MCU will start up as from a power-on reset (POR) by taking the reset vector.

NOTE

If there are any pending interrupts that have yet to be serviced then the device will not go into the STOP1 mode. Be certain that all interrupt flags have been cleared before entry to STOP1 mode.

3.5.2 STOP4 LVD Enabled in STOP Mode

The LVD system is capable of generating either an interrupt or a reset when the supply voltage drops below the LVD voltage. If the LVD is enabled by setting the LVDE and the LVDSE bits in SPMSC1 when the CPU executes a STOP instruction, then the voltage regulator remains active during STOP mode. If the user attempts to enter the STOP1 with the LVD enabled in STOP ($LVDSE = 1$), the MCU will enter STOP4 instead.

Table 1. STOP Mode Behavior

Mode	STOP1	STOP4
LFO Oscillator, PWU	Always On & Clocking	
Real-Time Interrupt (RTI) ⁽¹⁾	Always On if using LFO as Clock	
MFO Oscillator ⁽²⁾	Optionally On	Optionally On
HFO Oscillator	Off	Off
CPU	Off	Standby
RAM	Off	Standby
Parameter Registers	On	On
FLASH	Off	Standby
TPM1 2-Chan Timer/PWM	Off	Off
Digital I/O	Disabled	Standby
Sensor Measurement Interface (SMI)	Off	Optionally On
Pressure P-cell	Off	Optionally On
Optional Acceleration g-cell	Off	Optionally On
Temperature Sensor (in ADC10)	Off	Optionally On ⁽³⁾
Normal Temperature Restart	Optionally On	Optionally On
Voltage Reference (in ADC10)	Off	Optionally On ⁽³⁾
LFR Detector ⁽⁴⁾	Periodically On	Periodically On
LFR Decoder	Optionally On	Optionally On
RF Controller, Data Buffer, Encoder	Optionally On	Optionally On
RF Transmitter ⁽⁵⁾	Optionally On	Optionally On
ADC10	Off	Optionally On ⁽³⁾

Table 1. STOP Mode Behavior (continued)

Mode	STOP1	STOP4
Regulator	Off	On
I/O Pins	Hi-Z	States Held
Wakeup Methods	Interrupts, resets	Interrupts, resets

1. RTI can be used in STOP1 or STOP4 if the clock selected is the LFO. To use the HFO as the clock the MCU must be in the RUN mode.
2. MFO oscillator started if the LFR detectors are periodically sampled, the LFR detectors detect an input signal; a pressure or acceleration reading is in progress or the RF state machine is sending data.
3. Requires internal ADC10 clock to be enabled.
4. Period of sampling set by MCU.
5. RF data buffer may be set up to run while the CPU is in the STOP modes.

Specific to the tire pressure monitoring application the parameter registers and the LFO with wakeup timer are powered up at all times whenever voltage is applied to the supply pins. The LFR detector and MFO may be periodically powered up by the LFR decoder.

3.5.3 Active BDM Enabled in STOP Mode

Entry into the ACTIVE BACKGROUND DEBUG mode from RUN mode is enabled if the ENBDM bit in BDCSCR is set. The BDCSCR register is not memory mapped so it can only be accessed through the BDM interface by use of the BDM commands READ_STATUS and WRITE_CONTROL. If ENBDM is set when the CPU executes a STOP instruction, the system clocks to the BACKGROUND DEBUG logic remain active when the MCU enters STOP mode so BACKGROUND DEBUG communication is still possible. In addition, the voltage regulator does not enter its low-power standby state but maintains full internal regulation. If the user attempts to enter the STOP1 with ENDBM set, the MCU will instead enter this mode which is STOP4 with system clocks running.

Most BACKGROUND commands are not available in STOP mode. The memory-access-with-status commands do not allow memory access, but they report an error indicating that the MCU is in STOP mode. The BACKGROUND command can be used to wake the MCU from stop and enter ACTIVE BACKGROUND mode if the ENDBM bit is set. Once in BACKGROUND DEBUG mode, all BACKGROUND commands are available.

3.5.4 MCU On-Chip Peripheral Modules in STOP Modes

When the MCU enters any STOP mode, system clocks to the internal peripheral modules except the wakeup timer and LFR detectors/decoder are stopped. Even in the exception case (ENDBM = 1), where clocks are kept alive to the BACKGROUND debug logic, clocks to the peripheral systems are halted to reduce power consumption.

I/O Pins

If the MCU is configured to go into STOP1 mode, the I/O pins are forced to their default reset state (Hi-Z) upon entry into stop. This means that the I/O input and output buffers are turned off and the pullup is disconnected.

Memory

All module interface registers will be reset upon wakeup from STOP1 and the contents of RAM are not preserved. The MCU must be initialized as upon reset. The contents of the FLASH memory are non-volatile and are preserved in any of the STOP modes.

Parameter Registers

The 64 bytes of parameter registers are kept active in all modes of operation as long as power is applied to the supply pins. The contents of the parameter registers behave like RAM and are unaffected by any reset.

LFO

The LFO remains active regardless of any mode of operation.

MFO

The medium frequency oscillator (MFO) will remain powered up when the MCU enters the STOP mode only when the SMI has been initiated to make a pressure or acceleration measurement; or when the RF transmitter's state machine is processing data.

HFO

The HFO is halted in all STOP modes.

PWU

The PWU remains active regardless of any mode of operation.

ADC10

The internal asynchronous ADC10 clock is always used as the conversion clock. The ADC10 can continue operation during STOP4 mode. Conversions can be initiated while the MCU is in the STOP4 mode. All ADC10 module registers contain their reset values following exit from STOP1 mode.

LFR

When the MCU enters STOP mode the detectors in the LFR will remain powered up depending on the states of the bits selecting the periodic sampling. Refer to [Section 12](#) for more details.

Bandgap Reference

The bandgap reference is enabled whenever the sensor measurement interface requires sensor or voltage measurements.

TPM1

When the MCU enters STOP mode, the clock to the TPM1 module stops and the module halts operation. If the MCU is configured to go into STOP1 mode, the TPM1 module will be reset upon wakeup from STOP and must be re-initialized.

Voltage Regulator

The voltage regulator enters a low-power standby state when the MCU enters any of the STOP modes except STOP4 (LVDSE = 1 or ENBDM = 1).

Temperature Sensor

The temperature sensor is powered up on command from the MCU.

Temperature Restart

When the MCU enters a STOP mode the temperature restart will remain powered up if the TRE bit is set. If the temperature restart level is reached the MCU will restart from the reset vector.

3.5.5 RFM Module in STOP Modes

The RFM's external crystal oscillator (XCO), bit rate generator, PLL, VCO, RF data buffer, data encoder, and RF output stage will remain powered up in STOP modes during a transmission, or if the SEND bit has been set and DIRECT mode has been enabled.

RF Output

When the RFM finishes a transmission sequence the external crystal oscillator (XCO), bit rate generator, PLL, VCO, RF data buffer, data encoder, and RF output stage will remain powered up if the SEND bit is set.

3.5.6 P-cell in STOP Modes

The P-cell is powered up only during a measurement if scheduled by the sensor measurement interface. Otherwise it is powered down.

3.5.7 Optional g-Cell in STOP Modes

The g-cell is powered up only during a measurement if scheduled by the sensor measurement interface. Otherwise it is powered down.

4 Memory

The overall memory map of the FXTH870x6 resides on the MCU.

4.1 MCU Memory Map

As shown in [Figure 8](#), MCU on-chip memory in the FXTH870x6 consists of parameter registers, RAM, FLASH program memory for nonvolatile data storage, and I/O and control/status registers. The registers are divided into four groups:

- Direct-page registers (\$0000 through \$004F)
- Parameter registers (\$0050 through \$008F)
- RAM (\$0090 through \$028F)
- High-page registers (\$1800 through \$182B)

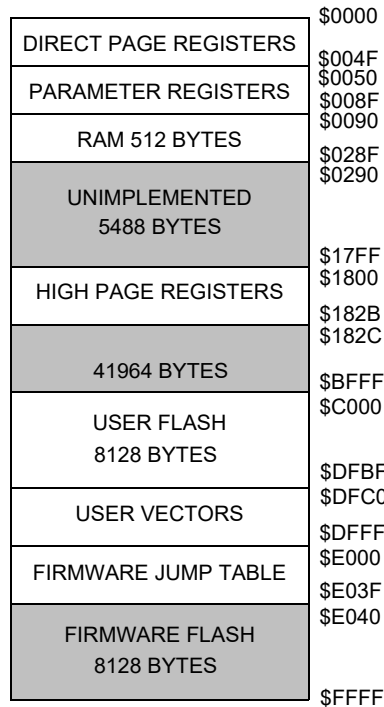

Figure 8. FXTH870x6 MCU Memory Map

The total programmable FLASH memory map is 16K, but the upper 8K is used for firmware and test software. Upon power up the firmware will initialize the device and redirect all vectors to the user area from \$DFC0 through \$DFFF. Any calls to the firmware subroutines are accessed through a jump table starting at location \$E000 (see [Section 14](#)).

4.2 Reset and Interrupt Vectors

[Table 2](#) shows address assignments for jump table to the reset and interrupt vectors. The vector names shown in this table are the labels used in the equate file provided by NXP in the CodeWarrior project file.

Table 2. Vector Summary

User Vector Addr	Vector Name	Module Source
\$DFE0:DFE1	Vkbi	KBI
\$DFE2:DFE3		Reserved
\$DFE4:DFE5		Reserved
\$DFE6:DFE7	Vrti	Sys Ctrl - RTI
\$DFE8:DFE9	Vlfrcvr	LFR
\$DFEA:DFEB	Vadc1	ADC10
\$DFEC:DFED	Vrf	RFM

Table 2. Vector Summary (continued)

User Vector Addr	Vector Name	Module Source
\$DFEE:DDEF	Vsm	SMI
\$DFF0:DFF1	Vtpm1ovf	TPM1
\$DFF2:DFF3	Vtpm1ch1	TPM1
\$DFF4:DFF5	Vtpm1ch0	TPM1
\$DFF6:DFF7	Vwuktmr	PWUJ
\$DFF8:DFF9	Vlvd	Sys Ctrl - LVD
\$DFFA:DFFB	Reserved	
\$DFFC:DFFD	Vswi	SWI opcode
\$DFFE:DFFF	Vreset	Sys Ctrl - POR, PRF, COP, LVD Temp Restart, Illegal opcode or address

4.3 MCU Register Addresses and Bit Assignments

The registers in the FXTH870x6 are divided into these four groups:

- Direct-page registers are located in the first 80 locations in the memory map; these are accessible with efficient direct addressing mode instructions.
- The parameter registers begin at address \$0050; these are also accessible with efficient direct addressing mode instructions.
- High-page registers are used less often, so they are located above \$1800 in the memory map. This leaves more room in the direct page for more frequently used registers and variables.
- The nonvolatile register area consists of a block of 16 locations in FLASH memory at \$FFB0:FFBF. Nonvolatile register locations include:
 - Three values that are loaded into working registers at reset
 - An 8-byte back door comparison key that optionally allows the user to gain controlled access to secure memory.

Because the nonvolatile register locations are FLASH memory, they must be erased and programmed like other FLASH memory locations.

Direct page registers are located within the first 256 locations in the memory map, so they are accessible with efficient direct addressing mode instructions, which requires only the lower byte of the address. Bit manipulation instructions can be used to access any bit in any direct-page register. Table 3 is a summary of all user-accessible direct-page registers and control bits. Those related to the TPMS application and modules are described in detail in this specification.

The register names in column two of the following tables are shown in bold to set them apart from the bit names to the right. Cells that are not associated with named bits are shaded. A shaded cell with a 0 indicates this unused bit always reads as a 0. Shaded cells with dashes indicate unused or reserved bit locations that could read as 1s or 0s.

Table 3. MCU Direct Page Register Summary

Address	Register Name	Bit 7	6	5	4	3	2	1	Bit 0
\$0000	PTAD				PTAD[4:0]				
\$0001	PTAPE				PTAPE[3:0]				
\$0002	Reserved								
\$0003	PTADD				PTADD[3:0]				
\$0004	PTBD						PTBD[1:0]		
\$0005	PTBPE						PTBPE[1:0]		
\$0006	Reserved								
\$0007	PTBDD						PTBDD[1:0]		
\$0008	Reserved								
\$0009	Reserved								
\$000A	Reserved								
\$000B	Reserved								
\$000C	KBISC	0	0	0	0	KBF	KBACK	KBIE	KBIMOD

FXTH870x6

Table 3. MCU Direct Page Register Summary (continued)

Address	Register Name	Bit 7	6	5	4	3	2	1	Bit 0
\$000D	KBIPE					KBIPE[3:0]			
\$000E	KBIES					KBEDG[3:0]			
\$000F	Reserved								
\$0010	TPM1SC	TOF	TOIE	CPWMS	CLKSB	CLKSA	PS2	PS1	PS0
\$0011	TPM1CNTH	Bit [15:8]							
\$0012	TPM1CNTL	Bit [7:0]							
\$0013	TPM1MODH	Bit [15:8]							
\$0014	TPM1MODL	Bit [7:0]							
\$0015	TPM1C0SC	CH0F	CH0IE	MS0B	MS0A	ELS0B	ELS0A	0	0
\$0016	TPM1C0VH	Bit [15:8]							
\$0017	TPM1C0VL	Bit [7:0]							
\$0018	TPM1C1SC	CH1F	CH1IE	MS1B	MS1A	ELS1B	ELS1A	0	0
\$0019	TPM1C1VH	Bit [15:8]							
\$001A	TPM1C1VL	Bit [7:0]							
\$001B	Reserved								
\$001C	PWUDIV			WDIV[5:0]					
\$001D	PWUCS0	WUF	WUFAK	WUT[5:0]					
\$001E	PWUCS1	PRF	PRFAK	PRST[5:0]					
\$001F	PWUS	PSEL	0	CSTAT[5:0]					
\$0020-27	LFR Registers	LFR Registers, see Table 4 and Table 5							
\$0028	ADSC1	COCO	AIEN	ADCO	ADCH[4:0]				
\$0029	ADSC2	ADACT	ADTRG	ACFE	ADCFGT	0	0	0	0
\$002A	ADRH	0	0	0	0	ADR[11:8]			
\$002B	ADRL	ADR[7:0]							
\$002C	ADCVH	0	0	0	0	ADCV[11:8]			
\$002D	ADCVL	ADCV[7:0]							
\$002E	ADCFG	ADLPC	ADIV[1:0]		ADLSMP	MODE[1:0]		ADICLK[1:0]	
\$002F	ADPCTL1	ADPC[7:0]							
\$0030-4F	RFM Registers	RFM Registers, see Table 6 and Table 7							
\$0050-8F	Parameter Reg	PARAM[63:0]							

Note: Shaded bits are recommended to only be controlled by firmware or factory test.

Table 4. LFR Register Summary - LPAGE = 0

Address	Register Name	Bit 7	6	5	4	3	2	1	Bit 0	
\$0020	LFCTL1	LFEN	SRES	CARMOD	LPAGE	IDSEL[1:0]		SENS[1:0]		
\$0021	LFCTL2	LFSTM[3:0]				LFONTM[3:0]				
\$0022	LFCTL3	LFDO	TOGMOD	SYNC[1:0]		LFCDTM[3:0]				
\$0023	LFCTL4	LFDRIE	LFERIE	LFCDIE	LFIDIE	DECEN	VALEN	TIMOUT[1:0]		
\$0024	LFS	LFDRF	LFERF	LFCDF	LFIDF	LFOVF	LFEOMF	LPSM	LFIK	
\$0025	LFDATA	RXDATA[7:0]								
\$0026	LFIDL	ID[7:0]								
\$0027	LFIDH	ID[15:8]								

Table 5. LFR Register Summary - LPAGE = 1

Address	Register Name	Bit 7	6	5	4	3	2	1	Bit 0
\$0020	LFCTL1	LFEN	SRES	CARMOD	LPAGE	IDSEL[1:0]		SENS[1:0]	
\$0021	LFCTRL1					TRIMEE	AZSC[2:0]		
\$0022	LFCTRLD	AVFOF[1:0]		DEQS	AZDC[1:0]		ONMODE	CHK125[1:0]	
\$0023	LFCTRLC	AMPGAIN[1:0]		FINSEL[1:0]		AZEN	LOWQ[1:0]		DEQEN
\$0024	LFCTRLB	HYST[1:0]		LFFAF	LFCAF	LFPOL	LFCPTAZ[2:0]		
\$0025	LFCTRLA	TESTSEL[3:0]				LFCC[3:0]			
\$0026	Reserved								
\$0027	Reserved								

Note: Shaded bits are recommended to only be controlled by firmware or factory test.

Table 6. RFM Register Summary - RPAGE = 0

Address	Register Name	Bit 7	6	5	4	3	2	1	Bit 0	
\$0030	RFCR0	BPS[7:0]								
\$0031	RFCR1	FRM[7:0]								
\$0032	RFCR2	SEND	RPAGE	EOM	PWR[4:0]					
\$0033	RFCR3	DATA	IFPD	ISPC	IFID	FNUM[3:0]				
\$0034	RFCR4	RFBT[7:0]								
\$0035	RFCR5	BOOST	LFSR[6:0]							
\$0036	RFCR6	VCO_GAIN[1:0]		RFFT[5:0]						
\$0037	RFCR7	RFIF	RFEF	RFVF	RFAK	RFIEN	RFLVDEN	RCTS	RFMRST	
\$0038	PLLCR0	AFREQ[12:5]								
\$0039	PLLCR1	AFREQ[4:0]					POL	CODE[1:0]		
\$003A	PLLCR2	BFREQ[12:5]								
\$003B	PLLCR3	BFREQ[4:0]					CF	MOD	CKREF	
\$003C	RFD0	RFD[7:0]								
\$003D	RFD1	RFD[15:8]								
\$003E	RFD2	RFD[23:16]								
\$003F	RFD3	RFD[31:24]								
\$0040	RFD4	RFD[39:32]								
\$0041	RFD5	RFD[47:40]								
\$0042	RFD6	RFD[55:48]								
\$0043	RFD7	RFD[63:56]								
\$0044	RFD8	RFD[71:64]								
\$0045	RFD9	RFD[79:72]								
\$0046	RFD10	RFD[87:80]								
\$0047	RFD11	RFD[95:88]								
\$0048	RFD12	RFD[103:96]								
\$0049	RFD13	RFD[111:104]								
\$004A	RFD14	RFD[119:112]								
\$004B	RFD15	RFD[127:120]								
\$004C	Reserved									
\$004D	Reserved									
\$004E	Reserved									
\$004F	Reserved									

Note: Shaded bits are recommended to only be controlled by firmware or factory test.

Table 7. RFM Register Summary - RPAGE = 1

Address	Register Name	Bit 7	6	5	4	3	2	1	Bit 0
\$0030	RFCR0	BPS[7:0]							
\$0031	RFCR1	FRM[7:0]							
\$0032	RFCR2	SEND	RPAGE	EOM	PWR[4:0]				
\$0033	RFCR3	DATA	IFPD	ISPC	IFID	FNUM[3:0]			
\$0034	RFCR4	RFBT[7:0]							
\$0035	RFCR5	BOOST	LFSR[6:0]						
\$0036	RFCR6	VCO_GAIN[1:0]		RFFT[5:0]					
\$0037	RFCR7	RFIF	RFEF	RFVF	RFAK	RFIEN	RFLVDEN	RCTS	RFMRST
\$0038	EPR	—/VCD3	PLL_LPF_[2:0]/VCD[2:0]					PA_SLOPE	VCD_EN
\$0039	Reserved								
\$003A	Reserved								
\$003B	Reserved								
\$003C	RFD0	RFD[135:128]							
\$003D	RFD1	RFD[143:136]							
\$003E	RFD2	RFD[151:144]							
\$003F	RFD3	RFD[159:152]							
\$0040	RFD4	RFD[167:160]							
\$0041	RFD5	RFD[175:168]							
\$0042	RFD6	RFD[183:176]							
\$0043	RFD7	RFD[191:184]							
\$0044	RFD8	RFD[199:192]							
\$0045	RFD9	RFD[207:200]							
\$0046	RFD10	RFD[215:208]							
\$0047	RFD11	RFD[223:216]							
\$0048	RFD12	RFD[231:224]							
\$0049	RFD13	RFD[239:232]							
\$004A	RFD14	RFD[247:240]							
\$004B	RFD15	RFD[255:248]							
\$004C	Reserved								
\$004D	Reserved								
\$004E	Reserved								
\$004F	Reserved								

Note: Shaded bits are recommended to only be controlled by firmware or factory test.

4.4 High Address Registers

High-page registers are used much less often, so they are located above \$1800 in the memory map. This leaves more room in the direct page for more frequently used registers and variables. The registers control system level features as given in [Table 8](#).

Table 8. MCU High Address Register Summary

Address	Register Name	Bit 7	6	5	4	3	2	1	Bit 0
\$1800	SRS	POR	PIN	COP	ILOP	ILAD	PWU	LVD	0
\$1801	SBDFR	0	0	0	0	0	0	0	BDFR
\$1802	SIMOPT1	COPE	COPCLKS	STOPE	RFEN	TRE	TRH	BKGDPE	1
\$1803	SIMOPT2	0	COPT[2:0]			LFOSEL	TCLKDIV	BUSCLKS[1:0]	
\$1804	Reserved								
\$1805	Reserved								
\$1806	SDIDH	REV[3:0]				ID[11:8]			
\$1807	SDIDL	ID[7:0]							
\$1808	SRTISC	RTIF	RTIACK	RTICLKS	RTIE	0	RTIS[2:0]		
\$1809	SPMSC1	LVDF	LVDACK	LVDIE	LVDRE	LVDSE	LVDE	0	BGBE
\$180A	SPMSC2	0	0	0	PDF	0	PPDACK	PDC	0
\$180B	Reserved								
\$180C	SPMSC3	LVWF	LVWACK	LVDV	LVWV	0	0	0	0
\$180D	SIMSES			KBF	IRQF	TRF	PWUF	LFF	RFF
\$180E	SOTRM	SOTRM[7:0]							
\$180F	SIMTST		TRH[2:0]						TRO
\$1810-1F	Reserved								
\$1820	FCDIV	DIVLD	PRDIV8	DIV[5:0]					
\$1821	FOPT	KEYEN	FNORED	0	0	0	0	SEC0[1:0]	
\$1822	Reserved								
\$1823	FCNFG	0	0	KEYACC	0	0	0	0	0
\$1824	FPROT	FPS[7:1]							FPDIS
\$1825	FSTAT	FCBEF	FCCF	FPVIOL	FACCERR	0	FBLANK	0	0
\$1826	FCMD	FERASE	FCMD[6:0]						
\$1827-3F	Reserved								

Note: Reserved bits shown as 0 must always be written to 0.

Reserved bits shown as 1 must always be written to 1.

Shaded bits are recommended to only be controlled by firmware or factory test.

4.5 MCU Parameter Registers

The 64 bytes of parameter registers are located at addresses \$0050 through \$008F. These registers are powered up at all times and may be used to store temporary or history data during the times that the MCU is in any of the STOP modes. The parameter register at \$008F is used by the firmware for interrupt flags.

4.6 MCU RAM

The FXTH870x6 includes static RAM. The locations in RAM below \$0100 can be accessed using the more efficient direct addressing mode, and any single bit in this area can be accessed with the bit-manipulation instructions (BCLR, BSET, BRCLR, and BRSET). Locating the most frequently accessed program variables in this area of RAM is preferred.

The RAM retains data when the MCU is in low-power WAIT, STOP3 or STOP4 modes. At power-on or after wakeup from STOP1, the contents of RAM are not initialized. RAM data is unaffected by any reset provided that the supply voltage does not drop below the minimum value for RAM retention (VRAM).

When security is enabled, the RAM is considered a secure memory resource and is not accessible through BDM or through code executing from non-secure memory. See [Section 4.8](#) for a detailed description of the security feature.

None of the RAM locations are used directly by the firmware provided by NXP. The firmware routines utilize RAM only through stack operations; and the user needs to be aware of stack depth required by each routine as described in the CodeWarrior project files supplied by NXP.

4.7 FLASH

The FLASH memory is intended primarily for program storage. The operating program can be loaded into the FLASH memory after final assembly of the application product using the single-wire BACKGROUND DEBUG interface. Because no special voltages are needed for FLASH erase and programming operations, in-application programming is also possible through other software-controlled communication paths. For a more detailed discussion of in-circuit and in-application programming, refer to the *HCS08 Family Reference Manual, Volume I*, NXP document order number HCS08RMV1/D.

4.7.1 Features

Features of the FLASH memory include:

- User Program FLASH Size — 8192 bytes (16 pages of 512 bytes each)
- Single power supply program and erase
- Command interface for fast program and erase operation
- Up to 100,000 program/erase cycles at typical voltage and temperature
- Flexible block protection
- Security feature for FLASH and RAM
- Auto power-down for low-frequency read accesses

4.7.2 Program and Erase Times

Before any program or erase command can be accepted, the FLASH clock divider register (FCDIV) must be written to set the internal clock for the FLASH module to a frequency (f_{FCLK}) between 150 kHz and 200 kHz. This register can be written only once, so normally this write is performed during reset initialization. FCDIV cannot be written if the access error flag, FACCERR in FSTAT, is set. The user must ensure that FACCERR is not set before writing to the FCDIV register. One period of the resulting clock ($1/f_{FCLK}$) is used by the command processor to time program and erase pulses. An integer number of these timing pulses are used by the command processor to complete a program or erase command.

Table 9 shows program and erase times. The bus clock frequency and FCDIV determine the frequency of FCLK (f_{FCLK}). The time for one cycle of FCLK is $t_{FCLK} = 1/f_{FCLK}$. The times are shown as a number of cycles of FCLK and as an absolute time for the case where $t_{FCLK} = 5 \mu\text{s}$. Program and erase times shown include overhead for the command state machine and enabling and disabling of program and erase voltages.

Table 9. Program and Erase Times

Parameter	Cycles of FCLK	Time if FCLK = 200 kHz
Byte program	9	45 μs
Byte program (burst)	4	20 μs ⁽¹⁾
Page erase	4000	20 ms
Mass erase	20,000	100 ms

1. Excluding start/end overhead

4.7.3 Program and Erase Command Execution

The steps for executing any of the commands are listed below. The FCDIV register must be initialized and any error flags cleared before beginning command execution. The command execution steps are:

1. Write a data value to an address in the FLASH array. The address and data information from this write is latched into the FLASH interface. This write is a required first step in any command sequence. For erase and blank check commands, the value of the data is not important. For page erase commands, the address may be any address in the 512-byte page of FLASH to be erased. For mass erase and blank check commands, the address can be any address in the FLASH memory. Whole pages of 512 bytes are the smallest block of FLASH that may be erased. Do not program any byte in the FLASH more than once after a successful erase operation. Reprogramming bits to a byte which is already programmed is not allowed without first erasing the page in which the byte resides or mass erasing the entire FLASH memory. Programming without first erasing may disturb data stored in the FLASH.

2. Write the command code for the desired command to FCMD. The five valid commands are blank check (0x05), byte program (0x20), burst program (0x25), page erase (0x40), and mass erase (0x41). The command code is latched into the command buffer.
3. Write a 1 to the FCBEF bit in FSTAT to clear FCBEF and launch the command (including its address and data information).

A partial command sequence can be aborted manually by writing a 0 to FCBEF any time after the write to the memory array and before writing the 1 that clears FCBEF and launches the complete command. Aborting a command in this way sets the FACCERR access error flag which must be cleared before starting a new command.

A strictly monitored procedure must be obeyed or the command will not be accepted. This minimizes the possibility of any unintended changes to the FLASH memory contents. The command complete flag (FCCF) indicates when a command is complete. The command sequence must be completed by clearing FCBEF to launch the command. [Figure 9](#) is a flowchart for executing all of the commands except for burst programming. The FCDIV register must be initialized before using any FLASH commands. This must be done only once following a reset.

4.7.4 Burst Program Execution

The burst program command is used to program sequential bytes of data in less time than would be required using the standard program command. This is possible because the high voltage to the FLASH array does not need to be disabled between program operations. Ordinarily, when a program or erase command is issued, an internal charge pump associated with the FLASH memory must be enabled to supply high voltage to the array. Upon completion of the command, the charge pump is turned off. When a burst program command is issued, the charge pump is enabled and then remains enabled after completion of the burst program operation if these two conditions are met:

- The next burst program command has been queued before the current program operation has completed.
- The next sequential address selects a byte on the same physical row as the current byte being programmed. A row of FLASH memory consists of 64 bytes. A byte within a row is selected by addresses A5 through A0. A new row begins when addresses A5 through A0 are all zero.

The first byte of a series of sequential bytes being programmed in burst mode will take the same amount of time to program as a byte programmed in standard mode. Subsequent bytes will program in the burst program time provided that the conditions above are met. In the case the next sequential address is the beginning of a new row, the program time for that byte will be the standard time instead of the burst time. This is because the high voltage to the array must be disabled and then enabled again. If a new burst command has not been queued before the current command completes, then the charge pump will be disabled and high voltage removed from the array.

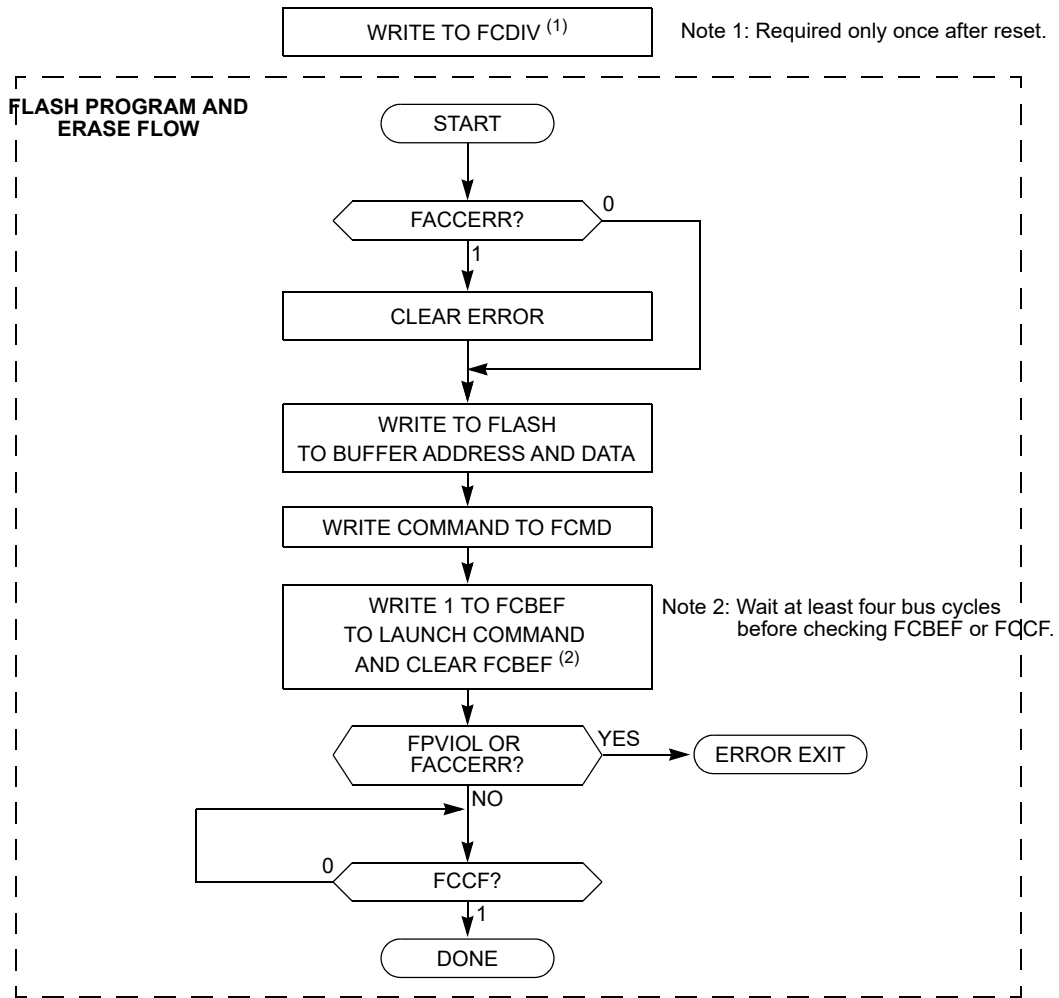

Figure 9. FLASH Program and Erase Flowchart

Programming time for the FLASH through the BDM function is dependent on the specific external BDM interface tool and software being used. Consult tool vendor for programming times.

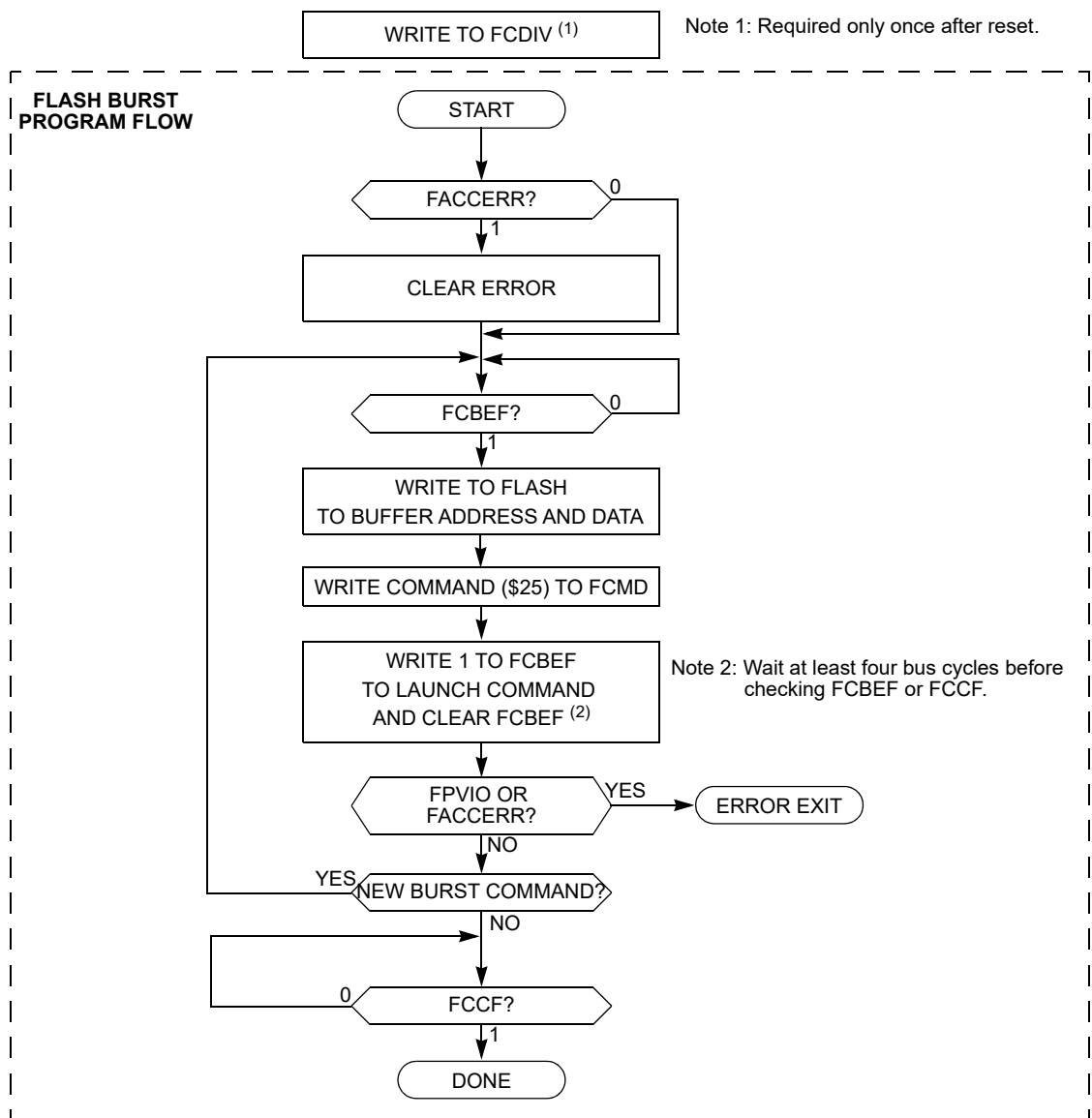

Figure 10. FLASH Burst Program Flowchart

4.7.5 Access Errors

An access error occurs whenever the command execution protocol is violated.

Any of the following specific actions will cause the access error flag (FACCERR) in FSTAT to be set. FACCERR must be cleared by writing a 1 to FACCERR in FSTAT before any command can be processed.

- Writing to a FLASH address before the internal FLASH clock frequency has been set by writing to the FCDIV register
- Writing to a FLASH address while FCBEF is not set (A new command cannot be started until the command buffer is empty.)
- Writing a second time to a FLASH address before launching the previous command (There is only one write to FLASH for every command.)
- Writing a second time to FCMD before launching the previous command (There is only one write to FCMD for every command.)
- Writing to any FLASH control register other than FCMD after writing to a FLASH address
- Writing any command code other than the five allowed codes (0x05, 0x20, 0x25, 0x40, or 0x41) to FCMD
- Accessing (read or write) any FLASH control register other than the write to FSTAT (to clear FCBEF and launch the command) after writing the command to FCMD.
- The MCU enters STOP mode while a program or erase command is in progress (The command is aborted.)

- Writing the byte program, burst program, or page erase command code (0x20, 0x25, or 0x40) with a BACKGROUND DEBUG command while the MCU is secured (the BACKGROUND DEBUG controller can only do blank check and mass erase commands when the MCU is secure.)
- Writing 0 to FCBEF to cancel a partial command.

4.7.6 FLASH Block Protection

The block protection feature prevents the protected region of FLASH from program or erase changes. Block protection is controlled through the FLASH Protection Register (FPROT). When enabled, block protection begins at any 512-byte boundary below the last address of FLASH, 0xFFFF. (see [Section 4.9.4](#)).

After exit from reset, FPROT is loaded with the contents of the NVPROT location which is in the nonvolatile register block of the FLASH memory. FPROT cannot be changed directly from application software so a runaway program cannot alter the block protection settings. Because NVPROT is within the last 512 bytes of FLASH, if any amount of memory is protected, NVPROT is itself protected and cannot be altered (intentionally or unintentionally) by the application software. FPROT can be written through BACKGROUND DEBUG commands which allows a way to erase and reprogram a protected FLASH memory.

The block protection mechanism is illustrated below. The FPS bits are used as the upper bits of the last address of unprotected memory. This address is formed by concatenating FPS7:FPS1 with logic 1 bits as shown. For example, in order to protect the last 8192 bytes of memory (addresses 0xE000 through 0xFFFF), the FPS bits must be set to 1101 111 which results in the value 0xDFFF as the last address of unprotected memory. In addition to programming the FPS bits to the appropriate value, FPDIS (bit 0 of NVPROT) must be programmed to logic 0 to enable block protection. Therefore the value 0xDE must be programmed into NVPROT to protect addresses 0xE000 through 0xFFFF.

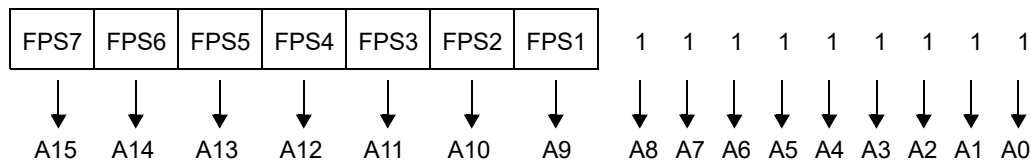

Figure 11. Block Protection Mechanism

One use for block protection is to block protect an area of FLASH memory for a bootloader program. This bootloader program then can be used to erase the rest of the FLASH memory and reprogram it. Because the bootloader is protected, it remains intact even if MCU power is lost in the middle of an erase and reprogram operation.

4.7.7 Vector Redirection

NOTE

Not recommended for TPMS applications where NXP firmware has been included in the final image.

Whenever any block protection is enabled, the reset and interrupt vectors will be protected. Vector redirection allows users to modify interrupt vector information without unprotecting bootloader and reset vector space. Vector redirection is enabled by programming the FNORED bit in the NVOPT register located at address 0xFFBF to zero. For redirection to occur, at least some portion but not all of the FLASH memory must be block protected by programming the NVPROT register located at address 0xFFBD. All of the interrupt vectors (memory locations 0xFFC0–0xFFFD) are redirected, though the reset vector (0xFFFE:FFFF) is not.

For example, if 512 bytes of FLASH are protected, the protected address region is from 0xFE00 through 0xFFFF. The interrupt vectors (0xFFC0–0xFFFD) are redirected to the locations 0xFDC0–0xFDFD. Now, if an SPI interrupt is taken for instance, the values in the locations 0xFDE0:FDE1 are used for the vector instead of the values in the locations 0xFFE0:FFE1. This allows the user to reprogram the unprotected portion of the FLASH with new program code including new interrupt vector values while leaving the protected area, which includes the default vector locations, unchanged.

4.8 Security

The FXTH870x6 includes circuitry to prevent unauthorized access to the contents of FLASH and RAM memory. When security is engaged, FLASH and RAM are considered secure resources. Direct-page registers, high-page registers, and the BACKGROUND DEBUG controller are considered unsecured resources. Programs executing within secure memory have normal access to any MCU memory locations and resources. Attempts to access a secure memory location with a program executing from an unsecured memory space or through the BACKGROUND DEBUG interface are blocked (writes are ignored and reads return all 0s).

Security is engaged or disengaged based on the state of two nonvolatile register bits (SEC0[1:0]) in the FOPT register. During reset, the contents of the nonvolatile location NVOPT are copied from FLASH into the working FOPT register in high-page register space. A user engages security by programming the NVOPT location, which can be done at the same time the FLASH memory is programmed. The 1:0 state disengages security and the other three combinations engage security. Notice the erased state (1:1) makes the MCU secure. During development, whenever the FLASH is erased, it is good practice to immediately program the SEC00 bit to 0 in NVOPT so SEC[1:0] = 1:0. This would allow the MCU to remain unsecured after a subsequent reset.

The on-chip debug module cannot be enabled while the MCU is secure. The separate BACKGROUND DEBUG controller can still be used for background memory access commands, but the MCU cannot enter ACTIVE BACKGROUND mode except by holding BKGD/MS low at the rising edge of reset.

A user can choose to allow or disallow a security unlocking mechanism through an 8-byte backdoor security key. If the nonvolatile KEYEN bit in NVOPT/FOPT is 0, the backdoor key is disabled and there is no way to disengage security without completely erasing all FLASH locations. If KEYEN is 1, a secure user program can temporarily disengage security by:

1. Writing 1 to KEYACC in the FCNFG register. This makes the FLASH module interpret writes to the backdoor comparison key locations (NVBACKKEY through NVBACKKEY+7) as values to be compared against the key rather than as the first step in a FLASH program or erase command.
2. Writing the user-entered key values to the NVBACKKEY through NVBACKKEY+7 locations. These writes must be done in order starting with the value for NVBACKKEY and ending with NVBACKKEY+7. STHX must not be used for these writes because these writes cannot be done on adjacent bus cycles. User software normally would get the key codes from outside the MCU system through a communication interface such as a serial I/O.
3. Writing 0 to KEYACC in the FCNFG register. If the 8-byte key that was just written matches the key stored in the FLASH locations, SEC[1:0] are automatically changed to 1:0 and security will be disengaged until the next reset.

The security key can be written only from secure memory (either RAM or FLASH), so it cannot be entered through BACKGROUND commands without the cooperation of a secure user program.

The backdoor comparison key (NVBACKKEY through NVBACKKEY+7) is located in FLASH memory locations in the nonvolatile register space so users can program these locations exactly as they would program any other FLASH memory location. The nonvolatile registers are in the same 512-byte block of FLASH as the reset and interrupt vectors, so block protecting that space also block protects the backdoor comparison key. Block protects cannot be changed from user application programs, so if the vector space is block protected, the backdoor security key mechanism cannot permanently change the block protect, security settings, or the backdoor key.

Security can always be disengaged through the BACKGROUND DEBUG interface by taking these steps:

1. Disable any block protections by writing FPROT. FPROT can be written only with BACKGROUND DEBUG commands, not from application software.
2. Mass erase FLASH if necessary.
3. Blank check FLASH. Provided FLASH is completely erased, security is disengaged until the next reset.

To avoid returning to secure mode after the next reset, program NVOPT so SEC[1:0] = 1:0.

NOTE

Enabling the security feature disables NXP ability to perform failure analysis without first completely erasing all flash memory contents. If the security feature is implemented, customer shall be responsible for providing to NXP unsecured parts for any failure analysis to begin or supplying the entire contents of the device flash memory data as part of the return process, to allow NXP to erase and subsequently restore the device to its original condition.

4.9 FLASH Registers and Control Bits

The FLASH module has nine 8-bit registers in the high-page register space, three locations in the nonvolatile register space in FLASH memory which are copied into three corresponding high-page control registers at reset. There is also an 8-byte comparison key in FLASH memory. Refer to [Table 8](#) and [Table 9](#) for the absolute address assignments for all FLASH registers. This section refers to registers and control bits only by their names. A NXP provided equate or header file normally is used to translate these names into the appropriate absolute addresses.

4.9.1 FLASH Clock Divider Register (FCDIV)

Bit 7 of this register is a read-only status flag. Bits 6 through 0 can be read at any time but can be written only once. Before any erase or programming operations are possible, write to this register to set the frequency of the clock for the nonvolatile memory system within acceptable limits.

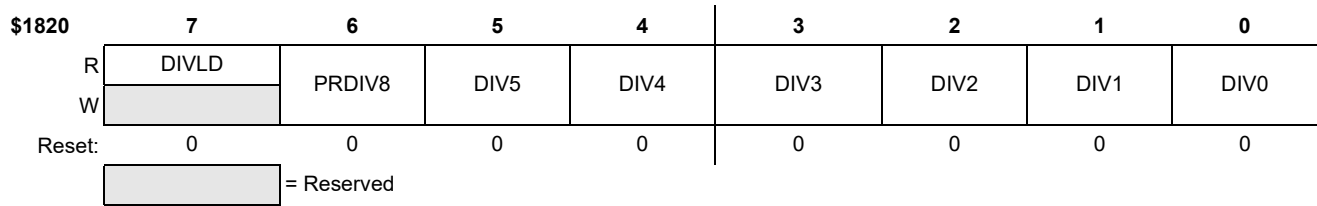

Figure 12. FLASH Clock Divider Register (FCDIV)

Table 10. FCDIV Register Field Descriptions

Field	Description
7 DIVLD	Divisor Loaded Status Flag — When set, this read-only status flag indicates that the FCDIV register has been written since reset. Reset clears this bit and the first write to this register causes this bit to become set regardless of the data written. 0 FCDIV has not been written since reset; erase and program operations disabled for FLASH 1 FCDIV has been written since reset; erase and program operations enabled for FLASH
6 PRDIV8	Prescale (Divide) FLASH Clock by 8 0 Clock input to the FLASH clock divider is the bus rate clock 1 Clock input to the FLASH clock divider is the bus rate clock divided by 8
5:0 DIV[5:0]	Divisor for FLASH Clock Divider — The FLASH clock divider divides the bus rate clock (or the bus rate clock divided by 8 if PRDIV8 = 1) by the value in the 6-bit DIV5:DIV0 field plus one. The resulting frequency of the internal FLASH clock must fall within the range of 200 kHz to 150 kHz for proper FLASH operations. Program/Erase timing pulses are one cycle of this internal FLASH clock which corresponds to a range of 5 μs to 6.7 μs. The automated programming logic uses an integer number of these pulses to complete an erase or program operation. <ul style="list-style-type: none"> if PRDIV8 = 0 — $f_{\text{FLK}} = f_{\text{Bus}} \div ([\text{DIV5:DIV0}] + 1)$ if PRDIV8 = 1 — $f_{\text{FLK}} = f_{\text{Bus}} \div (8 \times ([\text{DIV5:DIV0}] + 1))$ Table 11 shows the appropriate values for PRDIV8 and DIV5:DIV0 for selected bus frequencies.

Table 11. FLASH Clock Divider Settings

f_{Bus}	PRDIV8 (Binary)	DIV5:DIV0 (Decimal)	f_{FLK}	Program/Erase Timing Pulse (5 μs Min, 6.7 μs Max)
20 MHz	1	12	192.3 kHz	5.2 μs
10 MHz	0	49	200 kHz	5 μs
8 MHz	0	39	200 kHz	5 μs
4 MHz	0	19	200 kHz	5 μs
2 MHz	0	9	200 kHz	5 μs
1 MHz	0	4	200 kHz	5 μs
200 kHz	0	0	200 kHz	5 μs
150 kHz	0	0	150 kHz	6.7 μs

4.9.2 FLASH Options Register (FOPT and NVOPT)

During reset, the contents of the nonvolatile location NVOPT are copied from FLASH into FOPT. Bits 5 through 2 are not used and always read 0. This register may be read at any time, but writes have no meaning or effect. To change the value in this register, erase and reprogram the NVOPT location in FLASH memory as usual and then issue a new MCU reset.

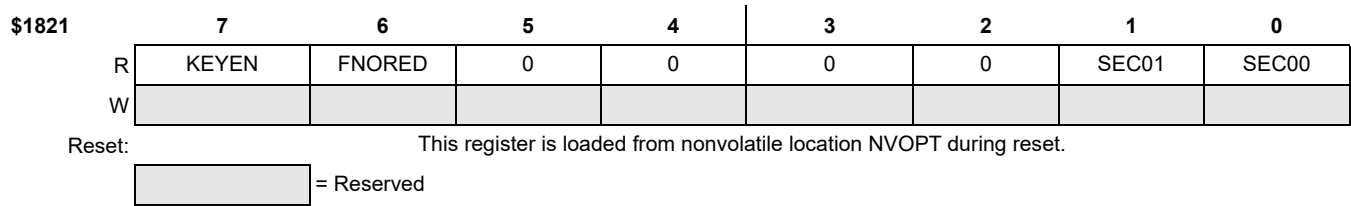

Figure 13. FLASH Options Register (FOPT)

Table 12. FOPT Register Field Descriptions

Field	Description
7 KEYEN	Backdoor Key Mechanism Enable — When this bit is 0, the backdoor key mechanism cannot be used to disengage security. The backdoor key mechanism is accessible only from user (secured) firmware. BDM commands cannot be used to write key comparison values that would unlock the backdoor key. For more detailed information about the backdoor key mechanism, refer to Section 4.8 . 0 No backdoor key access allowed 1 If user firmware writes an 8-byte value that matches the nonvolatile backdoor key (NVBACKKEY through NVBACKKEY+7 in that order), security is temporarily disengaged until the next MCU reset
6 FNORED	Vector Redirection Disable — When this bit is 1, then vector redirection is disabled. 0 Vector redirection enabled 1 Vector redirection disabled
1:0 SEC0[1:0]	Security State Code — This 2-bit field determines the security state of the MCU as shown in Table 13 . When the MCU is secure, the contents of RAM and FLASH memory cannot be accessed by instructions from any unsecured source including the BACKGROUND DEBUG interface. For more detailed information about security, refer to Section 4.8 . SEC01:SEC00 changes to 1:0 after successful backdoor key entry or a successful blank check of FLASH.

Table 13. Security States

SEC01:SEC00	Description
0:0	secure
0:1	secure
1:0	unsecured
1:1	secure

4.9.3 FLASH Configuration Register (FCNFG)

Bits 7 through 5 can be read or written at any time. Bits 4 through 0 always read 0 and cannot be written.

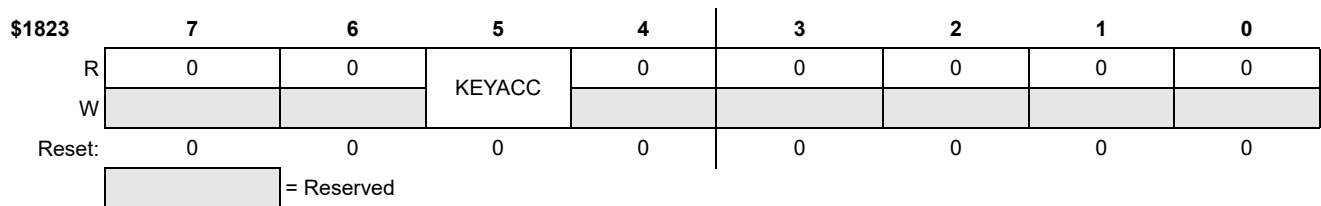

Figure 14. FLASH Configuration Register (FCNFG)

Table 14. FCNFG Register Field Descriptions

Field	Description
5 KEYACC	Enable Writing of Access Key — This bit enables writing of the backdoor comparison key. For more detailed information about the backdoor key mechanism, refer to Section 4.8 . 0 Writes to 0xFFB0–0xFFB7 are interpreted as the start of a FLASH programming or erase command 1 Writes to NVBACKKEY (0xFFB0–0xFFB7) are interpreted as comparison key writes

4.9.4 FLASH Protection Register (FPROT and NVPROT)

During reset, the contents of the nonvolatile location NVPROT is copied from FLASH into FPROT. Bits 0, 1, and 2 are not used and each always reads as 0. This register can be read at any time, but user program writes have no meaning or effect. BACKGROUND DEBUG commands can write to FPROT.

\$1824	7	6	5	4	3	2	1	0
R	FPS7	FPS6	FPS5	FPS4	FPS3	FPS2	FPS1	FPDIS
W	(1)	(1)	(1)	(1)	(1)	(1)	(1)	(1)

Reset: This register is loaded from nonvolatile location NVPROT during reset.

- Background commands can be used to change the contents of these bits in FPROT.

Figure 15. FLASH Protection Register (FPROT)

Table 15. FPROT Register Field Descriptions

Field	Description
7:1 FPS[7:1]	FLASH Protect Select Bits — When FPDIS = 0, this 7-bit field determines the ending address of unprotected FLASH locations at the high address end of the FLASH. Protected FLASH locations cannot be erased or programmed.
0 FPDIS	FLASH Protection Disable 0 FLASH block specified by FPS[7:1] is block protected (program and erase not allowed) 1 No FLASH block is protected

4.9.5 FLASH Status Register (FSTAT)

Bits 3, 1, and 0 always read 0 and writes have no meaning or effect. The remaining five bits are status bits that can be read at any time. Writes to these bits have special meanings that are discussed in the bit descriptions.

\$1825	7	6	5	4	3	2	1	0
R	FCBEF	FCCF	FPVIOL	FACCERR	0	FBLANK	0	0
W								
Reset:	1	1	0	0	0	0	0	0
	= Reserved							

Figure 16. FLASH Status Register (FSTAT)

Table 16. FSTAT Register Field Descriptions

Field	Description
7 FCBEF	FLASH Command Buffer Empty Flag — The FCBEF bit is used to launch commands. It also indicates that the command buffer is empty so that a new command sequence can be executed when performing burst programming. The FCBEF bit is cleared by writing a one to it or when a burst program command is transferred to the array for programming. Only burst program commands can be buffered. 0 Command buffer is full (not ready for additional commands) 1 A new burst program command can be written to the command buffer

Table 16. FSTAT Register Field Descriptions (continued)

Field	Description
6 FCCF	FLASH Command Complete Flag — FCCF is set automatically when the command buffer is empty and no command is being processed. FCCF is cleared automatically when a new command is started (by writing 1 to FCBEF to register a command). Writing to FCCF has no meaning or effect. 0 Command in progress 1 All commands complete
5 FPVIOL	Protection Violation Flag — FPVIOL is set automatically when FCBEF is cleared to register a command that attempts to erase or program a location in a protected block (the erroneous command is ignored). FPVIOL is cleared by writing a 1 to FPVIOL. 0 No protection violation 1 An attempt was made to erase or program a protected location
4 FACCERR	Access Error Flag — FACCERR is set automatically when the proper command sequence is not obeyed exactly (the erroneous command is ignored), if a program or erase operation is attempted before the FCDIV register has been initialized, or if the MCU enters STOP while a command was in progress. For a more detailed discussion of the exact actions that are considered access errors, see Section 4.7.5 . FACCERR is cleared by writing a 1 to FACCERR. Writing a 0 to FACCERR has no meaning or effect. 0 No access error 1 An access error has occurred
2 FBLANK	FLASH Verified as All Blank (erased) Flag — FBLANK is set automatically at the conclusion of a blank check command if the entire FLASH array was verified to be erased. FBLANK is cleared by clearing FCBEF to write a new valid command. Writing to FBLANK has no meaning or effect. 0 After a blank check command is completed and FCCF = 1, FBLANK = 0 indicates the FLASH array is not completely erased 1 After a blank check command is completed and FCCF = 1, FBLANK = 1 indicates the FLASH array is completely erased (all 0xFF)

4.9.6 FLASH Command Register (FCMD)

Only five command codes are recognized in normal user modes as shown in [Table 17](#). Refer to [Section 4.7.3](#), for a detailed discussion of FLASH programming and erase operations.

\$1826	7	6	5	4	3	2	1	0
R	0	0	0	0	0	0	0	0
W	FCMD7	FCMD6	FCMD5	FCMD4	FCMD3	FCMD2	FCMD1	FCMD0
Reset:	0	0	0	0	0	0	0	0

Figure 17. FLASH Command Register (FCMD)

Table 17. FLASH Commands

Command	FCMD	Equate File Label
Blank check	0x05	mBlank
Byte program	0x20	mByteProg
Byte program — burst mode	0x25	mBurstProg
Page erase (512 bytes/page)	0x40	mPageErase
Mass erase (all FLASH)	0x41	mMassErase

All other command codes are illegal and generate an access error.

It is not necessary to perform a blank check command after a mass erase operation. Only blank check is required as part of the security unlocking mechanism.

5 Reset, Interrupts and System Configuration

This section discusses basic reset and interrupt mechanisms and the various sources of reset and interrupts in the FXTH870x6. Some interrupt sources from peripheral modules are discussed in greater detail within other sections of this product specification. This section gathers basic information about all reset and interrupt sources in one place for easy reference. A few reset and interrupt sources, including the computer operating properly (COP) watchdog and real-time interrupt (RTI), are not part of on-chip peripheral systems, but are part of the system control logic.

5.1 Features

Reset and interrupt features include:

- Multiple sources of reset for flexible system configuration and reliable operation
- Reset status register (SRS) to indicate source of most recent reset
- Separate interrupt vectors for each module (reduces polling overhead)

5.2 MCU Reset

Resetting the MCU provides a way to start processing from a known set of initial conditions. During reset, most control and status registers are forced to initial values and the program counter is loaded from the reset vector (\$DFFE:\$DFFF). On-chip peripheral modules are disabled and any I/O pins are initially configured as general-purpose high-impedance inputs with any pullup devices disabled. The I bit in the condition code register (CCR) is set to block maskable interrupts so the user program has a chance to initialize the stack pointer (SP) and system control settings. The SP is forced to \$00FF at reset. The FXTH870x6 has seven sources for reset:

- Power-on reset (POR)
- Low-voltage detect (LVD)
- Computer operating properly (COP) timer
- Periodic hardware reset (PRST)
- Illegal opcode detect
- Illegal address detect
- BACKGROUND DEBUG forced reset

Each of these sources has an associated bit in the system reset status register with the exception of the BACKGROUND DEBUG forced reset and the periodic hardware reset, PRST, that is indicated by the PRF bit in the PWUCS1 register.

5.3 Computer Operating Properly (COP) Watchdog

The COP watchdog is intended to force a system reset when the application software fails to execute as expected. To prevent a system reset from the COP timer (when it is enabled), application software must reset the COP timer periodically. If the application program gets lost and fails to reset the COP before it times out, a system reset is generated to force the system back to a known starting point. The COP watchdog is enabled by the COPE bit in SIMOPT1 register. The COP timer is reset by writing any value to the address of SRS. This write does not affect the data in the read-only SRS. Instead, the act of writing to this address is decoded and sends a reset signal to the COP timer.

The timeout period can be selected by the COPCLKS and the COPT[2:0] bits as shown in [Table 18](#). The COPCLKS bit selects either the LFO or the CPU bus clock as the clocking source and the COPT[2:0] bits select the clock count required for a timeout. The tolerances of these timeout periods is dependent on the selected clock source (LFO or HFO).

Table 18. COP Watchdog Timeout Period

COPCLKS	COPT			Clock Source	COP Overflow Count	COP Overflow Time (ms, nominal)
	2	1	0			
0	0	0	0	LFO	2 ⁵	32
0	0	0	1	LFO	2 ⁶	64
0	0	1	0	LFO	2 ⁷	128
0	0	1	1	LFO	2 ⁸	256
0	1	0	0	LFO	2 ⁹	512
0	1	0	1	LFO	2 ¹⁰	1024

Table 18. COP Watchdog Timeout Period (continued)

COPCLKS	COPT			Clock Source	COP Overflow Count	COP Overflow Time (ms, nominal)			
	2	1	0			BUSCLKS[1:0]			
0	1	1	0	LFO	2^{11}	2048			
0	1	1	1	LFO	2^{11}	2048			
						BUSCLKS[1:0]			
						1:1 (0.5 MHz)	1:0 (1 MHz)	0:1 (2 MHz)	0:0 (4MHz)
1	0	0	0	Bus Clock	2^{13}	16.384	8.192	4.096	2.048
1	0	0	1	Bus Clock	2^{14}	32.768	16.384	8.192	4.096
1	0	1	0	Bus Clock	2^{15}	65.536	32.768	16.384	8.192
1	0	1	1	Bus Clock	2^{16}	131.072	65.536	32.768	16.384
1	1	0	0	Bus Clock	2^{17}	262.144	131.072	65.536	32.768
1	1	0	1	Bus Clock	2^{18}	524.288	262.144	131.072	65.536
1	1	1	0	Bus Clock	2^{19}	1048.576	524.288	262.144	131.072
1	1	1	1	Bus Clock	2^{19}	1048.576	524.288	262.144	131.072

After any reset, the COP timer is enabled. This provides a reliable way to detect code that is not executing as intended. If the COP watchdog is not used in an application, it can be disabled by clearing the COPE bit in the write-once SIMOPT1 register. Even if the application will use the reset default settings in COPE, COPCLKS and COPT[2:0], the user should still write to write-once SIMOPT1 during reset initialization to lock in the settings. That way, they cannot be changed accidentally if the application program gets lost.

The write to SRS that services (clears) the COP timer should not be placed in an interrupt service routine (ISR) because the ISR could continue to be executed periodically even if the main application program fails. When the MCU is in ACTIVE BACKGROUND DEBUG mode, the COP timer is temporarily disabled.

5.4 SIM Test Register (SIMTST)

The output of the temperature monitor is available using the SIM Test register as shown in Figure 18.

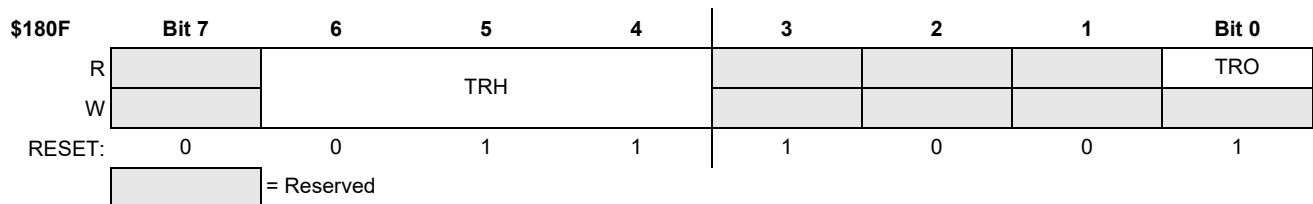

Figure 18. SIM Test Register (SIMTST)

Table 19. SIMTST Register Field Descriptions

Field	Description
7 reserved	Reserved Bit — These bits are reserved for factory trim and should not be altered by the user.
6:4 TRH	Temperature Restart High threshold — Binary coded from 0x00 to 0x07; recommend applications overwrite to 0x06 at each wakeup cycle.
3:1 reserved	Reserved Bit — These bits are reserved for factory trim and should not be altered by the user.
0 TRO	Temperature Restart Outside 1 TR module is outside the T_{REARM} temperature range and will restart the MCU if the TRE bit is set and temperature falls back within the T_{RESET} temperature range. 0 TR module is within the T_{RESET} temperature range and the MCU cannot be armed to restart when temperature falls back to the T_{RESET} range. The TRE bit cannot be set.

5.5 Interrupts

Interrupts provide a way to save the current CPU status and registers, execute an interrupt service routine (ISR), and then restore the CPU status so processing resumes where it left off before the interrupt. Other than the software interrupt (SWI), which is a program instruction, interrupts are caused by hardware events. The debug module can also generate an SWI under certain circumstances.

If an event occurs in an enabled interrupt source, an associated read-only status flag will become set. The CPU will not respond until and unless the local interrupt enable is a logic 1 to enable the interrupt. The I bit in the CCR must be a logic 0 to allow interrupts. The global interrupt mask (I bit) in the CCR is initially set after reset which masks (prevents) all maskable interrupt sources. The user program initializes the stack pointer and performs other system setup before clearing the I bit to allow the CPU to respond to interrupts. When the CPU receives a qualified interrupt request, it completes the current instruction before responding to the interrupt. The interrupt sequence follows the same cycle-by-cycle sequence as the SWI instruction and consists of:

- Saving the CPU registers on the stack
- Setting the I bit in the CCR to mask further interrupts
- Fetching the interrupt vector for the highest-priority interrupt that is currently pending
- Filling the instruction queue with the first three bytes of program information starting from the address fetched from the interrupt vector locations

While the CPU is responding to the interrupt, the I bit is automatically set to avoid the possibility of another interrupt interrupting the ISR itself (this is called nesting of interrupts). Normally, the I bit is restored to 0 when the CCR is restored from the value stacked on entry to the ISR. In rare cases, the I bit may be cleared inside an ISR (after clearing the status flag that generated the interrupt) so that other interrupts can be serviced without waiting for the first service routine to finish. This practice is not recommended for anyone other than the most experienced programmers because it can lead to subtle program errors that are difficult to debug.

The interrupt service routine ends with a return-from-interrupt (RTI) instruction which restores the CCR, A, X, and PC registers to their pre interrupt values by reading the previously saved information off the stack.

When two or more interrupts are pending when the I bit is cleared, the highest priority source is serviced first.

For compatibility with the M68HC08, the H register is not automatically saved and restored. It is good programming practice to push H onto the stack at the start of the interrupt service routine (ISR) and restore it just before the RTI that is used to return from the ISR.

5.5.1 Interrupt Stack Frame

Figure 18 shows the contents and organization of a stack frame. Before the interrupt, the stack pointer (SP) points at the next available byte location on the stack. The current values of CPU registers are stored on the stack starting with the low-order byte of the program counter (PCL) and ending with the CCR. After stacking, the SP points at the next available location on the stack which is the address that is one less than the address where the CCR was saved. The PC value that is stacked is the address of the instruction in the main program that would have executed next if the interrupt had not occurred.

When an RTI instruction is executed, these values are recovered from the stack in reverse order. As part of the RTI sequence, the CPU fills the instruction pipeline by reading three bytes of program information, starting from the PC address just recovered from the stack.

The status flag causing the interrupt must be acknowledged (cleared) before returning from the ISR. Typically, the flag should be cleared at the beginning of the ISR so that if another interrupt is generated by this same source, it will be registered so it can be serviced after completion of the current ISR.

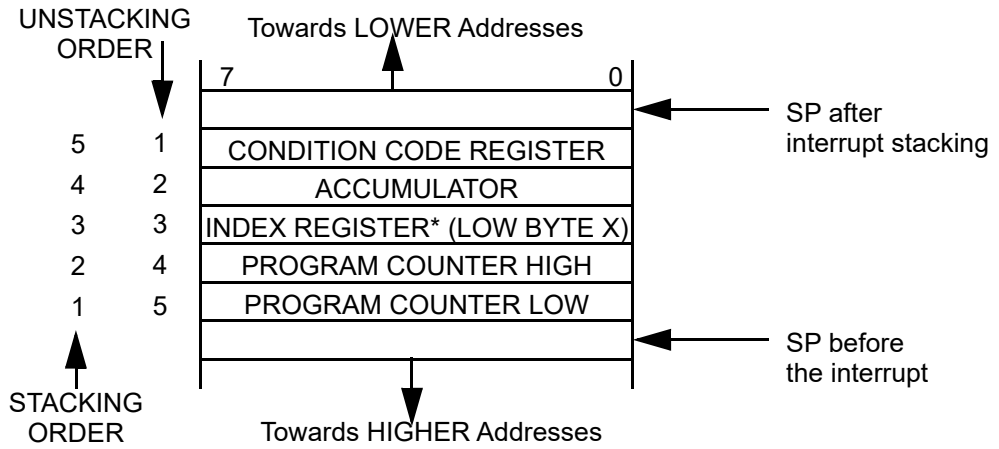

* High byte (H) of index register is not automatically stacked.

Figure 19. Interrupt Stack Frame

5.5.2 Vector Summary

Table 20 provides a summary of all interrupt sources. Higher-priority sources are located toward the bottom of the table (at the higher vector addresses). All of these vectors are a 2-byte address that the firmware uses as the destination address. This allows the firmware to intercept all vectors and add additional processing as needed. The additional process latency for each interrupt will be described in Section 14.

Therefore, the high-order byte of the address for the user's interrupt service routine is located at the lower address in the vector address column, and the low-order byte of the address for the interrupt service routine is located at the higher address. When an interrupt condition occurs, an associated flag bit becomes set. If the associated local interrupt enable is set, an interrupt request is sent to the CPU. Within the CPU, if the global interrupt mask (I bit in the CCR) is 0, the CPU will finish the current instruction, stack the PCL, PCH, X, A, and CCR CPU registers, set the I bit, and then fetch the interrupt vector for the highest priority pending interrupt. Processing then continues in the interrupt service routine.

The triggering of any of these vector fetches will wake the MCU from any of the STOP modes.

Table 20. Vector Summary

Vector Priority	Vector No.	Jump Table Vector Addr (High/Low)	Vector Name	Module Source	Flags	Enables	Description	
Lower  Higher	15	\$DFE0 - \$DFE1	Vkbi	KBI	KBF	KBIE	Keyboard interrupt pins PTA[3:0]	
	14	\$DFE2 - \$DFE3	Reserved					
	13	\$DFE4 - \$DFE5	Reserved					
	12	\$DFE6 - \$DFE7	Vrti	Sys Ctrl	RTIF	RTIE	Interrupt from the RTI when the periodic wakeup timer has timed out.	
	11	\$DFE8 - \$DFE9	Vlfrcvr	LFR	LFIDF	LFIDIE	Interrupt from LFR in data mode when a valid wake ID has been received.	
					LFCDF	LFCDIE	Interrupt from LFR in carrier mode when a carrier present for the required time.	
					LFERF	LFERIE	Interrupt from LFR in the manchester decode mode when an error is detected.	
					LFDRF	LFDRIE	Interrupt from LFR in the manchester decode mode when an 8-bit data byte has been successfully received.	
	10	\$DFEA - \$DFEB	Reserved					
	9	\$DFEC - \$DFED	Vrf	RFM	RFIF	RFIEN	Interrupt from the RFM when the data buffer has been completely sent.	
					RFEF		Interrupt from the RFM when transmission error detected.	
	8	\$DFEE - \$DFEF	Reserved					
	7	\$DFF0 - \$DFF1	Vtpm1ovf	TPM1	TOF	TOIE	Interrupt from the TPM1 when the timer overflows.	
	6	\$DFF2 - \$DFF3	Vtpm1ch1	TPM1	CH1F	CH1IE	Interrupt from the TPM1 when the selected event for channel 1 occurs.	
	5	\$DFF4 - \$DFF5	Vtpm1ch0	TPM1	CH0F	CH0IE	Interrupt from the TPM1 when the selected event for channel 0 occurs.	
	4	\$DFF6 - \$DFF7	Vwuktmr	PWU	WUKI	WUK[5:0]	Interrupt from the PWU when the wakeup time interval has elapsed.	
3	\$DFF8 - \$DFF9	Vlvd	Sys Ctrl	LVDF	LVDIE	Interrupt from the LVD when the supply voltage has dropped below the LVD threshold.		
2	\$DFFA - \$DFFB	Reserved						
1	\$DFFC - \$DFFD	Vswi	SWI opcode	—	—	Interrupt from the CPU when an SWI instruction has been executed.		
0	\$DFFE - \$DFFF	Vreset	Sys Ctrl - POR	—	—	Reset from power on sequence.		
			Sys Ctrl - PRF	PRF	PRST[5:0]	Reset from PWU when the reset interval elapsed.		
			Sys Ctrl - COP	—	COPE	Reset when COP watchdog times out.		
			Sys Ctrl - LVD	—	LVDRE	Reset from the LVD when the supply voltage has dropped below the LVD threshold.		
			Temp Restart	—	TRE	Reset when the temperature falls below the temperature restart threshold		
			Illegal opcode	—	—	Reset from the CPU when trying to execute an illegal opcode.		
			Illegal address	—	—	Reset from the CPU when trying to access an illegal address.		

5.6 Low-Voltage Detect (LVD) System

The FXTH870x6 includes a system to detect low voltage conditions in order to protect memory contents and control MCU system states during supply voltage variations. The system is comprised of a power-on reset (POR) circuit and an LVD circuit with a user selectable trip voltage, either high (V_{LVDH}) or low (V_{LVDL}). The LVD circuit is enabled when LVDE in SPMSC1 is high and the trip voltage is selected by LVDV in SPMSC3. The LVD is disabled upon entering any of the STOP modes unless the LVDSE bit is set. If LVDSE and LVDE are both set, then the MCU cannot enter STOP1.

5.6.1 Power-On Reset Operation

When power is initially applied to the FXTH870x6, or when the supply voltage drops below the V_{POR} level, the POR circuit will cause a reset condition. As the supply voltage rises, the LVD circuit will hold the chip in reset until the supply has risen above the level determined by LVDV bit. Both the POR bit and the LVD bit in SRS are set following a POR.

5.6.2 LVD Reset Operation

The LVD can be configured to generate a reset upon detection of a low voltage condition has occurred by setting LVDRE to 1 when the supply voltage has fallen below the level determined by LVDV bit. After an LVD reset has occurred, the LVD system will hold the FXTH870x6 in reset until the supply voltage has risen above the level determined by LVDV bit. The threshold for falling and rising differ by a small amount of hysteresis. The LVD bit in the SRS register is set following either an LVD reset or POR.

5.6.3 LVD Interrupt Operation

When a low voltage condition is detected and the LVD circuit is configured for interrupt operation (LVDE set, LVDIE set, and LVDRE clear), then LVDF will be set and an LVD interrupt will occur.

5.6.4 Low-Voltage Warning (LVW)

The LVD system has a low voltage warning flag, LVWF, to indicate to the user that the supply voltage is approaching, but is still above, the LVD reset voltage. The LVWF can be reset by writing a logical one to the LVWACK bit. The LVW does not have an interrupt associated with it. There are two user selectable trip voltages for the LVW as selected by LVWV in SPMSC3. The LVWF is set when the supply voltage falls below the selected level and cannot be reset until the supply voltage has risen above the selected level. The threshold for falling and rising differ by a small amount of hysteresis.

5.7 System Clock Control

Several clock rate selections are possible with the FXTH870x6 using the BUSCLKS[1:0] control bits to select the clock frequency division of the HFO as given in [Table 21](#). These bits are cleared by any MCU reset.

Table 21. HFO Frequency Selections

BUSCLKS1	BUSCLKS0	HFO Frequency (MHz)	CPU Bus Frequency (MHz)
0	0	8	4
0	1	4	2
1	0	2	1
1	1	1	0.5

5.8 Keyboard Interrupts

The keyboard interrupts can be used to wake the MCU. These are assigned to specific general I/O pins as given in [Table 22](#).

Table 22. Keyboard Interrupt Assignments

KBI	Pin	Pin Function
0	PTA0	General I/O
1	PTA1	General I/O
2	PTA2	General I/O
3	PTA3	General I/O

5.9 Real Time Interrupt

The RTI uses the internal low frequency oscillator (LFO) as its clock source. The RTI can be used as a periodic interrupt in MCU RUN mode, or can be used as a periodic wakeup from all low power modes. The LFO is always active and cannot be powered off by any software control. The control bits for the RTI are shown in [Figure 20](#).

\$1808	Bit 7	6	5	4	3	2	1	Bit 0
R	RTIF	0	RTICLKS	RTIE	0	RTIS[2:0]		
W		RTIACK						
RESET:	0	0	0	0	0	0	0	0
POR:	0	0	0	0	0	0	0	0
	<div style="border: 1px solid black; width: 50px; height: 15px; display: inline-block;"></div> = Reserved							

Figure 20. RTI Status/Control Register (SRTISC)

Table 23. SRTISC Register Field Descriptions

Field	Description
7 RTIF	RTI Interrupt Flag — The RTIF bit indicates when a wakeup interrupt has been generated by the RTI. This bit is cleared by writing a one to the RTIACK bit. Writing a zero to this bit has no effect. Reset clears this bit. 0 Wakeup interrupt not generated or was previously acknowledged. 1 Wakeup interrupt generated.
6 RTIACK	Acknowledge RTIF Interrupt Flag — The RTIACK bit clears the RTIF bit if written with a one. Writing a zero to the RTIACK bit has no effect on the RTIF bit. Reading the RTIACK bit returns a zero. Reset has no effect on this bit. 0 No effect. 1 Clear RTIF bit.
5 RTICLKS	RTI Interrupt Clock Select — This read-write bit selects the clock source for the real-time interrupt request 0 Real-time interrupt request clock source is the LFO. 1 Real-time interrupt request clock source is the HFO (MCU must be in the RUN mode).
4 RTIE	RTIF Interrupt Enable — The RTIE bit enables RTI interrupts if written with a one. Reset clears this bit. 0 Disable RTI interrupts. 1 Enable RTI interrupts.
3 Unused	Unused
2:0 RTIS[2:0]	RTI Interrupt Delay Selects — The RTIS[2:0] bits select the timing of the RTI interrupts as given in Table 24 . Reset clears these bits.

Table 24. Real-Time Interrupt Period

RTIS2	RTIS1	RTIS0	Delay Timing (ms) (Dependent on 1-kHz LFO)
0	0	0	OFF
0	0	1	2
0	1	0	4
0	1	1	8
1	0	0	16
1	0	1	32
1	1	0	64
1	1	1	128

5.10 Temperature Sensor and Restart System

The FXTH870x6 has two temperature sensing mechanisms. The first is an accurate sensor which is accessible through the ADC10 channel 1. The second is a less accurate, very low power sensor which generates a wakeup from STOP1 when the temperature crosses its threshold of detection. This is the temperature restart wakeup which is used as follows:

1. The temperature restart wakeup is enabled by software following detection of an over temperature condition using the temperature sensor connected to the ADC10.
2. User software enables the temperature restart detector and then instructs the MCU to enter STOP1 mode to halt execution during the out-of-range temperature condition.
3. When the temperature crosses the temperature restart threshold back into the normal range of operation, a wakeup is generated to wake the MCU. Exit from STOP1 will reset the device.

The temperature sensor is enabled whenever the ADC10 is enabled. The temperature restart wakeup is enabled by setting the TRE bit in SIMOPT1 register and whether the detector interrupts the MCU from a very low or a very high temperature is determined by the TRH bit in the SIMOPT1 register.

5.11 Reset, Interrupt and System Control Registers And Bits

One 8-bit register in the direct page register space and eight 8-bit registers in the high-page register space are related to reset and interrupt systems.

5.11.1 System Reset Status Register (SRS)

The SRS register at \$1800 includes seven read-only status flags to indicate the source of the most recent reset. When a debug host forces reset by writing 1 to BDFR in the SBDFR register, none of the status bits in SRS will be set. Writing any value to this register address clears the COP watchdog timer without affecting the contents of this register. The reset state of these bits depends on what caused the MCU to reset.

\$1800	Bit 7	6	5	4	3	2	1	Bit 0
R	POR	PIN	COP	ILOP	ILAD	PWU	LVD	0
W								
POR Reset:	1	0	0	0	0	0	1	0
LVD Reset:	1	0	0	0	0	0	1	0
Any Other Reset:	0	(1)	(1)	(1)	(1)	0	0	0

= Reserved

1. Any of these reset sources that are active at the time of reset will cause the corresponding bit(s) to be set; bits corresponding to sources that are not active at the time of reset will be cleared.

Figure 21. System Reset Status Register (SRS)

Table 25. SRS Register Field Descriptions

Field	Description
7 POR	Power-On Reset — This bit indicates reset was caused by the power-on detection logic. Because the internal supply voltage was ramping up at the time, the low-voltage reset (LVR) status bit is also set to indicate that the reset occurred while the internal supply was below the LVR threshold. 0 Reset not caused by POR 1 POR caused reset
6 PIN	External Reset Pin — This bit indicates reset was caused by an active-low level on the external reset pin if the device was in either the STOP1 or RUN modes. This bit is not set if the external reset pin is pulled low when the device is in the STOP1 mode. 0 Reset not caused by external reset pin 1 Reset came from external reset pin
5 COP	Computer Operating Properly (COP) Watchdog — This bit indicates that reset was caused by the COP watchdog timer timing out. This reset source may be blocked by COPE = 0. 0 Reset not caused by COP timeout 1 Reset caused by COP timeout
4 ILOP	Illegal Opcode — This bit indicates reset was caused by an attempt to execute an unimplemented or illegal opcode. The STOP instruction is considered illegal if STOP is disabled by STOPE = 0 in the SOPT register. The BGND instruction is considered illegal if ACTIVE BACKGROUND mode is disabled by ENBDM = 0 in the BDCSC register. 0 Reset not caused by an illegal opcode 1 Reset caused by an illegal opcode
3 ILAD	Illegal Address — This bit indicates reset was caused by an attempt to access either data or an instruction at an unimplemented memory address. 0 Reset not caused by an illegal address 1 Reset caused by an illegal address
2 PWU	Programmable Wakeup — This bit indicates reset was caused by a PWU reset in run, WAIT, STOP4, and STOP3. After STOP1 exit, PRF in PWUCSI indicates PWU was the source of a wakeup. 0 Reset not caused by PWU. 1 Reset caused by PWU.
1 LVD	Low Voltage Detect — If the LVDRE and LVDSE bits are set and the supply drops below the LVD trip voltage, an LVD reset will occur. This bit is also set by POR. 0 Reset not caused by LVD trip or POR. 1 Reset caused by LVD trip or POR.
0 Unused	Unused Bit — This bit always reads as a logical zero. Writes

5.11.2 System Options Register 1 (SIMOPT1)

The following clock source and frequency selections are available using the system option register 1 as shown in [Figure 22](#).

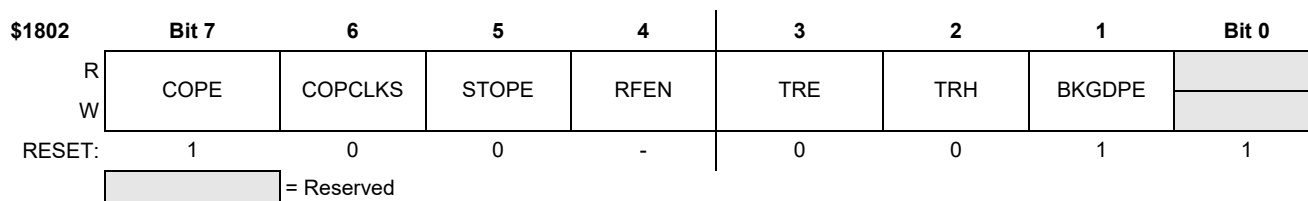

Figure 22. System Option Register 1 (SIMOPT1)

Table 26. SIMOPT1 Register Field Descriptions

Field	Description
7 COPE	COP Enable — This control bit enables the COP watchdog. This bit is a write-once bit so that only the first write after reset is honored. Reset sets the COPE bit. 0 COP Watchdog disabled. 1 COP Watchdog enabled.

Table 26. SIMOPT1 Register Field Descriptions (continued)

Field	Description
6 COPCLKS	COP Clock Select — This control bit selects the clock source for the COP watchdog timer. This bit is a write-once bit so that only the first write after reset is honored. This bit is cleared by an MCU reset. 0 Select the LFO oscillator output. 1 Select the CPU bus clock.
5 STOPE	STOP Mode Select — This control bit enables/disables the STOP instruction to enter a STOP mode defined by the SPMSCR2 register. This bit is a write-once bit so that only the first write after reset is honored. This bit is cleared by an MCU reset. 0 Disable STOP modes. 1 Enable STOP modes.
4 RFEN	RF Module Enable — This bit enables or disables the RF module. This bit is not affected by any reset or power on after STOP exit. It is only initialized at the first power up. This bit can be written anytime. 1 RF module enabled. 0 RF module disabled.
3 TRE	Temperature Restart Enable — This control bit enables the temperature restart circuit to interrupt the MCU after being shutdown at either a very high or very low temperature. This bit is cleared by an MCU reset. 0 Temperature restart disabled. 1 Temperature restart enabled.
2 TRH	Temperature Restart Level — This control bit selects whether the temperature restart circuit will interrupt the MCU after being shutdown on returning from either a very high or very low temperature. This bit is cleared by an MCU reset. 0 Temperature restart interrupts MCU on return from a very low temperature. 1 Temperature restart interrupts MCU on return from a very high temperature.
1 BKGDPE	BKGD Pin Enable — BKGDPE can be used to allow the BKGD/PTA4 pin to be shared in applications as an input-only general purpose I/O pin: 0 BKGD function disabled, PTA4 enabled. 1 BKGD function enabled, PTA4 disabled.
0 Reserved	Reserved register bit, always reads 1.

5.11.3 System Operation Register 2 (SIMOPT2)

The following clock source and frequency selections are available using the system option register 2 as shown in [Figure 23](#).

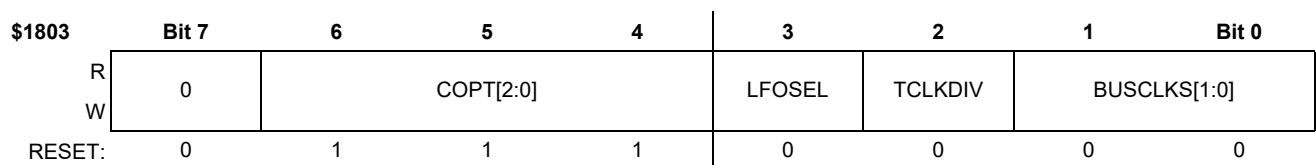

Figure 23. System Option Register 2 (SIMOPT2)

Table 27. SIMOPT2 Register Field Descriptions

Field	Description
7 Unused	Unused Bit — This bit is unused and reads as a logic zero.
6:4 COPT[2:0]	COP Watchdog Time Out — These control bits select the timeout period for the COP watchdog timer as given in Table 18 . These bits are set by an MCU reset to select the longest watchdog timeout period. These bits are write-once after power up.
3 LFOSEL	TPM1 Channel 0 Clock Source — This bit determines which signal is connected to the TPM1 Channel 0, see Section 9 . 0 Select clock input driven by PTA2. 1 Select clock input driven by the LFO.
2 TCLKDIV	TPM1 Channel 0 Clock Source Divider — The divider for the clock Source for TPM1 Channel 0, see Section 9 . 0 Select RfM Dx clock source divided by 1. 1 Select RfM Dx clock source divided by 8.

Table 27. SIMOPT2 Register Field Descriptions (continued)

Field	Description
1:0 BUSCLKS [1:0]	Bus Clock Select — Bus clock frequency selection by changing HFO FLL ratio as shown in Figure 2. The bus clock frequency is always the HFO frequency divided by two. These bits are cleared by a reset and can be written at any time. 00 Bus Frequency = 4 MHz (HFO = 8 MHz) 01 Bus Frequency = 2 MHz (HFO = 4 MHz) 10 Bus Frequency = 1 MHz (HFO = 2 MHz) 11 Bus Frequency = 0.5 MHz (HFO = 1 MHz)

5.11.4 System Power Management Status and Control 1 Register (SPMSC1)

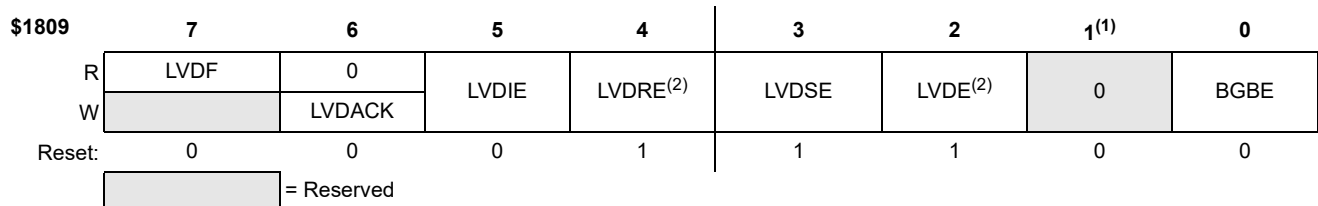

1. Bit 1 is a reserved bit that must always be written to 0.
2. This bit can be written only one time after reset. Additional writes are ignored.

Figure 24. System Power Management Status and Control 1 Register (SPMSC1)

Table 28. SPMSC1 Register Field Descriptions

Field	Description
7 LVDF	Low-Voltage Detect Flag — Provided LVDE = 1, this read-only status bit indicates a low-voltage detect event.
6 LVDACK	Low-Voltage Detect Acknowledge — This write-only bit is used to acknowledge low voltage detection errors (write 1 to clear LVDF). Reads always return logic 0.
5 LVDIE	Low-Voltage Detect Interrupt Enable — This read/write bit enables hardware interrupt requests for LVDF. 0 Hardware interrupt disabled (use polling) 1 Request a hardware interrupt when LVDF = 1
4 LVDRE	Low-Voltage Detect Reset Enable — This read/write bit enables LVDF events to generate a hardware reset (provided LVDE = 1). 0 LVDF does not generate hardware resets 1 Force an MCU reset when LVDF = 1
3 LVDSE	Low-Voltage Detect Stop Enable — Provided LVDE = 1, this read/write bit determines whether the low-voltage detect function operates when the MCU is in STOP mode. 0 Low-voltage detect disabled during STOP mode 1 Low-voltage detect enabled during STOP mode
2 LVDE	Low-Voltage Detect Enable — This read/write bit enables low-voltage detect logic and qualifies the operation of other bits in this register. 0 LVD logic disabled 1 LVD logic enabled
0 Reserved	Reserved Bit — This bit is reserved should not be altered by the user. Any read returns a logical zero. Any write should be a logical zero.
0 BGBE	Bandgap Buffer Enable — The BGBE bit is used to enable an internal buffer for the bandgap voltage reference for use by the ADC module on one of its internal channels. 0 Bandgap buffer disabled 1 Bandgap buffer enabled

5.11.5 System Power Management Status and Control 2 Register (SPMSC2)

This register is used to configure the STOP mode behavior of the MCU.

\$180A	7	6	5	4	3	2	1	0
R	0	0	0	PDF	0	0	PDC ⁽¹⁾	0
W						PPDACK		
Power-on reset:	0	0	0	0	0	0	0	0
Any other reset:	0	0	U	U	0	0	0	0

= Reserved
 U = Unaffected by reset

1. This bit can be written only one time after reset. Additional writes are ignored.

Figure 25. System Power Management Status and Control 2 Register (SPMSC2)

Table 29. SPMSC2 Register Field Descriptions

Field	Description
7:5 Reserved	Reserved Bits — These bits are reserved should not be altered by the user. Any read returns a logical zero.
4 PDF	Power Down Flag — This read-only status bit indicates the MCU has recovered from STOP1 mode. 0 MCU has not recovered from STOP1 mode 1 MCU recovered from STOP1 mode
3 Reserved	Reserved Bit — This bit is reserved should not be altered by the user. Any read returns a logical zero.
2 PPDACK	Partial Power Down Acknowledge — Writing a logic 1 to PPDACK clears the PDF bit.
1 PDC	Power Down Control — The PDC bit controls entry into the power down (STOP1) mode 0 Power down mode are disabled 1 Power down mode are enabled
0 Reserved	Reserved Bit — This bit is reserved should not be altered by the user. Any read returns a logical zero. Any write should be a logical zero.

5.11.6 System Power Management Status and Control 3 Register (SPMSC3)

\$180C	7	6	5	4	3	2	1	0
R	LVWF	0	LVDV	LVWV	0	0	0	0
W		LVWACK						
Power-on reset:	0 ⁽¹⁾	0	0	0	0	0	0	0
LVD reset:	0 ⁽¹⁾	0	U	U	0	0	0	0
Any other reset:	0 ⁽¹⁾	0	U	U	0	0	0	0

= Reserved
 U = Unaffected by reset

1. LVWF will be set in the case when V_{Supply} transitions below the trip point or after reset and V_{Supply} is already below V_{LVW} .

Figure 26. System Power Management Status and Control 3 Register (SPMSC3)

Table 30. SRTISC Register Field Descriptions

Field	Description
7 LVWF	Low-Voltage Warning Flag — The LVWF bit indicates the low voltage warning status. 0 Low voltage warning not present 1 Low voltage warning is present or was present

Table 30. SRTISC Register Field Descriptions (continued)

Field	Description
6 LVWACK	Low-Voltage Warning Acknowledge — The LVWF bit indicates the low voltage warning status. Writing a logic 1 to LVWACK clears LVWF to a logic 0 if a low voltage warning is not present.
5 LVDV	Low-Voltage Detect Voltage Select — The LVDV bit selects the LVD trip point voltage (V_{LVD}). 0 Low trip point selected ($V_{LVD} = V_{LVDL}$) 1 High trip point selected ($V_{LVD} = V_{LVDH}$)
4 LVVW	Low-Voltage Warning Voltage Select — The LVVW bit selects the LVW trip point voltage (V_{LVW}). 0 Low trip point selected ($V_{LVW} = V_{LVDL}$) 1 High trip point selected ($V_{LVW} = V_{LVDH}$)
3:0 Reserved	Reserved Bits — These bits are reserved should not be altered by the user. Any read returns a logical zero.

5.12 System STOP Exit Status Register (SIMSES)

The SIMSES register at \$180D can be used to determine the source of an MCU wakeup from the STOP modes. The flags are as shown in Figure 27. All of the flags are automatically cleared when the MCU goes into a STOP mode. Writes to any of these bits are ignored.

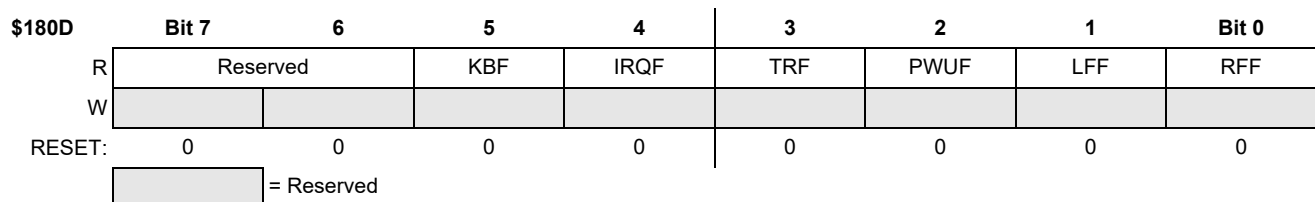

Figure 27. SIM STOP Exit Status (SIMSES)

Table 31. SIMSES Register Field Descriptions

Field	Description
7:6 Reserved	Reserved Bits — These bits are reserved for NXP firmware control. Application software shall assure these two bits are never overwritten.
5 KBF	Keyboard Flag — This bit indicates that any keyboard pin caused the last exit from STOP mode. 0 Keyboard pin did not cause the last exit from STOP mode 1 Keyboard pin caused the last exit from STOP mode
4 IRQF	IRQ Flag — This bit indicates that IRQ pin caused the last exit from STOP mode. 0 IRQ pin did not cause the last exit from STOP mode 1 IRQ pin caused the last exit from STOP mode
3 TRF	Temperature Restart Flag — This bit indicates that the temperature restart module caused the last exit from STOP mode. 0 TR module did not cause the last exit from STOP mode 1 TR module caused the last exit from STOP mode
2 PWUF	PWU Flag — This bit indicates that the PWU module caused the last exit from STOP mode. 0 PWU module did not cause the last exit from STOP mode 1 PWU module caused the last exit from STOP mode
1 LFF	LFR Flag — This bit indicates that the LFR module caused the last exit from STOP mode. 0 LFR module did not cause the last exit from STOP mode 1 LFR module caused the last exit from STOP mode
0 RFF	RFM Flag — This bit indicates that the RFM module caused the last exit from STOP mode. 0 RFM module did not cause the last exit from STOP mode 1 RFM module caused the last exit from STOP mode

6 General Purpose I/O

This section explains software controls related to general purpose input/output (I/O) and pin control. The FXTH870x6 has seven general-purpose I/O pins which are comprised of a general use 5-bit port A and a 2-bit port B.

PTA[4:0] pins are shared with on-chip peripheral functions. PTB[1:0] pins are GPIO only and are mutually exclusive with the LF receiver, such that PTB[1:0] pins become high impedance when the LF is enabled (see [Section 6.5](#) for additional details regarding mutually exclusive operations). The peripheral modules have priority over the general purpose I/O so that when a peripheral is enabled, the general purpose I/O functions associated with the shared pins are disabled. After reset, the shared peripheral functions are disabled so that the pins are controlled by the general purpose I/O. All of the general purpose I/O are configured as inputs (PTxDDn = 0) with pullup devices disabled (PTxPEn = 0).

To avoid extra current drain from floating input pins, the user's application software must configure these pins so that they do not float (see [Section 6.1](#)).

Reading and writing of general purpose I/O is performed through the port data registers. The direction, either input or output, is controlled through the port data direction registers. The general purpose I/O port function for an individual pin is illustrated in the block diagram in [Figure 28](#).

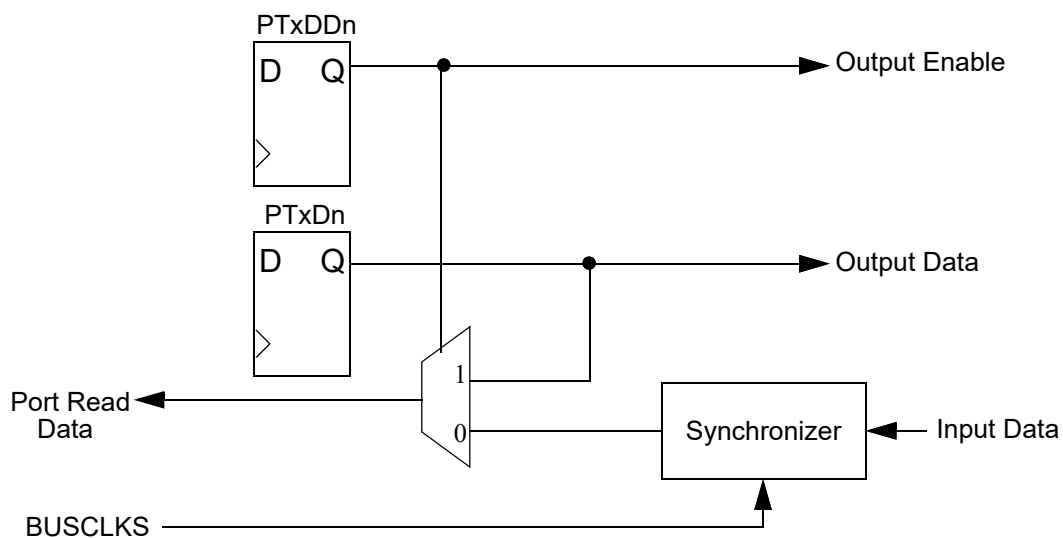

Figure 28. General Purpose I/O Block Diagram

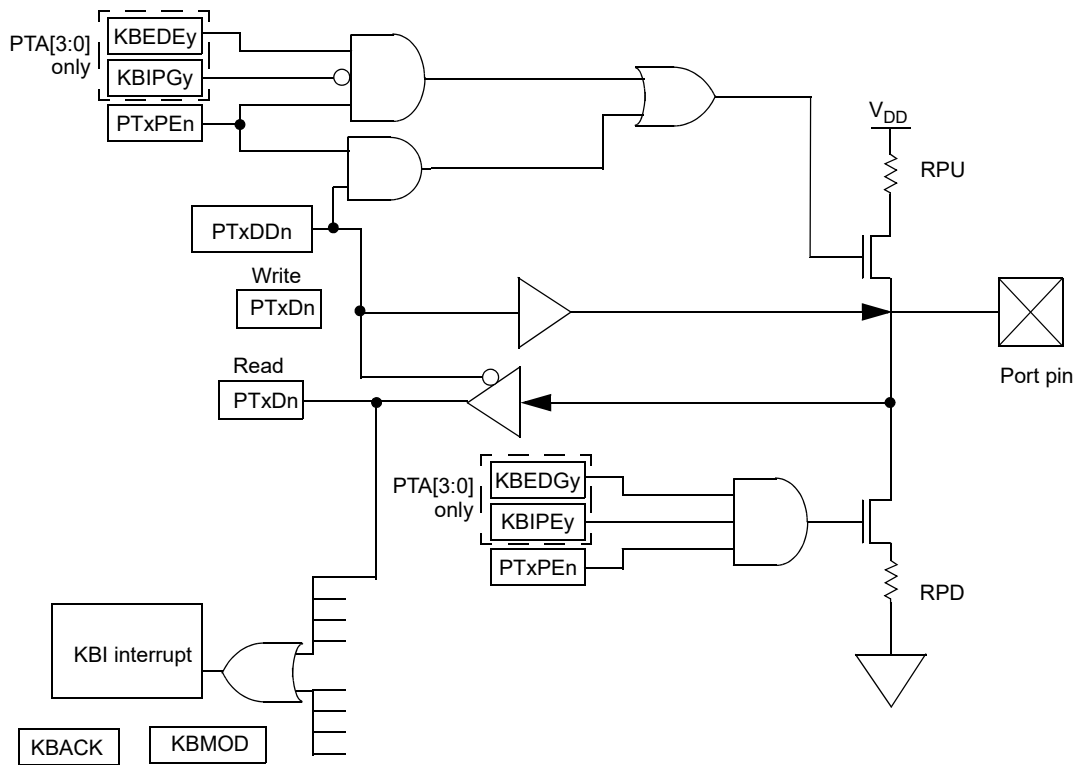

Figure 29. General Purpose I/O Logic

Table 32. Truth Table for Pullup and Pulldown Resistors

PTAPE[3:0] (pull enable)	PTADD[3:0] (data direction)	KBIPE[3:0] (KBI pin enable)	KBEDG[3:0] (KBI Edge Select)	Pullup	Pulldown
0	0	x	x	disabled	disabled
1	0	0	x	enabled	disabled
x	1	x	x	disabled	disabled
1	0	1	0	enabled	disabled
1	0	1	1	disabled	enabled
PTBPE[1:0] (pull enable)	PTBDD[1:0] (data direction)				
0	0	x	x	disabled	x
1	0	x	x	enabled	x
x	1	x	x	disabled	x

The data direction control bit (PTxDDn) determines whether the output buffer for the associated pin is enabled, and also controls the source for port data register reads. The input buffer for the associated pin is always enabled unless the pin is enabled as an analog function.

When a shared digital function is enabled for a pin, the output buffer is controlled by the shared function. However, the data direction register bit still controls the source for reads of the port data register.

When a shared analog function is enabled for a pin, both the input and output buffers are disabled. A value of 0 is read for any port data bit where the bit is an input (PTxDDn = 0) and the input buffer is disabled. In general, whenever a pin is shared with both an alternate digital function and an analog function, the analog function has priority such that if both the digital and analog functions are enabled, the analog function controls the pin.

It is a good programming practice to write to the port data register before changing the direction of a port pin to become an output. This ensures that the pin will not be driven momentarily with an old data value that happened to be in the port data register.

An internal pullup device can be enabled for each port pin by setting the corresponding bit in one of the pullup enable registers (PTxPEn). The pullup device is disabled if the pin is configured as an output by the general purpose I/O control logic or any shared peripheral function regardless of the state of the corresponding pullup enable register bit. The pullup device is also disabled if the pin is controlled by an analog function.

6.1 Unused Pin Configuration

Any general purpose I/O pins which are not used in the application must be properly configured to avoid a floating input that could cause excessive supply current, I_{DD} .

When the device comes out of the reset state the NXP supplied firmware will not configure any of the general purpose I/O pins.

Recommended configuration methods are:

1. Configure the general purpose I/O pin as an input (PTxDDn = 0) with the pin connected to the V_{DD} source; use a pullup resistor of 10-51 k Ω to assure sufficient noise immunity.
2. Configure the general purpose I/O pin as an input (PTxDDn = 0) with the internal pullup activated (PTxPEn = 1) and leave the pin disconnected.
3. Configure the general purpose I/O pin as an output (PTxDDn = 1) and drive the pin low (PTxDn = 0) and leave the pin disconnected.

In cases where GPIOs are directly connected to AV_{DD} , V_{DD} , AV_{SS} , V_{SS} or RV_{SS} , user application should configure the GPIO as an input with the internal pull-up disabled, in order to prevent software code faults from causing excessive supply current states should these pins become outputs.

6.2 Pin Behavior in STOP Modes

Pin behavior following execution of a STOP instruction depends on the STOP mode that is entered. An explanation of pin behavior for the various STOP modes follows:

- In STOP1 mode, all internal registers including general purpose I/O control and data registers are powered off. Each of the pins assumes its default reset state (input buffer, output buffer and internal pullup disabled). Upon exit from STOP1, all pins must be reconfigured the same as if the MCU had been reset.
- In STOP4 mode, all pin states are maintained because internal logic stays powered up. Upon recovery, all pin functions are the same as before entering STOP4.

6.3 General Purpose I/O Registers

This section provides information about the registers associated with the general purpose I/O ports and pin control functions. These general purpose I/O registers are located in page zero of the memory map and the pin control registers are located in the high page register section of memory.

6.4 Port A Registers

Port A general purpose I/O function is controlled by the registers described in this section.

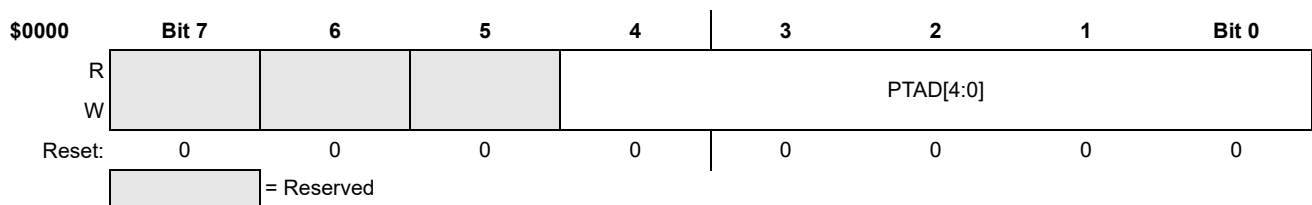

Figure 30. Port A Data Register (PTAD)

Table 33. Port A Data Register Field Descriptions

Field	Description
4:0 PTAD [4:0]	Port A Data Register Bit — For port A pins that are inputs, reads return the logic level on the pin. For port A pins that are configured as outputs, reads return the last value written to this register. Writes are latched into all bits of this register. For port A pins that are configured as outputs, the logic level is driven out the corresponding MCU pin. Reset forces PTAD to all 0s, but these 0s are not driven out the corresponding pins because reset also configures all port pins as high-impedance inputs with pullups disabled.

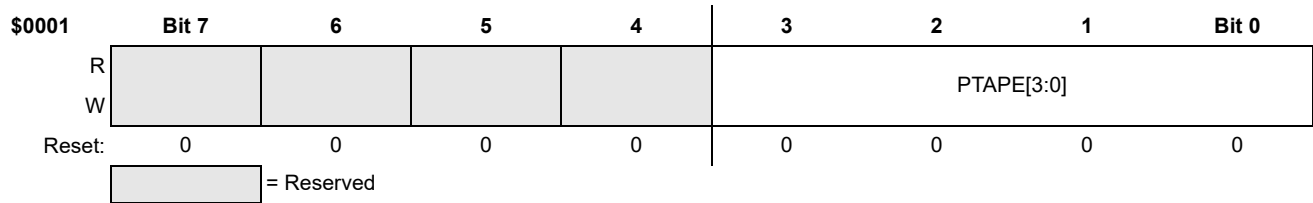

Figure 31. Internal Pullup Enable for Port A Register (PTAPE)

Table 34. Port A Register Pullup Enable Field Descriptions

Field	Description
3:0 PTAPE [3:0]	Internal Pullup Enable for Port A Bit n — Each of these control bits determines if the internal pullup device is enabled for the associated PTA pin. For port A pins that are configured as outputs, these bits have no effect and the internal pullup devices are disabled. 0 Internal pullup device disabled for port A bit n. 1 Internal pullup device enabled for port A bit n.

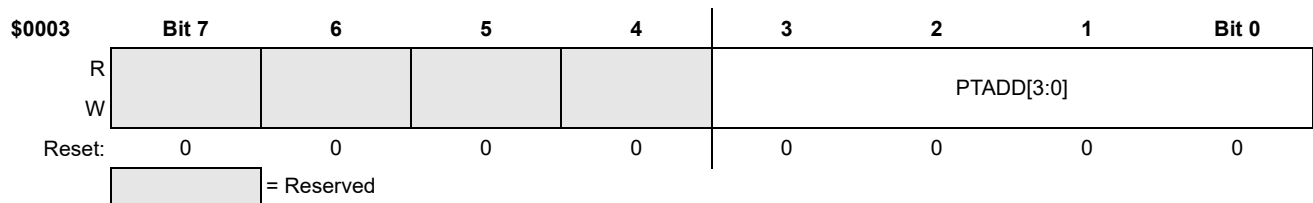

Figure 32. Data Direction for Port A Register (PTADD)

Table 35. Port A Data Direction Field Descriptions

Field	Description
3:0 PTADD [3:0]	Data Direction for Port A Bit n — These read/write bits control the direction of port A pins and what is read for PTADD reads. 0 Input (output driver disabled) and reads return the pin value. 1 Output driver enabled for port A bit n and PTADD reads return the contents of PTADDn. PTA4 is input-only, therefore bit 4 will always be 0.

6.5 Port B Registers

Port B PTB[1:0] functions are multiplexed with the LF receiver block such that the port B GPIOs become high impedance when the LF block has been enabled. When the LF block is disabled, port B pins operate as described here.

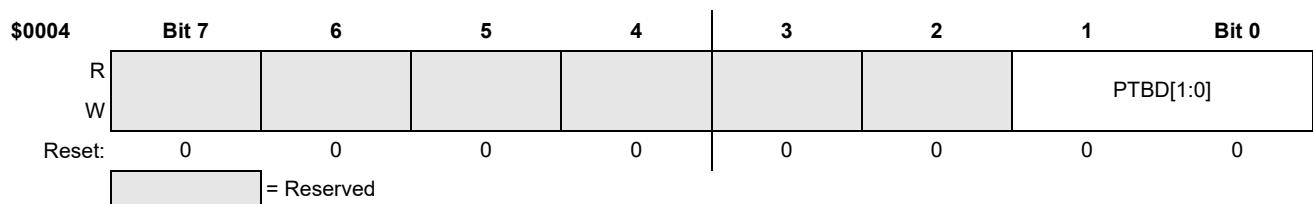

Figure 33. Port B Data Register (PTBD)

Table 36. Port B Data Register Field Descriptions

Field	Description
1:0 PTBD [1:0]	Port B Data Register Bit n — For port B pins that are inputs, reads return the logic level on the pin. For port B pins that are configured as outputs, reads return the last value written to this register. Writes are latched into all bits of this register. For port B pins that are configured as outputs, the logic level is driven out the corresponding MCU pin. Reset forces PTBD to all 0s, but these 0s are not driven out the corresponding pins because reset also configures all port pins as high-impedance inputs with pullups disabled.

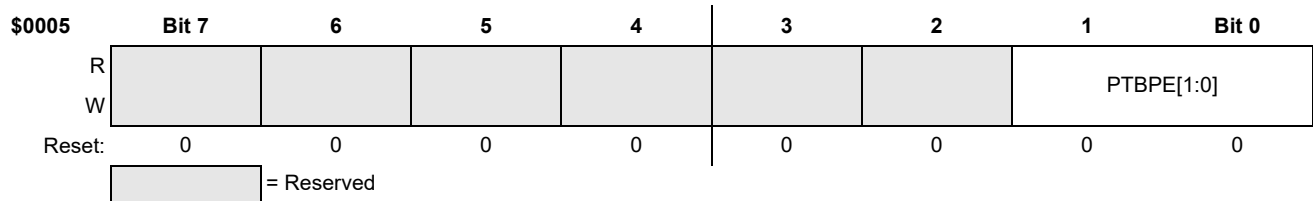

Figure 34. Internal Pullup Enable for Port B Register (PTBPE)

Table 37. Port B Register Pullup Enable Field Descriptions

Field	Description
1:0 PTBPE [1:0]	Internal Pullup Enable for Port B Bit n — Each of these control bits determines if the internal pullup device is enabled for the associated PTB pin. For port B pins that are configured as outputs, these bits have no effect and the internal pullup devices are disabled. 0 Internal pullup device disabled for port B bit n. 1 Internal pullup device enabled for port B bit n.

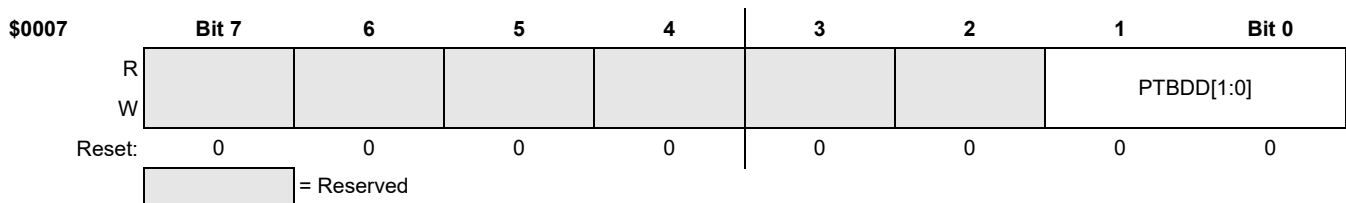

Figure 35. Data Direction for Port B Register (PTBDD)

Table 38. Port B Data Direction Field Descriptions

Field	Description
1:0 PTBDD [1:0]	Data Direction for Port B Bit n — These read/write bits control the direction of port B pins and what is read for PTBDD reads. 0 Input (output driver disabled) and reads return the pin value. 1 Output driver enabled for port B bit n and PTBDD reads return the contents of PTBDDn.

7 Keyboard Interrupt

The FXTH870x6 has a KBI module with general purpose I/O pins.

7.1 Features

The KBI features include:

- Up to four keyboard interrupt pins with individual pin enable bits.
- Each keyboard interrupt pin is programmable as falling edge (or rising edge) only, or both falling edge and low level (or both rising edge and high level) interrupt sensitivity.
- One software enabled keyboard interrupt.
- Exit from low-power modes.

7.2 Modes of Operation

This section defines the KBI operation in WAIT, STOP, and BACKGROUND DEBUG modes.

7.2.1 KBI in STOP Modes

The KBI operates asynchronously in STOP4 mode if enabled before executing the STOP instruction. Therefore, an enabled KBI pin (KBPE[3:0]) can be used to bring the MCU out of STOP4 mode if the KBI interrupt is enabled (KBIE = 1).

During STOP1 mode, the KBI is disabled. In some systems, the pins associated with the KBI may be sources of wakeup from STOP1, see the STOP modes section in the [Section 3](#). Upon wakeup from STOP1 mode, the KBI module will be in the reset state.

7.2.2 KBI in ACTIVE BACKGROUND mode

When the microcontroller is in ACTIVE BACKGROUND mode, the KBI will continue to operate normally.

7.3 Block Diagram

The block diagram for the keyboard interrupt module is shown [Figure 36](#).

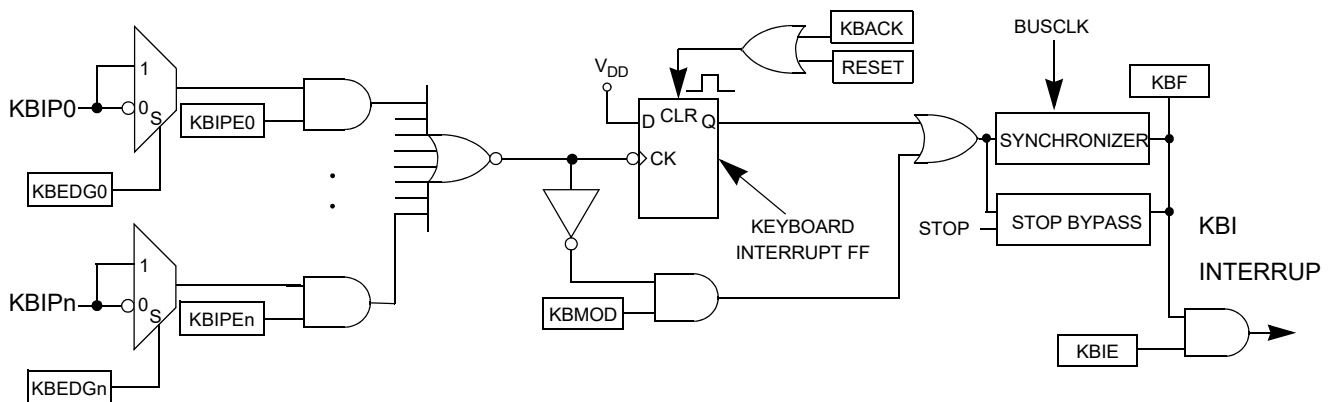

Figure 36. KBI Block Diagram

7.4 External Signal Description

The KBI input pins can be used to detect either falling edges, or both falling edge and low level interrupt requests. The KBI input pins can also be used to detect either rising edges, or both rising edge and high level interrupt requests. PTA[3:0] map to KBIPE and KBEDG function bits [3:0].

The signal properties of KBI are shown in [Table 39](#).

Table 39. Signal Properties

Signal	Function	I/O
KBIPn	Keyboard interrupt pins	I

7.5 Register Definitions

The KBI includes three registers:

- An 4-bit pin status and control register.
- An 4-bit pin enable register.
- An 4-bit edge select register.

7.5.1 KBI Status and Control Register (KBISC)

KBISC contains the status flag and control bits, which are used to configure the KBI.

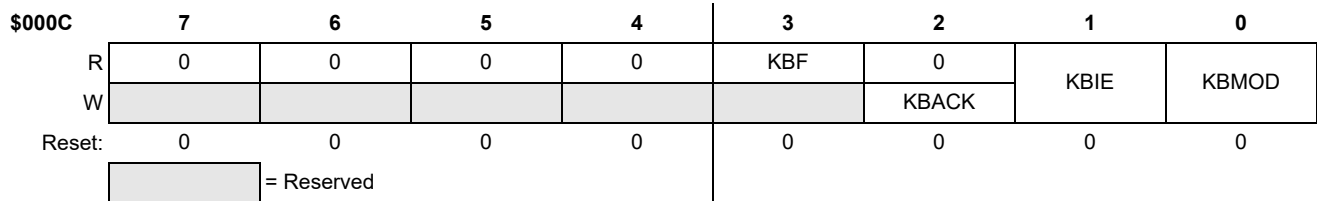

Figure 37. KBI Status and Control Register

Table 40. KBISC Register Field Descriptions

Field	Description
7:4	Unused register bits, always read 0.
3 KBF	Keyboard Interrupt Flag — KBF indicates when a keyboard interrupt is detected. Writes have no effect on KBF. 0 No keyboard interrupt detected. 1 Keyboard interrupt detected.
2 KBACK	Keyboard Acknowledge — Writing a 1 to KBACK is part of the flag clearing mechanism. KBACK always reads as 0.
1 KBIE	Keyboard Interrupt Enable — KBIE determines whether a keyboard interrupt is requested. 0 Keyboard interrupt request not enabled. 1 Keyboard interrupt request enabled.
0 KBMOD	Keyboard Detection Mode — KBMOD (along with the KBEDG bits) controls the detection mode of the keyboard interrupt pins. 0 Keyboard detects edges only. 1 Keyboard detects both edges and levels.

7.5.2 KBI Pin Enable Register (KBIPE)

KBIPE contains the pin enable control bits.

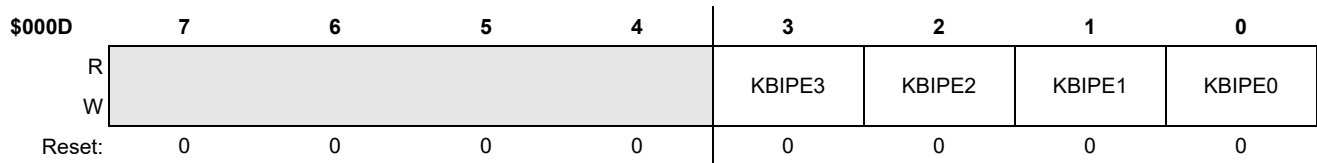

Figure 38. KBI Pin Enable Register

Table 41. KBIPE Register Field Descriptions

Field	Description
3:0 KBIPEn	Keyboard Pin Enables — Each of the KBIPEn bits enable the corresponding keyboard interrupt pin. 0 Pin not enabled as keyboard interrupt. 1 Pin enabled as keyboard interrupt.

7.5.3 KBI Edge Select Register (KBIES)

KBIES contains the edge select control bits.

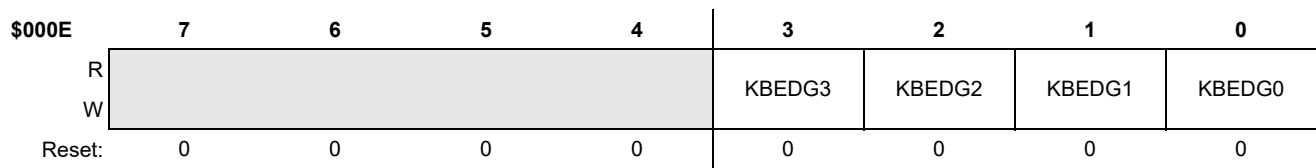

Figure 39. KBI Edge Select Register

Table 42. KBIES Register Field Descriptions

Field	Description
3:0 KBEDGn	<p>Keyboard Edge Selects — Each of the KBEDGn bits selects the falling edge/low level or rising edge/high level function of the corresponding pin).</p> <p>0 Falling edge/low level.</p> <p>1 Rising edge/high level.</p>

7.6 Functional Description

This on-chip peripheral module is called a keyboard interrupt (KBI) module because originally it was designed to simplify the connection and use of row-column matrices of keyboard switches. However, these inputs are also useful as extra external interrupt inputs and as an external means of waking the MCU from STOP or WAIT low-power modes.

The KBI module allows up to eight pins to act as additional interrupt sources. Writing to the KBIPE[3:0] bits in the keyboard interrupt pin enable register (KBIPE) independently enables or disables each KBI pin. Each KBI pin can be configured as edge sensitive or edge and level sensitive based on the KBMOD bit in the keyboard interrupt status and control register (KBISC). Edge sensitive can be software programmed to be either falling or rising; the level can be either low or high. The polarity of the edge or edge and level sensitivity is selected using the KBEDG[3:0] bits in the keyboard interrupt edge select register (KBIES).

Synchronous logic is used to detect edges. Prior to detecting an edge, enabled keyboard inputs must be at the reset logic level. A falling edge is detected when an enabled keyboard input signal is seen as a logic 1 (the reset level) during one bus cycle and then a logic 0 (the asserted level) during the next cycle. A rising edge is detected when the input signal is seen as a logic 0 during one bus cycle and then a logic 1 during the next cycle.

7.6.1 Edge Only Sensitivity

A valid edge on an enabled KBI pin will set KBF in KBISC. If KBIE in KBISC is set, an interrupt request will be presented to the CPU. Clearing of KBF is accomplished by writing a 1 to KBACK in KBISC.

7.6.2 Edge and Level Sensitivity

A valid edge or level on an enabled KBI pin will set KBF in KBISC. If KBIE in KBISC is set, an interrupt request will be presented to the CPU. Clearing of KBF is accomplished by writing a 1 to KBACK in KBISC provided all enabled keyboard inputs are at their reset levels. KBF will remain set if any enabled KBI pin is asserted while attempting to clear by writing a 1 to KBACK.

7.6.3 KBI Pullup/Pulldown Resistors

The KBI pins can be configured to use an internal pullup/pulldown resistor using the associated I/O port pullup enable register. If an internal resistor is enabled, the KBIES register is used to select whether the resistor is a pullup (KBEDG[3:0] = 0) or a pulldown (KBEDG[3:0] = 1).

7.6.4 KBI Initialization

When a keyboard interrupt pin is first enabled it is possible to get a false keyboard interrupt flag. To prevent a false interrupt request during keyboard initialization, the user should do the following:

1. Mask keyboard interrupts by clearing KBIE in KBISC.
2. Enable the KBI polarity by setting the appropriate KBEDGn bits in KBIES.
3. If using internal pullup/pulldown device, configure the associated pullup enable bits in PTAPE[3:0].
4. Enable the KBI pins by setting the appropriate KBIPE[3:0] bits in KBIPE.
5. Write to KBACK in KBISC to clear any false interrupts.
6. Set KBIE in KBISC to enable interrupts.

8 Central Processing Unit

8.1 Introduction

This section provides summary information about the registers, addressing modes, and instruction set of the CPU of the HCS08 Family. For a more detailed discussion, refer to the *HCS08 Family Reference Manual, volume 1*, NXP document order number HCS08RMV1/D.

The HCS08 CPU is fully source- and object-code-compatible with the M68HC08 CPU. Several instructions and enhanced addressing modes were added to improve C compiler efficiency and to support a new BACKGROUND DEBUG system which replaces the monitor mode of earlier M68HC08 microcontrollers (MCU).

8.2 Features

Features of the HCS08 CPU include:

- Object code fully upward-compatible with M68HC05 and M68HC08 Families
- All registers and memory are mapped to a single 64-Kbyte address space
- 16-bit stack pointer (any size stack anywhere in 64-Kbyte address space)
- 16-bit index register (H:X) with powerful indexed addressing modes
- 8-bit accumulator (A)
- Many instructions treat X as a second general-purpose 8-bit register
- Seven addressing modes:
 - Inherent — Operands in internal registers
 - Relative — 8-bit signed offset to branch destination
 - Immediate — Operand in next object code byte(s)
 - Direct — Operand in memory at 0x0000–0x00FF
 - Extended — Operand anywhere in 64-Kbyte address space
 - Indexed relative to H:X — Five submodes including auto-increment
 - Indexed relative to SP — Improves C efficiency dramatically
- Memory-to-memory data move instructions with four address mode combinations
- Overflow, half-carry, negative, zero, and carry condition codes support conditional branching on the results of signed, unsigned, and binary-coded decimal (BCD) operations
- Efficient bit manipulation instructions
- Fast 8-bit by 8-bit multiply and 16-bit by 8-bit divide instructions
- STOP and WAIT instructions to invoke low-power operating modes

8.3 Programmer's Model and CPU Registers

Figure 40 shows the five CPU registers. CPU registers are not part of the memory map.

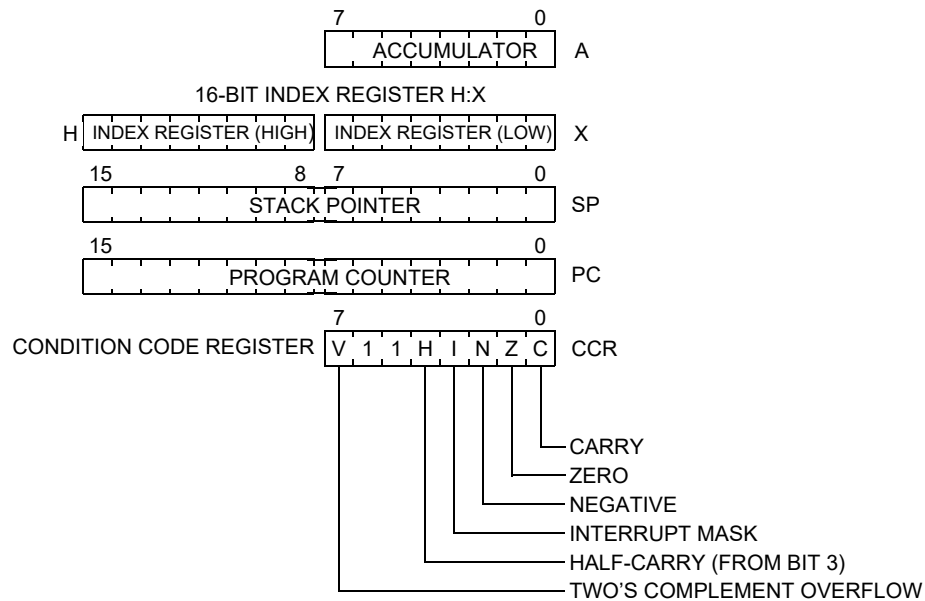

Figure 40. CPU Registers

8.3.1 Accumulator (A)

The A accumulator is a general-purpose 8-bit register. One operand input to the arithmetic logic unit (ALU) is connected to the accumulator and the ALU results are often stored into the A accumulator after arithmetic and logical operations. The accumulator can be loaded from memory using various addressing modes to specify the address where the loaded data comes from, or the contents of A can be stored to memory using various addressing modes to specify the address where data from A will be stored.

Reset has no effect on the contents of the A accumulator.

8.3.2 Index Register (H:X)

This 16-bit register is actually two separate 8-bit registers (H and X), which often work together as a 16-bit address pointer where H holds the upper byte of an address and X holds the lower byte of the address. All indexed addressing mode instructions use the full 16-bit value in H:X as an index reference pointer; however, for compatibility with the earlier M68HC05 Family, some instructions operate only on the low-order 8-bit half (X).

Many instructions treat X as a second general-purpose 8-bit register that can be used to hold 8-bit data values. X can be cleared, incremented, decremented, complemented, negated, shifted, or rotated. Transfer instructions allow data to be transferred from A or transferred to A where arithmetic and logical operations can then be performed.

For compatibility with the earlier M68HC05 Family, H is forced to 0x00 during reset. Reset has no effect on the contents of X.

8.3.3 Stack Pointer (SP)

This 16-bit address pointer register points at the next available location on the automatic last-in-first-out (LIFO) stack. The stack may be located anywhere in the 64-Kbyte address space that has RAM and can be any size up to the amount of available RAM. The stack is used to automatically save the return address for subroutine calls, the return address and CPU registers during interrupts, and for local variables. The AIS (add immediate to stack pointer) instruction adds an 8-bit signed immediate value to SP. This is most often used to allocate or deallocate space for local variables on the stack.

SP is forced to 0x00FF at reset for compatibility with the earlier M68HC05 Family. HCS08 programs normally change the value in SP to the address of the last location (highest address) in on-chip RAM during reset initialization to free up direct page RAM (from the end of the on-chip registers to 0x00FF).

The RSP (reset stack pointer) instruction was included for compatibility with the M68HC05 Family and is seldom used in new HCS08 programs because it only affects the low-order half of the stack pointer.

8.3.4 Program Counter (PC)

The program counter is a 16-bit register that contains the address of the next instruction or operand to be fetched.

During normal program execution, the program counter automatically increments to the next sequential memory location every time an instruction or operand is fetched. Jump, branch, interrupt, and return operations load the program counter with an address other than that of the next sequential location. This is called a change-of-flow.

During reset, the program counter is loaded with the reset vector that is located at 0xFFFFE and 0xFFFF. The vector stored there is the address of the first instruction that will be executed after exiting the reset state.

8.3.5 Condition Code Register (CCR)

The 8-bit condition code register contains the interrupt mask (I) and five flags that indicate the results of the instruction just executed. Bits 6 and 5 are set permanently to 1. The following paragraphs describe the functions of the condition code bits in general terms. For a more detailed explanation of how each instruction sets the CCR bits, refer to the *HCS08 Family Reference Manual, volume 1*, NXP document order number HCS08RMv1.

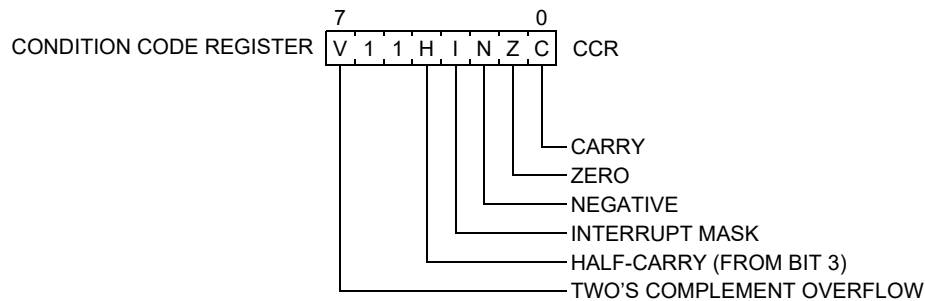

Figure 41. Condition Code Register

Table 43. CCR Register Field Descriptions

Field	Description
7 V	Two's Complement Overflow Flag — The CPU sets the overflow flag when a two's complement overflow occurs. The signed branch instructions BGT, BGE, BLE, and BLT use the overflow flag. 0 No overflow 1 Overflow
4 H	Half-Carry Flag — The CPU sets the half-carry flag when a carry occurs between accumulator bits 3 and 4 during an add-without-carry (ADD) or add-with-carry (ADC) operation. The half-carry flag is required for binary-coded decimal (BCD) arithmetic operations. The DAA instruction uses the states of the H and C condition code bits to automatically add a correction value to the result from a previous ADD or ADC on BCD operands to correct the result to a valid BCD value. 0 No carry between bits 3 and 4 1 Carry between bits 3 and 4
3 I	Interrupt Mask Bit — When the interrupt mask is set, all maskable CPU interrupts are disabled. CPU interrupts are enabled when the interrupt mask is cleared. When a CPU interrupt occurs, the interrupt mask is set automatically after the CPU registers are saved on the stack, but before the first instruction of the interrupt service routine is executed. Interrupts are not recognized at the instruction boundary after any instruction that clears I (CLI or TAP). This ensures that the next instruction after a CLI or TAP will always be executed without the possibility of an intervening interrupt, provided I was set. 0 Interrupts enabled 1 Interrupts disabled
2 N	Negative Flag — The CPU sets the negative flag when an arithmetic operation, logic operation, or data manipulation produces a negative result, setting bit 7 of the result. Simply loading or storing an 8-bit or 16-bit value causes N to be set if the most significant bit of the loaded or stored value was 1. 0 Non-negative result 1 Negative result
1 Z	Zero Flag — The CPU sets the zero flag when an arithmetic operation, logic operation, or data manipulation produces a result of 0x00 or 0x0000. Simply loading or storing an 8-bit or 16-bit value causes Z to be set if the loaded or stored value was all 0s. 0 Non-zero result 1 Zero result

Table 43. CCR Register Field Descriptions (continued)

Field	Description
0 C	Carry/Borrow Flag — The CPU sets the carry/borrow flag when an addition operation produces a carry out of bit 7 of the accumulator or when a subtraction operation requires a borrow. Some instructions — such as bit test and branch, shift, and rotate — also clear or set the carry/borrow flag.
0	No carry out of bit 7
1	Carry out of bit 7

8.4 Addressing Modes

Addressing modes define the way the CPU accesses operands and data. In the HCS08, all memory, status and control registers, and input/output (I/O) ports share a single 64-Kbyte linear address space so a 16-bit binary address can uniquely identify any memory location. This arrangement means that the same instructions that access variables in RAM can also be used to access I/O and control registers or nonvolatile program space.

Some instructions use more than one addressing mode. For instance, move instructions use one addressing mode to specify the source operand and a second addressing mode to specify the destination address. Instructions such as BRCLR, BRSET, CBEQ, and DBNZ use one addressing mode to specify the location of an operand for a test and then use relative addressing mode to specify the branch destination address when the tested condition is true. For BRCLR, BRSET, CBEQ, and DBNZ, the addressing mode listed in the instruction set tables is the addressing mode needed to access the operand to be tested, and relative addressing mode is implied for the branch destination.

8.4.1 Inherent Addressing Mode (INH)

In this addressing mode, operands needed to complete the instruction (if any) are located within CPU registers so the CPU does not need to access memory to get any operands.

8.4.2 Relative Addressing Mode (REL)

Relative addressing mode is used to specify the destination location for branch instructions. A signed 8-bit offset value is located in the memory location immediately following the opcode. During execution, if the branch condition is true, the signed offset is sign-extended to a 16-bit value and is added to the current contents of the program counter, which causes program execution to continue at the branch destination address.

8.4.3 Immediate Addressing Mode (IMM)

In immediate addressing mode, the operand needed to complete the instruction is included in the object code immediately following the instruction opcode in memory. In the case of a 16-bit immediate operand, the high-order byte is located in the next memory location after the opcode, and the low-order byte is located in the next memory location after that.

8.4.4 Direct Addressing Mode (DIR)

In direct addressing mode, the instruction includes the low-order eight bits of an address in the direct page (0x0000–0x00FF). During execution a 16-bit address is formed by concatenating an implied 0x00 for the high-order half of the address and the direct address from the instruction to get the 16-bit address where the desired operand is located. This is faster and more memory efficient than specifying a complete 16-bit address for the operand.

8.4.5 Extended Addressing Mode (EXT)

In extended addressing mode, the full 16-bit address of the operand is located in the next two bytes of program memory after the opcode (high byte first).

8.4.6 Indexed Addressing Mode

Indexed addressing mode has seven variations including five that use the 16-bit H:X index register pair and two that use the stack pointer as the base reference.

8.4.6.1 Indexed, No Offset (IX)

This variation of indexed addressing uses the 16-bit value in the H:X index register pair as the address of the operand needed to complete the instruction.

8.4.6.2 Indexed, No Offset with Post Increment (IX+)

This variation of indexed addressing uses the 16-bit value in the H:X index register pair as the address of the operand needed to complete the instruction. The index register pair is then incremented ($H:X = H:X + 0x0001$) after the operand has been fetched. This addressing mode is only used for MOV and CBEQ instructions.

8.4.6.3 Indexed, 8-Bit Offset (IX1)

This variation of indexed addressing uses the 16-bit value in the H:X index register pair plus an unsigned 8-bit offset included in the instruction as the address of the operand needed to complete the instruction.

8.4.6.4 Indexed, 8-Bit Offset with Post Increment (IX1+)

This variation of indexed addressing uses the 16-bit value in the H:X index register pair plus an unsigned 8-bit offset included in the instruction as the address of the operand needed to complete the instruction. The index register pair is then incremented ($H:X = H:X + 0x0001$) after the operand has been fetched. This addressing mode is used only for the CBEQ instruction.

8.4.6.5 Indexed, 16-Bit Offset (IX2)

This variation of indexed addressing uses the 16-bit value in the H:X index register pair plus a 16-bit offset included in the instruction as the address of the operand needed to complete the instruction.

8.4.6.6 SP-Relative, 8-Bit Offset (SP1)

This variation of indexed addressing uses the 16-bit value in the stack pointer (SP) plus an unsigned 8-bit offset included in the instruction as the address of the operand needed to complete the instruction.

8.4.6.7 SP-Relative, 16-Bit Offset (SP2)

This variation of indexed addressing uses the 16-bit value in the stack pointer (SP) plus a 16-bit offset included in the instruction as the address of the operand needed to complete the instruction.

8.5 Special Operations

The CPU performs a few special operations that are similar to instructions but do not have opcodes like other CPU instructions. In addition, a few instructions such as STOP and WAIT directly affect other MCU circuitry. This section provides additional information about these operations.

8.5.1 Reset Sequence

Reset can be caused by a power-on-reset (POR) event, internal conditions such as the COP (computer operating properly) watchdog, or by assertion of an external active-low reset pin. When a reset event occurs, the CPU immediately stops whatever it is doing (the MCU does not wait for an instruction boundary before responding to a reset event). For a more detailed discussion about how the MCU recognizes resets and determines the source, refer to [Section 5, "Reset, Interrupts and System Configuration"](#).

The reset event is considered concluded when the sequence to determine whether the reset came from an internal source is done and when the reset pin is no longer asserted. At the conclusion of a reset event, the CPU performs a 6-cycle sequence to fetch the reset vector from 0xFFFFE and 0xFFFF and to fill the instruction queue in preparation for execution of the first program instruction.

8.5.2 Interrupt Sequence

When an interrupt is requested, the CPU completes the current instruction before responding to the interrupt. At this point, the program counter is pointing at the start of the next instruction, which is where the CPU should return after servicing the interrupt. The CPU responds to an interrupt by performing the same sequence of operations as for a software interrupt (SWI) instruction, except the address used for the vector fetch is determined by the highest priority interrupt that is pending when the interrupt sequence started.

The CPU sequence for an interrupt is:

1. Store the contents of PCL, PCH, X, A, and CCR on the stack, in that order.
2. Set the I bit in the CCR.
3. Fetch the high-order half of the interrupt vector.
4. Fetch the low-order half of the interrupt vector.
5. Delay for one free bus cycle.
6. Fetch three bytes of program information starting at the address indicated by the interrupt vector to fill the instruction queue in preparation for execution of the first instruction in the interrupt service routine.

After the CCR contents are pushed onto the stack, the I bit in the CCR is set to prevent other interrupts while in the interrupt service routine. Although it is possible to clear the I bit with an instruction in the interrupt service routine, this would allow nesting of interrupts (which is not recommended because it leads to programs that are difficult to debug and maintain).

For compatibility with the earlier M68HC05 MCUs, the high-order half of the H:X index register pair (H) is not saved on the stack as part of the interrupt sequence. The user must use a PSHH instruction at the beginning of the service routine to save H and then use a PULH instruction just before the RTI that ends the interrupt service routine. It is not necessary to save H if you are

certain that the interrupt service routine does not use any instructions or auto-increment addressing modes that might change the value of H.

The software interrupt (SWI) instruction is like a hardware interrupt except that it is not masked by the global I bit in the CCR and it is associated with an instruction opcode within the program so it is not asynchronous to program execution.

8.5.3 WAIT Mode Operation

The WAIT instruction enables interrupts by clearing the I bit in the CCR. It then halts the clocks to the CPU to reduce overall power consumption while the CPU is waiting for the interrupt or reset event that will wake the CPU from WAIT mode. When an interrupt or reset event occurs, the CPU clocks will resume and the interrupt or reset event will be processed normally.

If a serial BACKGROUND command is issued to the MCU through the BACKGROUND DEBUG interface while the CPU is in WAIT mode, CPU clocks will resume and the CPU will enter ACTIVE BACKGROUND mode where other serial BACKGROUND commands can be processed. This ensures that a host development system can still gain access to a target MCU even if it is in WAIT mode.

8.5.4 STOP Mode Operation

Usually, all system clocks, including the crystal oscillator (when used), are halted during STOP mode to minimize power consumption. In such systems, external circuitry is needed to control the time spent in STOP mode and to issue a signal to wakeup the target MCU when it is time to resume processing. Unlike the earlier M68HC05 and M68HC08 MCUs, the HCS08 can be configured to keep a minimum set of clocks running in STOP mode. This optionally allows an internal periodic signal to wake the target MCU from STOP mode.

When a host debug system is connected to the BACKGROUND DEBUG pin (BKGD) and the ENBDM control bit has been set by a serial command through the BACKGROUND interface (or because the MCU was reset into ACTIVE BACKGROUND mode), the oscillator is forced to remain active when the MCU enters STOP mode. In this case, if a serial BACKGROUND command is issued to the MCU through the BACKGROUND DEBUG interface while the CPU is in STOP mode, CPU clocks will resume and the CPU will enter ACTIVE BACKGROUND mode where other serial BACKGROUND commands can be processed. This ensures that a host development system can still gain access to a target MCU even if it is in STOP mode.

Recovery from STOP mode depends on the particular HCS08 and whether the oscillator was stopped in STOP mode. Refer to the [Section 3](#) for more details.

8.5.5 BGND Instruction

The BGND instruction is new to the HCS08 compared to the M68HC08. BGND would not be used in normal user programs because it forces the CPU to stop processing user instructions and enter the ACTIVE BACKGROUND mode. The only way to resume execution of the user program is through reset or by a host debug system issuing a GO, TRACE1, or TAGGO serial command through the BACKGROUND DEBUG interface.

Software-based breakpoints can be set by replacing an opcode at the desired breakpoint address with the BGND opcode. When the program reaches this breakpoint address, the CPU is forced to ACTIVE BACKGROUND mode rather than continuing the user program.

8.6 HCS08 Instruction Set Summary

Instruction Set Summary Nomenclature

The nomenclature listed here is used in the instruction descriptions in [Table 44](#).

Operators

()	=	Contents of register or memory location shown inside parentheses
←	=	Is loaded with (read: "gets")
&	=	Boolean AND
	=	Boolean OR
⊕	=	Boolean exclusive-OR
×	=	Multiply
÷	=	Divide
:	=	Concatenate
+	=	Add
-	=	Negate (two's complement)

CPU registers

A	=	Accumulator
CCR	=	Condition code register
H	=	Index register, higher order (most significant) 8 bits

X	=	Index register, lower order (least significant) 8 bits
PC	=	Program counter
PCH	=	Program counter, higher order (most significant) 8 bits
PCL	=	Program counter, lower order (least significant) 8 bits
SP	=	Stack pointer

Memory and addressing

M	=	A memory location or absolute data, depending on addressing mode
M:M + 0x0001	=	A 16-bit value in two consecutive memory locations. The higher-order (most significant) 8 bits are located at the address of M, and the lower-order (least significant) 8 bits are located at the next higher sequential address.

Condition code register (CCR) bits

V	=	Two's complement overflow indicator, bit 7
H	=	Half carry, bit 4
I	=	Interrupt mask, bit 3
N	=	Negative indicator, bit 2
Z	=	Zero indicator, bit 1
C	=	Carry/borrow, bit 0 (carry out of bit 7)

CCR activity notation

–	=	Bit not affected
0	=	Bit forced to 0
1	=	Bit forced to 1
P	=	Bit set or cleared according to results of operation
U	=	Undefined after the operation

Machine coding notation

dd	=	Low-order 8 bits of a direct address 0x0000–0x00FF (high byte assumed to be 0x00)
ee	=	Upper 8 bits of 16-bit offset
ff	=	Lower 8 bits of 16-bit offset or 8-bit offset
ii	=	One byte of immediate data
jj	=	High-order byte of a 16-bit immediate data value
kk	=	Low-order byte of a 16-bit immediate data value
hh	=	High-order byte of 16-bit extended address
ll	=	Low-order byte of 16-bit extended address
rr	=	Relative offset

Source form

Everything in the source forms columns, *except expressions in italic characters*, is literal information that must appear in the assembly source file exactly as shown. The initial 3- to 5-letter mnemonic is always a literal expression. All commas, pound signs (#), parentheses, and plus signs (+) are literal characters.

<i>n</i>	—	Any label or expression that evaluates to a single integer in the range 0–7
<i>opr8i</i>	—	Any label or expression that evaluates to an 8-bit immediate value
<i>opr16i</i>	—	Any label or expression that evaluates to a 16-bit immediate value
<i>opr8a</i>	—	Any label or expression that evaluates to an 8-bit value. The instruction treats this 8-bit value as the low order 8 bits of an address in the direct page of the 64-Kbyte address space (0x00xx).
<i>opr16a</i>	—	Any label or expression that evaluates to a 16-bit value. The instruction treats this value as an address in the 64-Kbyte address space.
<i>oprx8</i>	—	Any label or expression that evaluates to an unsigned 8-bit value, used for indexed addressing
<i>oprx16</i>	—	Any label or expression that evaluates to a 16-bit value. Because the HCS08 has a 16-bit address bus, this can be either a signed or an unsigned value.
<i>rel</i>	—	Any label or expression that refers to an address that is within –128 to +127 locations from the next address after the last byte of object code for the current instruction. The assembler will calculate the 8-bit signed offset and include it in the object code for this instruction.

Address modes

INH	=	Inherent (no operands)
IMM	=	8-bit or 16-bit immediate
DIR	=	8-bit direct
EXT	=	16-bit extended
IX	=	16-bit indexed no offset
IX+	=	16-bit indexed no offset, post increment (CBEQ and MOV only)
IX1	=	16-bit indexed with 8-bit offset from H:X
IX1+	=	16-bit indexed with 8-bit offset, post increment (CBEQ only)
IX2	=	16-bit indexed with 16-bit offset from H:X
REL	=	8-bit relative offset
SP1	=	Stack pointer with 8-bit offset
SP2	=	Stack pointer with 16-bit offset

Table 44. HCS08 Instruction Set Summary (Sheet 1 of 8)

Source Form	Operation	Description	Effect on CCR						Address Mode	Opcode	Operand	Bus Cycles ⁽¹⁾
			V	H	I	N	Z	C				
ADC #opr8i ADC opr8a ADC opr16a ADC oprx16,X ADC oprx8,X ADC ,X ADC oprx16,SP ADC oprx8,SP	Add with Carry	$A \leftarrow (A) + (M) + (C)$	p	p	-	p	p	p	IMM DIR EXT IX2 IX1 IX SP2 SP1	A9 ii B9 dd C9 hh ll D9 ee ff E9 ff F9 9ED9 ee ff 9EE9 ff	2 3 4 4 3 3 5 4	
ADD #opr8i ADD opr8a ADD opr16a ADD oprx16,X ADD oprx8,X ADD ,X ADD oprx16,SP ADD oprx8,SP	Add without Carry	$A \leftarrow (A) + (M)$	p	p	-	p	p	p	IMM DIR EXT IX2 IX1 IX SP2 SP1	AB ii BB dd CB hh ll DB ee ff EB ff FB 9EDB ee ff 9EEB ff	2 3 4 4 3 3 5 4	
AIS #opr8i	Add Immediate Value (Signed) to Stack Pointer	$SP \leftarrow (SP) + (M)$ M is sign extended to a 16-bit value	-	-	-	-	-	-	IMM	A7 ii	2	
AIX #opr8i	Add Immediate Value (Signed) to Index Register (H:X)	$H:X \leftarrow (H:X) + (M)$ M is sign extended to a 16-bit value	-	-	-	-	-	-	IMM	AF ii	2	
AND #opr8i AND opr8a AND opr16a AND oprx16,X AND oprx8,X AND ,X AND oprx16,SP AND oprx8,SP	Logical AND	$A \leftarrow (A) \& (M)$	0	-	-	p	p	-	IMM DIR EXT IX2 IX1 IX SP2 SP1	A4 ii B4 dd C4 hh ll D4 ee ff E4 ff F4 9ED4 ee ff 9EE4 ff	2 3 4 4 3 3 5 4	
ASL opr8a ASLA ASLX ASL oprx8,X ASL ,X ASL oprx8,SP	Arithmetic Shift Left (Same as LSL)		p	-	-	p	p	p	DIR INH INH IX1 IX SP1	38 dd 48 58 68 ff 78 9E68 ff	5 1 1 5 4 6	

Table 44. HCS08 Instruction Set Summary (Sheet 2 of 8)

Source Form	Operation	Description	Effect on CCR						Address Mode	Opcode	Operand	Bus Cycles ⁽¹⁾
			V	H	I	N	Z	C				
ASR <i>opr8a</i> ASRA ASRX ASR <i>opr8,X</i> ASR <i>,X</i> ASR <i>opr8,SP</i>	Arithmetic Shift Right		▯	-	-	▯	▯	▯	DIR INH IX1 IX SP1	37 47 57 67 77 9E67	dd dd ff ff ff	5 1 1 5 4 6
BCC <i>rel</i>	Branch if Carry Bit Clear	Branch if (C) = 0	-	-	-	-	-	-	REL	24	rr	3
BCLR <i>n,opr8a</i>	Clear Bit n in Memory	$M_n \leftarrow 0$	-	-	-	-	-	-	DIR (b0) DIR (b1) DIR (b2) DIR (b3) DIR (b4) DIR (b5) DIR (b6) DIR (b7)	11 13 15 17 19 1B 1D 1F	dd dd dd dd dd dd dd dd	5 5 5 5 5 5 5 5
BCS <i>rel</i>	Branch if Carry Bit Set (Same as BLO)	Branch if (C) = 1	-	-	-	-	-	-	REL	25	rr	3
BEQ <i>rel</i>	Branch if Equal	Branch if (Z) = 1	-	-	-	-	-	-	REL	27	rr	3
BGE <i>rel</i>	Branch if Greater Than or Equal To (Signed Operands)	Branch if $(N \oplus V) = 0$	-	-	-	-	-	-	REL	90	rr	3
BGND	Enter ACTIVE BACK- GROUND if ENBDM = 1	Waits For and Processes BDM Commands Until GO, TRACE1, or TAGGO	-	-	-	-	-	-	INH	82		5+
BGT <i>rel</i>	Branch if Greater Than (Signed Operands)	Branch if $(Z) (N \oplus V) = 0$	-	-	-	-	-	-	REL	92	rr	3
BHCC <i>rel</i>	Branch if Half Carry Bit Clear	Branch if (H) = 0	-	-	-	-	-	-	REL	28	rr	3
BHCS <i>rel</i>	Branch if Half Carry Bit Set	Branch if (H) = 1	-	-	-	-	-	-	REL	29	rr	3
BHI <i>rel</i>	Branch if Higher	Branch if $(C) (Z) = 0$	-	-	-	-	-	-	REL	22	rr	3
BHS <i>rel</i>	Branch if Higher or Same (Same as BCC)	Branch if (C) = 0	-	-	-	-	-	-	REL	24	rr	3
BIH <i>rel</i>	Branch if IRQ Pin High	Branch if IRQ pin = 1	-	-	-	-	-	-	REL	2F	rr	3
BIL <i>rel</i>	Branch if IRQ Pin Low	Branch if IRQ pin = 0	-	-	-	-	-	-	REL	2E	rr	3
BIT <i>#opr8i</i> BIT <i>opr8a</i> BIT <i>opr16a</i> BIT <i>opr16,X</i> BIT <i>opr8,X</i> BIT <i>,X</i> BIT <i>opr16,SP</i> BIT <i>opr8,SP</i>	Bit Test	(A) & (M) (CCR Updated but Operands Not Changed)	0	-	-	▯	▯	-	IMM DIR EXT IX2 IX1 IX SP2 SP1	A5 B5 C5 D5 E5 F5 9ED5 9EE5	ii dd hh ll ee ff ff ff ee ff ff	2 3 4 4 3 3 5 4
BLE <i>rel</i>	Branch if Less Than or Equal To (Signed Operands)	Branch if $(Z) (N \oplus V) = 1$	-	-	-	-	-	-	REL	93	rr	3
BLO <i>rel</i>	Branch if Lower (Same as BCS)	Branch if (C) = 1	-	-	-	-	-	-	REL	25	rr	3
BLS <i>rel</i>	Branch if Lower or Same	Branch if $(C) (Z) = 1$	-	-	-	-	-	-	REL	23	rr	3
BLT <i>rel</i>	Branch if Less Than (Signed Operands)	Branch if $(N \oplus V) = 1$	-	-	-	-	-	-	REL	91	rr	3
BMC <i>rel</i>	Branch if Interrupt Mask Clear	Branch if (I) = 0	-	-	-	-	-	-	REL	2C	rr	3

Table 44. HCS08 Instruction Set Summary (Sheet 3 of 8)

Source Form	Operation	Description	Effect on CCR						Address Mode	Opcode	Operand	Bus Cycles ⁽¹⁾
			V	H	I	N	Z	C				
BMI <i>rel</i>	Branch if Minus	Branch if (N) = 1	–	–	–	–	–	–	REL	2B	rr	3
BMS <i>rel</i>	Branch if Interrupt Mask Set	Branch if (I) = 1	–	–	–	–	–	–	REL	2D	rr	3
BNE <i>rel</i>	Branch if Not Equal	Branch if (Z) = 0	–	–	–	–	–	–	REL	26	rr	3
BPL <i>rel</i>	Branch if Plus	Branch if (N) = 0	–	–	–	–	–	–	REL	2A	rr	3
BRA <i>rel</i>	Branch Always	No Test	–	–	–	–	–	–	REL	20	rr	3
BRCLR <i>n,opr8a,rel</i>	Branch if Bit <i>n</i> in Memory Clear	Branch if (Mn) = 0	–	–	–	–	–	p	DIR (b0)	01	dd rr	5
									DIR (b1)	03	dd rr	5
									DIR (b2)	05	dd rr	5
									DIR (b3)	07	dd rr	5
									DIR (b4)	09	dd rr	5
									DIR (b5)	0B	dd rr	5
									DIR (b6)	0D	dd rr	5
DIR (b7)	0F	dd rr	5									
BRN <i>rel</i>	Branch Never	Uses 3 Bus Cycles	–	–	–	–	–	–	REL	21	rr	3
BRSET <i>n,opr8a,rel</i>	Branch if Bit <i>n</i> in Memory Set	Branch if (Mn) = 1	–	–	–	–	–	p	DIR (b0)	00	dd rr	5
									DIR (b1)	02	dd rr	5
									DIR (b2)	04	dd rr	5
									DIR (b3)	06	dd rr	5
									DIR (b4)	08	dd rr	5
									DIR (b5)	0A	dd rr	5
									DIR (b6)	0C	dd rr	5
DIR (b7)	0E	dd rr	5									
BSET <i>n,opr8a</i>	Set Bit <i>n</i> in Memory	Mn ← 1	–	–	–	–	–	–	DIR (b0)	10	dd	5
									DIR (b1)	12	dd	5
									DIR (b2)	14	dd	5
									DIR (b3)	16	dd	5
									DIR (b4)	18	dd	5
									DIR (b5)	1A	dd	5
									DIR (b6)	1C	dd	5
DIR (b7)	1E	dd	5									
BSR <i>rel</i>	Branch to Subroutine	PC ← (PC) + 0x0002 push (PCL); SP ← (SP) – 0x0001 push (PCH); SP ← (SP) – 0x0001 PC ← (PC) + <i>rel</i>	–	–	–	–	–	–	REL	AD	rr	5
CBEQ <i>opr8a,rel</i> CBEQA # <i>opr8i,rel</i> CBEQX # <i>opr8i,rel</i> CBEQ <i>opr8,X+,rel</i> CBEQ <i>,X+,rel</i> CBEQ <i>opr8,SP,rel</i>	Compare and Branch if Equal	Branch if (A) = (M)	–	–	–	–	–	–	DIR	31	dd rr	5
		Branch if (A) = (M)							IMM	41	ii rr	4
		Branch if (X) = (M)							IMM	51	ii rr	4
		Branch if (A) = (M)							IX1+	61	ff rr	5
		Branch if (A) = (M)							IX+	71	rr ff	5
		Branch if (A) = (M)							SP1	9E61	rr	6
CLC	Clear Carry Bit	C ← 0	–	–	–	–	–	0	INH	98		1
CLI	Clear Interrupt Mask Bit	I ← 0	–	–	0	–	–	–	INH	9A		1
CLR <i>opr8a</i> CLRA CLR X CLR H CLR <i>opr8,X</i> CLR <i>,X</i> CLR <i>opr8,SP</i>	Clear	M ← 0x00	0	–	–	0	1	–	DIR	3F	dd	5
		A ← 0x00							INH	4F		1
		X ← 0x00							INH	5F		1
		H ← 0x00							INH	8C		1
		M ← 0x00							IX1	6F	ff	5
		M ← 0x00							IX	7F		4
		M ← 0x00							SP1	9E6F	ff	6

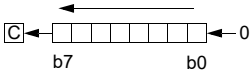
Table 44. HCS08 Instruction Set Summary (Sheet 4 of 8)

Source Form	Operation	Description	Effect on CCR						Address Mode	Opcode	Operand	Bus Cycles ⁽¹⁾
			V	H	I	N	Z	C				
CMP #opr8i CMP opr8a CMP opr16a CMP oprx16,X CMP oprx8,X CMP ,X CMP oprx16,SP CMP oprx8,SP	Compare Accumulator with Memory	(A) – (M) (CCR Updated But Operands Not Changed)	▯	–	–	▯	▯	▯	IMM DIR EXT IX2 IX1 IX SP2 SP1	A1 B1 C1 D1 E1 F1 9ED1 9EE1	ii dd hh ll ee ff ff ff ee ff ff	2 3 4 4 3 3 5 4
COM opr8a COMA COMX COM oprx8,X COM ,X COM oprx8,SP	Complement (One's Complement)	$M \leftarrow (\overline{M}) = 0xFF - (M)$ $A \leftarrow (\overline{A}) = 0xFF - (A)$ $X \leftarrow (\overline{X}) = 0xFF - (X)$ $M \leftarrow (\overline{M}) = 0xFF - (M)$ $M \leftarrow (\overline{M}) = 0xFF - (M)$ $M \leftarrow (\overline{M}) = 0xFF - (M)$	0	–	–	▯	▯	1	DIR INH INH IX1 IX SP1	33 43 53 63 73 9E63	dd hh ll ff ff ff ff	5 1 1 5 4 6
CPHX opr16a CPHX #opr16i CPHX opr8a CPHX oprx8,SP	Compare Index Register (H:X) with Memory	(H:X) – (M:M + 0x0001) (CCR Updated But Operands Not Changed)	▯	–	–	▯	▯	▯	EXT IMM DIR SP1	3E 65 75 9EF3	hh ll jj kk dd ff	6 3 5 6
CPX #opr8i CPX opr8a CPX opr16a CPX oprx16,X CPX oprx8,X CPX ,X CPX oprx16,SP CPX oprx8,SP	Compare X (Index Register Low) with Memory	(X) – (M) (CCR Updated But Operands Not Changed)	▯	–	–	▯	▯	▯	IMM DIR EXT IX2 IX1 IX SP2 SP1	A3 B3 C3 D3 E3 F3 9ED3 9EE3	ii dd hh ll ee ff ff ff ee ff ff	2 3 4 4 3 3 5 4
DAA	Decimal Adjust Accumulator After ADD or ADC of BCD Values	(A) ₁₀	U	–	–	▯	▯	▯	INH	72		1
DBNZ opr8a,rel DBNZA rel DBNZX rel DBNZ oprx8,X,rel DBNZ ,X,rel DBNZ oprx8,SP,rel	Decrement and Branch if Not Zero	Decrement A, X, or M Branch if (result) ≠ 0 DBNZX Affects X Not H	–	–	–	–	–	–	DIR INH INH IX1 IX SP1	3B 4B 5B 6B 7B 9E6B	dd rr rr rr ff rr rr ff rr	7 4 4 7 6 8
DEC opr8a DECA DECX DEC oprx8,X DEC ,X DEC oprx8,SP	Decrement	$M \leftarrow (M) - 0x01$ $A \leftarrow (A) - 0x01$ $X \leftarrow (X) - 0x01$ $M \leftarrow (M) - 0x01$ $M \leftarrow (M) - 0x01$ $M \leftarrow (M) - 0x01$	▯	–	–	▯	▯	–	DIR INH INH IX1 IX SP1	3A 4A 5A 6A 7A 9E6A	dd dd dd ff ff ff	5 1 1 5 4 6
DIV	Divide	$A \leftarrow (H:A) \div (X)$ H ← Remainder	–	–	–	–	▯	▯	INH	52		6
EOR #opr8i EOR opr8a EOR opr16a EOR oprx16,X EOR oprx8,X EOR ,X EOR oprx16,SP EOR oprx8,SP	Exclusive OR Memory with Accumulator	$A \leftarrow (A \oplus M)$	0	–	–	▯	▯	–	IMM DIR EXT IX2 IX1 IX SP2 SP1	A8 B8 C8 D8 E8 F8 9ED8 9EE8	ii dd hh ll ee ff ff ff ee ff ff	2 3 4 4 3 3 5 4
INC opr8a INCA INCX INC oprx8,X INC ,X INC oprx8,SP	Increment	$M \leftarrow (M) + 0x01$ $A \leftarrow (A) + 0x01$ $X \leftarrow (X) + 0x01$ $M \leftarrow (M) + 0x01$ $M \leftarrow (M) + 0x01$ $M \leftarrow (M) + 0x01$	▯	–	–	▯	▯	–	DIR INH INH IX1 IX SP1	3C 4C 5C 6C 7C 9E6C	dd dd ff ff ff ff	5 1 1 5 4 6

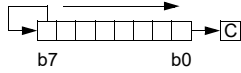
Table 44. HCS08 Instruction Set Summary (Sheet 5 of 8)

Source Form	Operation	Description	Effect on CCR						Address Mode	Opcode	Operand	Bus Cycles ⁽¹⁾
			V	H	I	N	Z	C				
JMP <i>opr8a</i> JMP <i>opr16a</i> JMP <i>opr16,X</i> JMP <i>opr8,X</i> JMP <i>,X</i>	Jump	PC ← Jump Address	–	–	–	–	–	–	DIR EXT IX2 IX1 IX	BC dd CC hh ll DC ee ff EC ff FC	3 4 4 3 3	
JSR <i>opr8a</i> JSR <i>opr16a</i> JSR <i>opr16,X</i> JSR <i>opr8,X</i> JSR <i>,X</i>	Jump to Subroutine	PC ← (PC) + <i>n</i> (<i>n</i> = 1, 2, or 3) Push (PCL); SP ← (SP) – 0x0001 Push (PCH); SP ← (SP) – 0x0001 PC ← Unconditional Address	–	–	–	–	–	–	DIR EXT IX2 IX1 IX	BD dd CD hh ll DD ee ff ED ff FD	5 6 6 5 5	
LDA <i>#opr8i</i> LDA <i>opr8a</i> LDA <i>opr16a</i> LDA <i>opr16,X</i> LDA <i>opr8,X</i> LDA <i>,X</i> LDA <i>opr16,SP</i> LDA <i>opr8,SP</i>	Load Accumulator from Memory	A ← (M)	0	–	–	▯	▯	–	IMM DIR EXT IX2 IX1 IX SP2 SP1	A6 ii B6 dd C6 hh ll D6 ee ff E6 ff F6 9ED6 ee ff 9EE6 ff	2 3 4 4 3 3 5 4	
LDHX <i>#opr16i</i> LDHX <i>opr8a</i> LDHX <i>opr16a</i> LDHX <i>,X</i> LDHX <i>opr16,X</i> LDHX <i>opr8,X</i> LDHX <i>opr8,SP</i>	Load Index Register (H:X) from Memory	H:X ← (M:M + 0x0001)	0	–	–	▯	▯	–	IMM DIR EXT IX IX2 IX1 SP1	45 jj kk 55 dd 32 hh ll 9EAE 9EBE ee ff 9ECE ff 9EFE ff	3 4 5 5 6 5 5	
LDX <i>#opr8i</i> LDX <i>opr8a</i> LDX <i>opr16a</i> LDX <i>opr16,X</i> LDX <i>opr8,X</i> LDX <i>,X</i> LDX <i>opr16,SP</i> LDX <i>opr8,SP</i>	Load X (Index Register Low) from Memory	X ← (M)	0	–	–	▯	▯	–	IMM DIR EXT IX2 IX1 IX SP2 SP1	AE ii BE dd CE hh ll DE ee ff EE ff FE 9EDE ee ff 9EEE ff	2 3 4 4 3 3 5 4	
LSL <i>opr8a</i> LSLA LSLX LSL <i>opr8,X</i> LSL <i>,X</i> LSL <i>opr8,SP</i>	Logical Shift Left (Same as ASL)		▯	–	–	▯	▯	▯	DIR INH INH IX1 IX SP1	38 dd 48 58 68 ff 78 9E68 ff	5 1 1 5 4 6	
LSR <i>opr8a</i> LSRA LSRX LSR <i>opr8,X</i> LSR <i>,X</i> LSR <i>opr8,SP</i>	Logical Shift Right		▯	–	–	0	▯	▯	DIR INH INH IX IX SP1	34 dd 44 54 64 ff 74 9E64 ff	5 1 1 5 4 6	
MOV <i>opr8a,opr8a</i> MOV <i>opr8a,X+</i> MOV <i>#opr8i,opr8a</i> MOV <i>,X+,opr8a</i>	Move	(M) _{destination} ← (M) _{source} H:X ← (H:X) + 0x0001 in IX+/DIR and DIR/IX+ Modes	0	–	–	▯	▯	–	DIR/DIR DIR/IX+ IMM/DIR IX+/DIR	4E dd dd 5E dd 6E ii dd 7E dd	5 5 4 5	
MUL	Unsigned multiply	X:A ← (X) × (A)	–	0	–	–	–	0	INH	42	5	
NEG <i>opr8a</i> NEGA NEGX NEG <i>opr8,X</i> NEG <i>,X</i> NEG <i>opr8,SP</i>	Negate (Two's Complement)	M ← – (M) = 0x00 – (M) A ← – (A) = 0x00 – (A) X ← – (X) = 0x00 – (X) M ← – (M) = 0x00 – (M) M ← – (M) = 0x00 – (M) M ← – (M) = 0x00 – (M)	▯	–	–	▯	▯	▯	DIR INH INH IX1 IX SP1	30 dd 40 50 60 ff 70 9E60 ff	5 1 1 5 4 6	
NOP	No Operation	Uses 1 Bus Cycle	–	–	–	–	–	–	INH	9D	1	

Table 44. HCS08 Instruction Set Summary (Sheet 6 of 8)

Source Form	Operation	Description	Effect on CCR						Address Mode	Opcode	Operand	Bus Cycles ⁽¹⁾
			V	H	I	N	Z	C				
NSA	Nibble Swap Accumulator	$A \leftarrow (A[3:0]:A[7:4])$	-	-	-	-	-	-	INH	62		1
ORA #opr8i ORA opr8a ORA opr16a ORA oprx16,X ORA oprx8,X ORA ,X ORA oprx16,SP ORA oprx8,SP	Inclusive OR Accumulator and Memory	$A \leftarrow (A) (M)$	0	-	-	▯	▯	-	IMM DIR EXT IX2 IX1 IX SP2 SP1	AA ii BA dd CA hh ll DA ee ff EA ff FA 9EDA ee ff 9EEA ff		2 3 4 4 3 3 5 4
PSHA	Push Accumulator onto Stack	Push (A); $SP \leftarrow (SP) - 0x0001$	-	-	-	-	-	-	INH	87		2
PSHH	Push H (Index Register High) onto Stack	Push (H); $SP \leftarrow (SP) - 0x0001$	-	-	-	-	-	-	INH	8B		2
PSHX	Push X (Index Register Low) onto Stack	Push (X); $SP \leftarrow (SP) - 0x0001$	-	-	-	-	-	-	INH	89		2
PULA	Pull Accumulator from Stack	$SP \leftarrow (SP + 0x0001)$; Pull (A)	-	-	-	-	-	-	INH	86		3
PULH	Pull H (Index Register High) from Stack	$SP \leftarrow (SP + 0x0001)$; Pull (H)	-	-	-	-	-	-	INH	8A		3
PULX	Pull X (Index Register Low) from Stack	$SP \leftarrow (SP + 0x0001)$; Pull (X)	-	-	-	-	-	-	INH	88		3
ROL opr8a ROLA ROLX ROL oprx8,X ROL ,X ROL oprx8,SP	Rotate Left through Carry		▯	-	-	▯	▯	▯	DIR INH INH IX1 IX SP1	39 dd 49 59 69 ff 79 9E69 ff		5 1 1 5 4 6
ROR opr8a RORA RORX ROR oprx8,X ROR ,X ROR oprx8,SP	Rotate Right through Carry		▯	-	-	▯	▯	▯	DIR INH INH IX1 IX SP1	36 dd 46 56 66 ff 76 9E66 ff		5 1 1 5 4 6
RSP	Reset Stack Pointer	$SP \leftarrow 0xFF$ (High Byte Not Affected)	-	-	-	-	-	-	INH	9C		1
RTI	Return from Interrupt	$SP \leftarrow (SP) + 0x0001$; Pull (CCR) $SP \leftarrow (SP) + 0x0001$; Pull (A) $SP \leftarrow (SP) + 0x0001$; Pull (X) $SP \leftarrow (SP) + 0x0001$; Pull (PCH) $SP \leftarrow (SP) + 0x0001$; Pull (PCL)	▯	▯	▯	▯	▯	▯	INH	80		9
RTS	Return from Subroutine	$SP \leftarrow SP + 0x0001$; Pull (PCH) $SP \leftarrow SP + 0x0001$; Pull (PCL)	-	-	-	-	-	-	INH	81		6
SBC #opr8i SBC opr8a SBC opr16a SBC oprx16,X SBC oprx8,X SBC ,X SBC oprx16,SP SBC oprx8,SP	Subtract with Carry	$A \leftarrow (A) - (M) - (C)$	▯	-	-	▯	▯	▯	IMM DIR EXT IX2 IX1 IX SP2 SP1	A2 ii B2 dd C2 hh ll D2 ee ff E2 ff F2 9ED2 ee ff 9EE2 ff		2 3 4 4 3 3 5 4
SEC	Set Carry Bit	$C \leftarrow 1$	-	-	-	-	-	1	INH	99		1
SEI	Set Interrupt Mask Bit	$I \leftarrow 1$	-	-	1	-	-	-	INH	9B		1

Table 44. HCS08 Instruction Set Summary (Sheet 7 of 8)

Source Form	Operation	Description	Effect on CCR						Address Mode	Opcode	Operand	Bus Cycles ⁽¹⁾
			V	H	I	N	Z	C				
STA <i>opr8a</i> STA <i>opr16a</i> STA <i>opr16,X</i> STA <i>opr8,X</i> STA <i>,X</i> STA <i>opr16,SP</i> STA <i>opr8,SP</i>	Store Accumulator in Memory	$M \leftarrow (A)$	0	-	-	p	p	-	DIR EXT IX2 IX1 IX SP2 SP1	B7 dd C7 hh ll D7 ee ff E7 ff F7 9ED7 ee ff 9EE7 ff	3 4 4 3 2 5 4	
STHX <i>opr8a</i> STHX <i>opr16a</i> STHX <i>opr8,SP</i>	Store H:X (Index Reg.)	$(M:M + 0x0001) \leftarrow (H:X)$	0	-	-	p	p	-	DIR EXT SP1	35 dd 96 hh ll 9EFF ff	4 5 5	
STOP	Enable Interrupts: Stop Processing Refer to MCU Documenta- tion	I bit \leftarrow 0; Stop Processing	-	-	0	-	-	-	INH	8E	2+	
STX <i>opr8a</i> STX <i>opr16a</i> STX <i>opr16,X</i> STX <i>opr8,X</i> STX <i>,X</i> STX <i>opr16,SP</i> STX <i>opr8,SP</i>	Store X (Low 8 Bits of Index Register) in Memory	$M \leftarrow (X)$	0	-	-	p	p	-	DIR EXT IX2 IX1 IX SP2 SP1	BF dd CF hh ll DF ee ff EF ff FF 9EDF ee ff 9EEF ff	3 4 4 3 2 5 4	
SUB <i>#opr8i</i> SUB <i>opr8a</i> SUB <i>opr16a</i> SUB <i>opr16,X</i> SUB <i>opr8,X</i> SUB <i>,X</i> SUB <i>opr16,SP</i> SUB <i>opr8,SP</i>	Subtract	$A \leftarrow (A) - (M)$	p	-	-	p	p	p	IMM DIR EXT IX2 IX1 IX SP2 SP1	A0 ii B0 dd C0 hh ll D0 ee ff E0 ff F0 9ED0 ee ff 9EE0 ff	2 3 4 4 3 3 5 4	
SWI	Software Interrupt	PC \leftarrow (PC) + 0x0001 Push (PCL); SP \leftarrow (SP) - 0x0001 Push (PCH); SP \leftarrow (SP) - 0x0001 Push (X); SP \leftarrow (SP) - 0x0001 Push (A); SP \leftarrow (SP) - 0x0001 Push (CCR); SP \leftarrow (SP) - 0x0001 I \leftarrow 1; PCH \leftarrow Interrupt Vector High Byte PCL \leftarrow Interrupt Vector Low Byte	-	-	1	-	-	-	INH	83	11	
TAP	Transfer Accumulator to CCR	$CCR \leftarrow (A)$	p	p	p	p	p	p	INH	84	1	
TAX	Transfer Accumulator to X (Index Register Low)	$X \leftarrow (A)$	-	-	-	-	-	-	INH	97	1	
TPA	Transfer CCR to Accu- mulator	$A \leftarrow (CCR)$	-	-	-	-	-	-	INH	85	1	
TST <i>opr8a</i> TSTA TSTX TST <i>opr8,X</i> TST <i>,X</i> TST <i>opr8,SP</i>	Test for Negative or Zero	(M) - 0x00 (A) - 0x00 (X) - 0x00 (M) - 0x00 (M) - 0x00 (M) - 0x00	0	-	-	p	p	-	DIR INH INH IX1 IX SP1	3D dd 4D 5D 6D ff 7D 9E6D ff	4 1 1 4 3 5	
TSX	Transfer SP to Index Reg.	$H:X \leftarrow (SP) + 0x0001$	-	-	-	-	-	-	INH	95	2	
TXA	Transfer X (Index Reg. Low) to Accumulator	$A \leftarrow (X)$	-	-	-	-	-	-	INH	9F	1	
TXS	Transfer Index Reg. to SP	$SP \leftarrow (H:X) - 0x0001$	-	-	-	-	-	-	INH	94	2	

Table 44. HCS08 Instruction Set Summary (Sheet 8 of 8)

Source Form	Operation	Description	Effect on CCR						Address Mode	Opcode	Operand	Bus Cycles ⁽¹⁾
			V	H	I	N	Z	C				
WAIT	Enable Interrupts; Wait for Interrupt	I bit ← 0; Halt CPU	–	–	0	–	–	–	INH	8F		2+

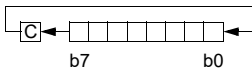
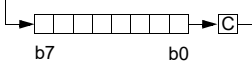
1. Bus clock frequency is one-half of the CPU clock frequency.

Table 45. Opcode Map (Sheet 1 of 2)

Bit-Manipulation		Branch		Read-Modify-Write				Control				Register/Memory					
00 5 BRSET0 3 DIR	10 5 BSET0 2 DIR	20 3 BRA 2 REL	30 5 NEG 2 DIR	40 1 NEGA 1 INH	50 1 NEGX 1 INH	60 5 NEG 2 IX1	70 4 NEG 1 IX	80 9 RTI 1 INH	90 3 BGE 2 REL	A0 2 SUB 2 IMM	B0 3 SUB 2 DIR	C0 4 SUB 3 EXT	D0 4 SUB 3 IX2	E0 3 SUB 2 IX1	F0 3 SUB 1 IX		
01 5 BRCLR0 3 DIR	11 5 BCLR0 2 DIR	21 3 BRN 2 REL	31 5 CBEQ 3 DIR	41 4 CBEQA 3 IMM	51 4 CBEQX 3 IMM	61 5 CBEQ 3 IX1+	71 5 CBEQ 2 IX+	81 6 RTS 1 INH	91 3 BLT 2 REL	A1 2 CMP 2 IMM	B1 3 CMP 2 DIR	C1 4 CMP 3 EXT	D1 4 CMP 3 IX2	E1 3 CMP 2 IX1	F1 3 CMP 1 IX		
02 5 BRSET1 3 DIR	12 5 BSET1 2 DIR	22 3 BHI 2 REL	32 5 LDHX 3 EXT	42 5 MUL 1 INH	52 6 DIV 1 INH	62 1 NSA 1 INH	72 1 DAA 1 INH	82 5+ BGND 1 INH	92 3 BGT 2 REL	A2 2 SBC 2 IMM	B2 3 SBC 2 DIR	C2 4 SBC 3 EXT	D2 4 SBC 3 IX2	E2 3 SBC 2 IX1	F2 3 SBC 1 IX		
03 5 BRCLR1 3 DIR	13 5 BCLR1 2 DIR	23 3 BLS 2 REL	33 5 COM 2 DIR	43 1 COMA 1 INH	53 1 COMX 1 INH	63 5 COM 2 IX1	73 4 COM 1 IX	83 11 SWI 1 INH	93 3 BLE 2 REL	A3 2 CPX 2 IMM	B3 3 CPX 2 DIR	C3 4 CPX 3 EXT	D3 4 CPX 3 IX2	E3 3 CPX 2 IX1	F3 3 CPX 1 IX		
04 5 BRCLR2 3 DIR	14 5 BSET2 2 DIR	24 3 BCC 2 REL	34 5 LSR 2 DIR	44 1 LSRA 1 INH	54 1 LSRX 1 INH	64 5 LSR 2 IX1	74 4 LSR 1 IX	84 1 TAP 1 INH	94 2 TXS 1 INH	A4 2 AND 2 IMM	B4 3 AND 2 DIR	C4 4 AND 3 EXT	D4 4 AND 3 IX2	E4 3 AND 2 IX1	F4 3 AND 1 IX		
05 5 BRCLR2 3 DIR	15 5 BCLR2 2 DIR	25 3 BCS 2 REL	35 4 STHX 2 DIR	45 3 LDHX 3 IMM	55 4 LDHX 2 DIR	65 3 CPHX 3 IMM	75 5 CPHX 2 DIR	85 1 TPA 1 INH	95 2 TSX 1 INH	A5 2 BIT 2 IMM	B5 3 BIT 2 DIR	C5 4 BIT 3 EXT	D5 4 BIT 3 IX2	E5 3 BIT 2 IX1	F5 3 BIT 1 IX		
06 5 BRSET3 3 DIR	16 5 BSET3 2 DIR	26 3 BNE 2 REL	36 5 ROR 2 DIR	46 1 RORA 1 INH	56 1 RORX 1 INH	66 5 ROR 2 IX1	76 4 ROR 1 IX	86 3 PULA 1 INH	96 5 STHX 3 EXT	A6 2 LDA 2 IMM	B6 3 LDA 2 DIR	C6 4 LDA 3 EXT	D6 4 LDA 3 IX2	E6 3 LDA 2 IX1	F6 3 LDA 1 IX		
07 5 BRCLR3 3 DIR	17 5 BCLR3 2 DIR	27 3 BEQ 2 REL	37 5 ASR 2 DIR	47 1 ASRA 1 INH	57 1 ASRX 1 INH	67 5 ASR 2 IX1	77 4 ASR 1 IX	87 2 PSHA 1 INH	97 1 TAX 1 INH	A7 2 AIS 2 IMM	B7 3 STA 2 DIR	C7 4 STA 3 EXT	D7 4 STA 3 IX2	E7 3 STA 2 IX1	F7 2 STA 1 IX		
08 5 BRSET4 3 DIR	18 5 BSET4 2 DIR	28 3 BHCC 2 REL	38 5 LSL 2 DIR	48 1 LSLA 1 INH	58 1 LSLX 1 INH	68 5 LSL 2 IX1	78 4 LSL 1 IX	88 3 PULX 1 INH	98 1 CLC 1 INH	A8 2 EOR 2 IMM	B8 3 EOR 2 DIR	C8 4 EOR 3 EXT	D8 4 EOR 3 IX2	E8 3 EOR 2 IX1	F8 3 EOR 1 IX		
09 5 BRCLR4 3 DIR	19 5 BCLR4 2 DIR	29 3 BHCS 2 REL	39 5 ROL 2 DIR	49 1 ROLA 1 INH	59 1 ROLX 1 INH	69 5 ROL 2 IX1	79 4 ROL 1 IX	89 2 PSHX 1 INH	99 1 SEC 1 INH	A9 2 ADC 2 IMM	B9 3 ADC 2 DIR	C9 4 ADC 3 EXT	D9 4 ADC 3 IX2	E9 3 ADC 2 IX1	F9 3 ADC 1 IX		
0A 5 BRSET5 3 DIR	1A 5 BSET5 2 DIR	2A 3 BPL 2 REL	3A 5 DEC 2 DIR	4A 1 DECA 1 INH	5A 1 DECX 1 INH	6A 5 DEC 2 IX1	7A 4 DEC 1 IX	8A 3 PULH 1 INH	9A 1 CLI 1 INH	AA 2 ORA 2 IMM	BA 3 ORA 2 DIR	CA 4 ORA 3 EXT	DA 4 ORA 3 IX2	EA 3 ORA 2 IX1	FA 3 ORA 1 IX		
0B 5 BRCLR5 3 DIR	1B 5 BCLR5 2 DIR	2B 3 BMI 2 REL	3B 7 DBNZ 3 DIR	4B 4 DBNZA 2 INH	5B 4 DBNZX 2 INH	6B 7 DBNZ 3 IX1	7B 6 DBNZ 2 IX	8B 2 PSHH 1 INH	9B 1 SEI 1 INH	AB 2 ADD 2 IMM	BB 3 ADD 2 DIR	CB 4 ADD 3 EXT	DB 4 ADD 3 IX2	EB 3 ADD 2 IX1	FB 3 ADD 1 IX		
0C 5 BRSET6 3 DIR	1C 5 BSET6 2 DIR	2C 3 BMC 2 REL	3C 5 INC 2 DIR	4C 1 INCA 1 INH	5C 1 INCX 1 INH	6C 5 INC 2 IX1	7C 4 INC 1 IX	8C 1 CLRH 1 INH	9C 1 RSP 1 INH		BC 3 JMP 2 DIR	CC 4 JMP 3 EXT	DC 4 JMP 3 IX2	EC 3 JMP 2 IX1	FC 3 JMP 1 IX		
0D 5 BRCLR6 3 DIR	1D 5 BCLR6 2 DIR	2D 3 BMS 2 REL	3D 4 TST 2 DIR	4D 1 TSTA 1 INH	5D 1 TSTX 1 INH	6D 4 TST 2 IX1	7D 3 TST 1 IX		9D 1 NOP 1 INH	AD 5 BSR 2 REL	BD 5 JSR 2 DIR	CD 6 JSR 3 EXT	DD 6 JSR 3 IX2	ED 5 JSR 2 IX1	FD 5 JSR 1 IX		
0E 5 BRSET7 3 DIR	1E 5 BSET7 2 DIR	2E 3 BIL 2 REL	3E 6 CPHX 3 EXT	4E 5 MOV 3 DD	5E 5 MOV 2 DIX+	6E 4 MOV 3 IMD	7E 5 MOV 2 IX+D	8E 2+ STOP 1 INH	9E Page 2	AE 2 LDX 2 IMM	BE 3 LDX 2 DIR	CE 4 LDX 3 EXT	DE 4 LDX 3 IX2	EE 3 LDX 2 IX1	FE 3 LDX 1 IX		
0F 5 BRCLR7 3 DIR	1F 5 BCLR7 2 DIR	2F 3 BIH 2 REL	3F 5 CLR 2 DIR	4F 1 CLRA 1 INH	5F 1 CLR 1 INH	6F 5 CLR 2 IX1	7F 4 CLR 1 IX	8F 2+ WAIT 1 INH	9F 1 TXA 1 INH	AF 2 AIX 2 IMM	BF 3 STX 2 DIR	CF 4 STX 3 EXT	DF 4 STX 3 IX2	EF 3 STX 2 IX1	FF 2 STX 1 IX		

INH Inherent
 IMM Immediate
 DIR Direct
 EXT Extended
 DD DIR to DIR
 IX+D IX+ to DIR
 REL Relative
 IX Indexed, No Offset
 IX1 Indexed, 8-Bit Offset
 IX2 Indexed, 16-Bit Offset
 IMD IMM to DIR
 DIX+ DIR to IX+
 SP1 Stack Pointer, 8-Bit Offset
 SP2 Stack Pointer, 16-Bit Offset
 IX+ Indexed, No Offset with Post Increment
 IX1+ Indexed, 1-Byte Offset with Post Increment

Opcode in Hexadecimal
 Number of Bytes

F0	3	HCS08 Cycles
SUB	IX	Instruction Mnemonic
1		Addressing Mode

Table 45. Opcode Map (Sheet 2 of 2)

Bit-Manipulation		Branch	Read-Modify-Write			Control			Register/Memory						
						9E60 6 NEG 3 SP1							9ED0 5 SUB 4 SP2	9EE0 4 SUB 3 SP1	
						9E61 6 CBEQ 4 SP1							9ED1 5 CMP 4 SP2	9EE1 4 CMP 3 SP1	
													9ED2 5 SBC 4 SP2	9EE2 4 SBC 3 SP1	
						9E63 6 COM 3 SP1							9ED3 5 CPX 4 SP2	9EE3 4 CPX 3 SP1	9EF3 6 CPHX 3 SP1
						9E64 6 LSR 3 SP1							9ED4 5 AND 4 SP2	9EE4 4 AND 3 SP1	
													9ED5 5 BIT 4 SP2	9EE5 4 BIT 3 SP1	
						9E66 6 ROR 3 SP1							9ED6 5 LDA 4 SP2	9EE6 4 LDA 3 SP1	
						9E67 6 ASR 3 SP1							9ED7 5 STA 4 SP2	9EE7 4 STA 3 SP1	
						9E68 6 LSL 3 SP1							9ED8 5 EOR 4 SP2	9EE8 4 EOR 3 SP1	
						9E69 6 ROL 3 SP1							9ED9 5 ADC 4 SP2	9EE9 4 ADC 3 SP1	
						9E6A 6 DEC 3 SP1							9EDA 5 ORA 4 SP2	9EEA 4 ORA 3 SP1	
						9E6B 8 DBNZ 4 SP1							9EDB 5 ADD 4 SP2	9EEB 4 ADD 3 SP1	
						9E6C 6 INC 3 SP1									
						9E6D 5 TST 3 SP1									
										9EAE 5 LDHX 2 IX	9EBE 6 LDHX 4 IX2	9ECE 5 LDHX 3 IX1	9EDE 5 LDX 4 SP2	9EEE 4 LDX 3 SP1	9EFE 5 LDHX 3 SP1
						9E6F 6 CLR 3 SP1							9EDF 5 STX 4 SP2	9EEF 4 STX 3 SP1	9EFF 5 STHX 3 SP1

INH Inherent
 IMM Immediate
 DIR Direct
 EXT Extended
 DD DIR to DIR
 IX+D IX+ to DIR
 REL Relative
 IX Indexed, No Offset
 IX1 Indexed, 8-Bit Offset
 IX2 Indexed, 16-Bit Offset
 IMD IMM to DIR
 DIX+ DIR to IX+
 SP1 Stack Pointer, 8-Bit Offset
 SP2 Stack Pointer, 16-Bit Offset
 IX+ Indexed, No Offset with Post Increment
 IX1+ Indexed, 1-Byte Offset with Post Increment

Note: All Sheet 2 Opcodes are Preceded by the Page 2 Prebyte (9E)

Prebyte (9E) and Opcode in Hexadecimal	9E60 6 NEG 3 SP1	HCS08 Cycles Instruction Mnemonic Addressing Mode
Number of Bytes		

9 Timer Pulse-Width Module

The timer pulse-width module (TPM1) is a two channel timer system that supports traditional input capture, output compare, or edge-aligned PWM on each channel. All the features and functions of the TPM1 are as described in the MC9S08RC16 product specification. The user has the option to connect the two timer channels to the PTA[3:2] pins, if those pins are not needed for an LFR channel or other general purpose I/O function. The following clock source and frequency selections are available using the system option register 2 as shown in [Figure 23](#) and [Table 27](#).

In addition one channel of the TPM1 can be connected to a 500 kHz clock (D_X) derived from the crystal oscillator on the RFM. This selection is made by setting the TPM1 to use an external clock. This clock source allows time calibration of the LFO as described in the [Section 14](#).

9.1 Features

The TPM1 has the following features:

- May be configured for buffered, center-aligned pulse-width modulation (CPWM) on all channels
- Clock sources independently selectable
- Selectable clock sources (device dependent): bus clock, fixed system clock
- Clock prescaler taps for divide by 1, 2, 4, 8, 16, 32, 64, or 128
- 16-bit free-running or up/down (CPWM) count operation
- 16-bit modulus register to control counter range
- Timer system enable
- One interrupt per channel plus a terminal count interrupt
- Channel features:
 - Each channel may be input capture, output compare, or buffered edge-aligned PWM
 - Rising-edge, falling-edge, or any-edge input capture trigger
 - Set, clear, or toggle output compare action
 - Selectable polarity on PWM outputs

9.2 TPM1 Configuration Information

The device provides one two-channel timer/pulse-width modulator (TPM1).

An easy way to measure the low frequency oscillator (LFO) is to connect the LFO directly to TPM1 channel 0. The LFOSEL bit in the SOPTZ determines whether TPM1CH0 is connected to PTAZ or the LFO.

TPM1 clock source selection for the TPM1 is shown in the table below.

Table 46. TPM1 Clock Source Selection

CLKSB	CLKSA	Clock Source
0	0	No source; TPM1 disabled
0	1	BUSCLK
1	0	unused
1	1	Internal DX pin

9.2.1 Block Diagram

Figure 42 shows the structure of a TPM1.

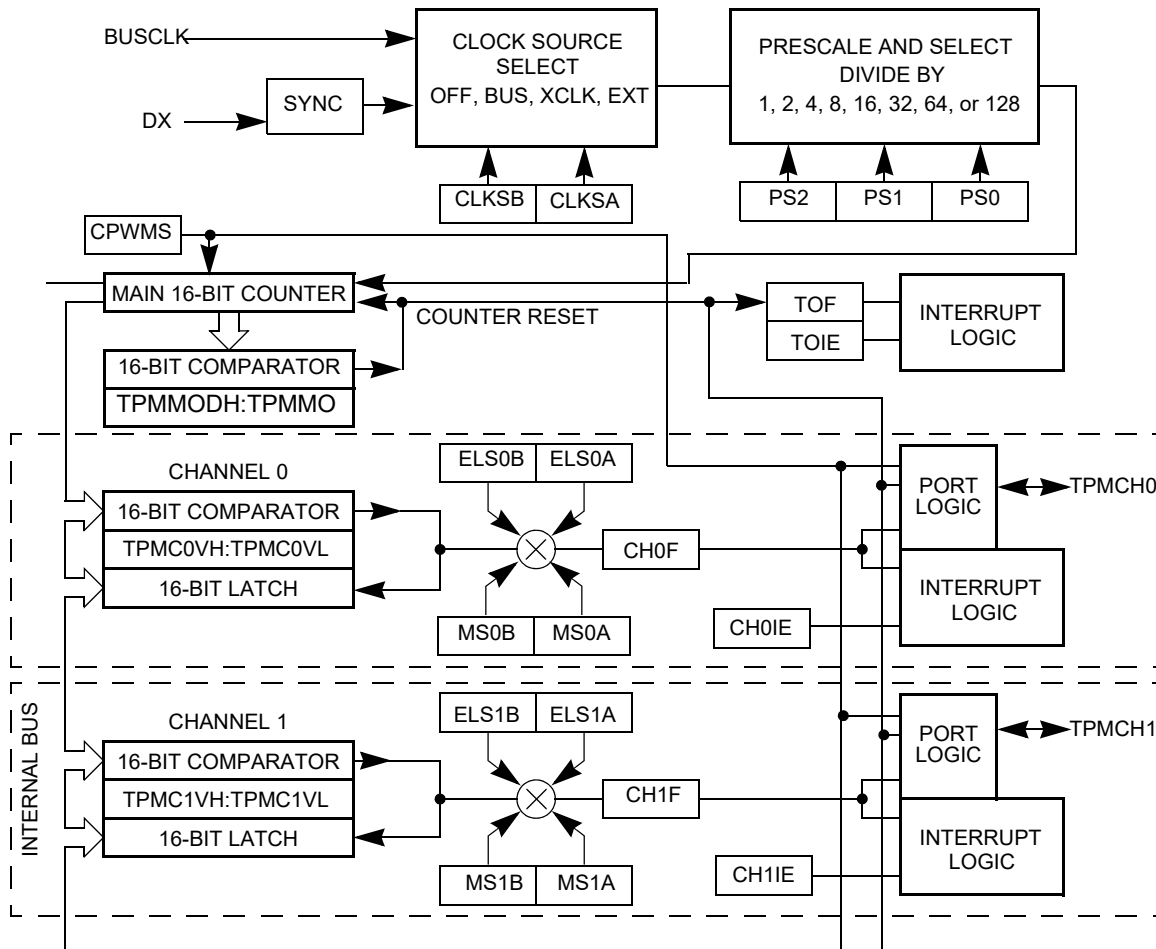

Figure 42. TPM1 Block Diagram

The central component of the TPM1 is the 16-bit counter that can operate as a free-running counter, a modulo counter, or an up/down-counter when the TPM1 is configured for center-aligned PWM. The TPM1 counter (when operating in normal up-counting mode) provides the timing reference for the input capture, output compare, and edge-aligned PWM functions. The timer counter modulo registers, TPMMODH:TPMMODL, control the modulo value of the counter. (The values 0x0000 or 0xFFFF effectively make the counter free running.) Software can read the counter value at any time without affecting the counting sequence. Any write to either byte of the TPMCNT counter resets the counter regardless of the data value written.

All TPM1 channels are programmable independently as input capture, output compare, or buffered edge-aligned PWM channels.

9.3 External Signal Description

When any pin associated with the timer is configured as a timer input, a passive pullup can be enabled. After reset, the TPM1 modules are disabled and all pins default to general-purpose inputs with the passive pullups disabled.

Each TPM1 channel is associated with an I/O pin on the MCU. The function of this pin depends on the configuration of the channel. In some cases, no pin function is needed so the pin reverts to being controlled by general-purpose I/O controls. When a timer has control of a port pin, the port data and data direction registers do not affect the related pin(s). See the [Section 2](#) for additional information about shared pin functions.

9.4 Register Definition

The TPM1 includes:

- An 8-bit status and control register (TPMSC)
- A 16-bit counter (TPMCNTH:TPMCNTL)
- A 16-bit modulo register (TPMMODH:TPMMODL)

Each timer channel has:

- An 8-bit status and control register (TPMCnSC)
- A 16-bit channel value register (TPMCnVH:TPMCnVL)

9.4.1 Timer Status and Control Register (TPM1SC)

TPM1SC contains the overflow status flag and control bits that are used to configure the interrupt enable, TPM1 configuration, clock source, and prescale divisor. These controls relate to all channels within this timer module.

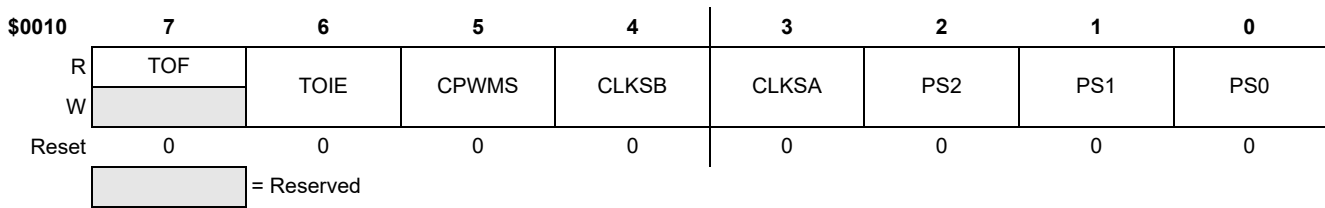

Figure 43. Timer Status and Control Register (TPM1SC)

Table 47. TPM1SC Register Field Descriptions

Field	Description
7 TOF	Timer Overflow Flag — This flag is set when the TPM1 counter changes to 0x0000 after reaching the modulo value programmed in the TPM1 counter modulo registers. When the TPM1 is configured for CPWM, TOF is set after the counter has reached the value in the modulo register, at the transition to the next lower count value. Clear TOF by reading the TPM1 status and control register when TOF is set and then writing a 0 to TOF. If another TPM1 overflow occurs before the clearing sequence is complete, the sequence is reset so TOF would remain set after the clear sequence was completed for the earlier TOF. Reset clears TOF. Writing a 1 to TOF has no effect. 0 TPM1 counter has not reached modulo value or overflow 1 TPM1 counter has overflowed
6 TOIE	Timer Overflow Interrupt Enable — This read/write bit enables TPM1 overflow interrupts. If TOIE is set, an interrupt is generated when TOF equals 1. Reset clears TOIE. 0 TOF interrupts inhibited (use software polling) 1 TOF interrupts enabled
5 CPWMS	Center-Aligned PWM Select — This read/write bit selects CPWM operating mode. Reset clears this bit so the TPM1 operates in up-counting mode for input capture, output compare, and edge-aligned PWM functions. Setting CPWMS reconfigures the TPM1 to operate in up-/down-counting mode for CPWM functions. Reset clears CPWMS. 0 All TPM channels operate as input capture, output compare, or edge-aligned PWM mode as selected by the MSnB:MSnA control bits in each channel's status and control register 1 All TPM channels operate in center-aligned PWM mode
4:3 CLKS[B:A]	Clock Source Select — As shown in Table 46, this 2-bit field is used to disable the TPM1 system or select one of three clock sources to drive the counter prescaler. The internal DX source is synchronized to the bus clock by an on-chip synchronization circuit.
2:0 PS[2:0]	Prescale Divisor Select — This 3-bit field selects one of eight divisors for the TPM1 clock input as shown in Table 48. This prescaler is located after any clock source synchronization or clock source selection, so it affects whatever clock source is selected to drive the TPM1 system.

Table 48. Prescale Divisor Selection

PS2:PS1:PS0	TPM1 Clock Source Divided-By
0:0:0	1
0:0:1	2
0:1:0	4
0:1:1	8
1:0:0	16
1:0:1	32
1:1:0	64
1:1:1	128

9.4.2 Timer Counter Registers (TPM1CNTH:TPM1CNTL)

The two read-only TPM1 counter registers contain the high and low bytes of the value in the TPM1 counter. Reading either byte (TPM1CNTH or TPM1CNTL) latches the contents of both bytes into a buffer where they remain latched until the other byte is read. This allows coherent 16-bit reads in either order. The coherency mechanism is automatically restarted by an MCU reset, a write of any value to TPM1CNTH or TPM1CNTL, or any write to the timer status/control register (TPM1SC).

Reset clears the TPM1 counter registers.

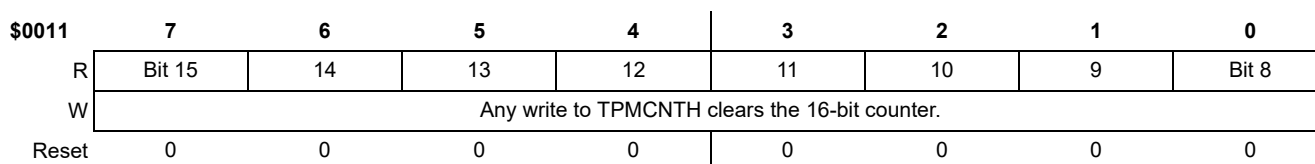

Figure 44. Timer Counter Register High (TPM1CNTH)

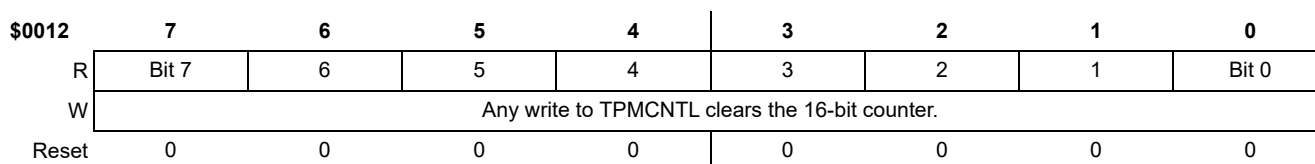

Figure 45. Timer Counter Register Low (TPM1CNTL)

When BACKGROUND mode is active, the timer counter and the coherency mechanism are frozen such that the buffer latches remain in the state they were in when the BACKGROUND mode became active even if one or both bytes of the counter are read while BACKGROUND mode is active.

9.4.3 Timer Counter Modulo Registers (TPM1MODH:TPM1MODL)

The read/write TPM1 modulo registers contain the modulo value for the TPM1 counter. After the TPM1 counter reaches the modulo value, the TPM1 counter resumes counting from 0x0000 at the next clock (CPWMS = 0) or starts counting down (CPWMS = 1), and the overflow flag (TOF) becomes set. Writing to TPM1MODH or TPM1MODL inhibits TOF and overflow interrupts until the other byte is written. Reset sets the TPM1 counter modulo registers to 0x0000, which results in a free-running timer counter (modulo disabled).

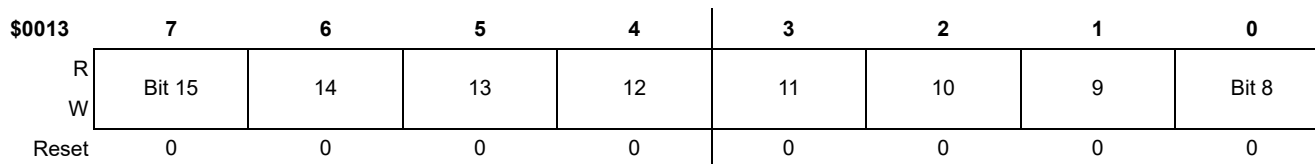

Figure 46. Timer Counter Modulo Register High (TPM1MODH)

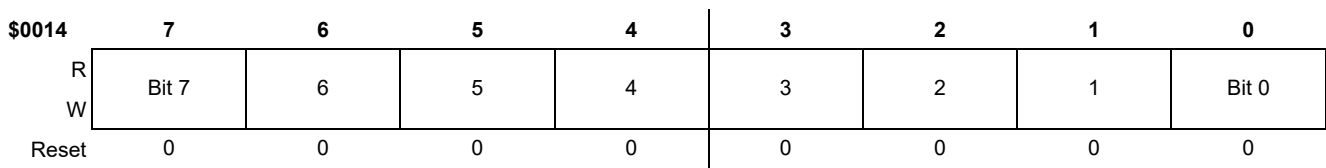

Figure 47. Timer Counter Modulo Register Low (TPM1MODL)

It is good practice to wait for an overflow interrupt so both bytes of the modulo register can be written well before a new overflow. An alternative approach is to reset the TPM1 counter before writing to the TPM1 modulo registers to avoid confusion about when the first counter overflow will occur.

9.4.4 Timer Channel 0 Status and Control Register (TPM1C0SC)

TPM1C0SC contains the channel interrupt status flag and control bits that are used to configure the interrupt enable, channel configuration, and pin function.

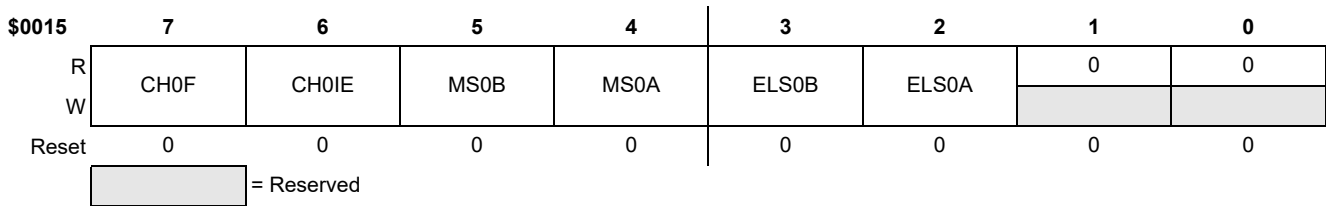

Figure 48. Timer Channel 0 Status and Control Register (TPM1C0SC)

Table 49. TPM1C0SC Register Field Descriptions

Field	Description
7 CH0F	<p>Channel 0 Flag — When channel n is configured for input capture, this flag bit is set when an active edge occurs on the channel n pin. When channel 0 is an output compare or edge-aligned PWM channel, CH0F is set when the value in the TPM1 counter registers matches the value in the TPM1 channel 0 value registers. This flag is seldom used with center-aligned PWMs because it is set every time the counter matches the channel value register, which correspond to both edges of the active duty cycle period.</p> <p>A corresponding interrupt is requested when CH0F is set and interrupts are enabled (CH0IE = 1). Clear CH0F by reading TPM1C0SC while CH0F is set and then writing a 0 to CH0F. If another interrupt request occurs before the clearing sequence is complete, the sequence is reset so CH0F would remain set after the clear sequence was completed for the earlier CH0F. This is done so a CH0F interrupt request cannot be lost by clearing a previous CH0F. Reset clears CH0F. Writing a 1 to CH0F has no effect.</p> <p>0 No input capture or output compare event occurred on channel 0 1 Input capture or output compare event occurred on channel 0</p>
6 CH0IE	<p>Channel 0 Interrupt Enable — This read/write bit enables interrupts from channel 0. Reset clears CH0IE.</p> <p>0 Channel 0 interrupt requests disabled (use software polling) 1 Channel 0 interrupt requests enabled</p>
5 MS0B	<p>Mode Select B for TPM1 Channel 0 — When CPWMS = 0, MS0B = 1 configures TPM1 channel 0 for edge-aligned PWM mode. For a summary of channel mode and setup controls, refer to Table 50.</p>
4 MS0A	<p>Mode Select A for TPM1 Channel 0 — When CPWMS = 0 and MS0B = 0, MS0A configures TPM1 channel 0 for input capture mode or output compare mode. Refer to Table 50 for a summary of channel mode and setup controls.</p>
3:2 ELS0[B:A]	<p>Edge/Level Select Bits — Depending on the operating mode for the timer channel as set by CPWMS:MS0B:MSnA and shown in Table 50, these bits select the polarity of the input edge that triggers an input capture event, select the level that will be driven in response to an output compare match, or select the polarity of the PWM output.</p> <p>Setting ELS0B:ELS0A to 0:0 configures the related timer pin as a general-purpose I/O pin unrelated to any timer channel functions. This function is typically used to temporarily disable an input capture channel or to make the timer pin available as a general-purpose I/O pin when the associated timer channel is set up as a software timer that does not require the use of a pin.</p>

Table 50. Mode, Edge, and Level Selection

CPWMS	MS0B:MS0A	ELS0B:ELS0A	Mode	Configuration
X	XX	00	Pin not used for TPM1 channel; use as an external clock for the TPM1 or revert to general-purpose I/O	
0	00	01	Input capture	Capture on rising edge only
		10		Capture on falling edge only
		11		Capture on rising or falling edge
	01	00	Output compare	Software compare only
		01		Toggle output on compare
		10		Clear output on compare
1X	10	Edge-aligned PWM	High-true pulses (clear output on compare)	
	X1		Low-true pulses (set output on compare)	
1	XX	10	Center-aligned PWM	High-true pulses (clear output on compare-up)
		X1		Low-true pulses (set output on compare-up)

If the associated port pin is not stable for at least two bus clock cycles before changing to input capture mode, it is possible to get an unexpected indication of an edge trigger. Typically, a program would clear status flags after changing channel configuration bits and before enabling channel interrupts or using the status flags to avoid any unexpected behavior.

9.4.5 Timer Channel Value Registers (TPM1C0VH:TPM1C0VL)

These read/write registers contain the captured TPM1 counter value of the input capture function or the output compare value for the output compare or PWM functions. The channel value registers are cleared by reset.

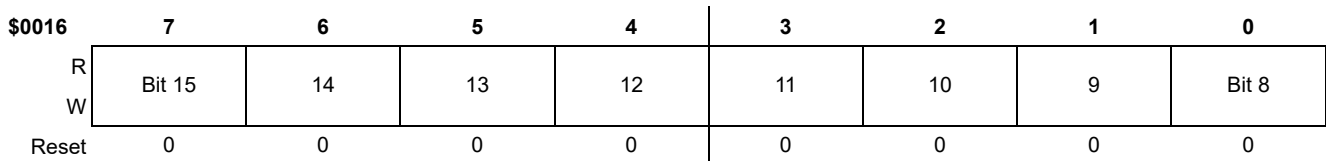

Figure 49. Timer Channel 0 Value Register High (TPM1C0VH)

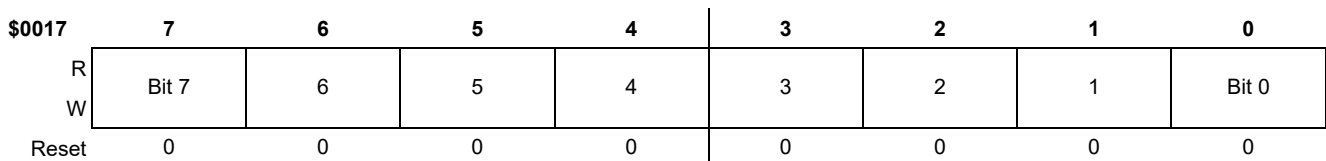

Figure 50. Timer Channel 0 Value Register Low (TPM1C0VL)

In input capture mode, reading either byte (TPM1C0VH or TPM1C0VL) latches the contents of both bytes into a buffer where they remain latched until the other byte is read. This latching mechanism also resets (becomes unlatched) when the TPM1C0SC register is written.

In output compare or PWM modes, writing to either byte (TPM1C0VH or TPM1C0VL) latches the value into a buffer. When both bytes have been written, they are transferred as a coherent 16-bit value into the timer channel value registers. This latching mechanism may be manually reset by writing to the TPM1C0SC register.

This latching mechanism allows coherent 16-bit writes in either order, which is friendly to various compiler implementations.

9.4.6 Timer Channel 1 Status and Control Register (TPM1C1SC)

TPM1C1SC contains the channel interrupt status flag and control bits that are used to configure the interrupt enable, channel configuration, and pin function.

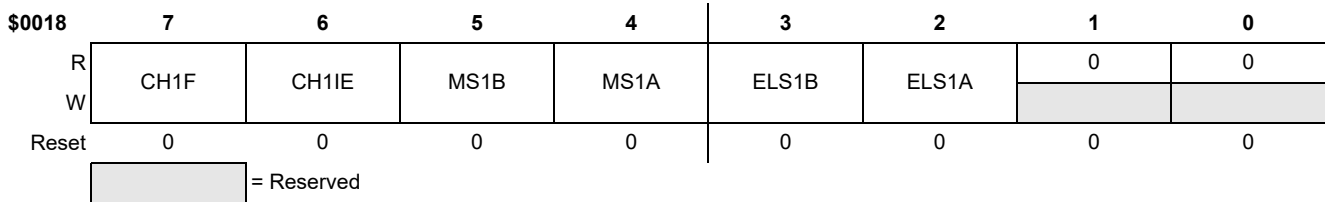

Figure 51. Timer Channel 1 Status and Control Register (TPM1C1SC)

Table 51. TPM1C1SC Register Field Descriptions

Field	Description
7 CH1F	<p>Channel 1 Flag — When channel n is configured for input capture, this flag bit is set when an active edge occurs on the channel n pin. When channel 1 is an output compare or edge-aligned PWM channel, CH1F is set when the value in the TPM1 counter registers matches the value in the TPM1 channel 1 value registers. This flag is seldom used with center-aligned PWMs because it is set every time the counter matches the channel value register, which correspond to both edges of the active duty cycle period.</p> <p>A corresponding interrupt is requested when CH1F is set and interrupts are enabled (CH1IE = 1). Clear CH1F by reading TPM1C1SC while CH1F is set and then writing a 0 to CH1F. If another interrupt request occurs before the clearing sequence is complete, the sequence is reset so CH1F would remain set after the clear sequence was completed for the earlier CH1F. This is done so a CH1F interrupt request cannot be lost by clearing a previous CH1F. Reset clears CH1F. Writing a 1 to CH1F has no effect.</p> <p>0 No input capture or output compare event occurred on channel 1 1 Input capture or output compare event occurred on channel 1</p>
6 CH1IE	<p>Channel 1 Interrupt Enable — This read/write bit enables interrupts from channel 1. Reset clears CH1IE.</p> <p>0 Channel 1 interrupt requests disabled (use software polling) 1 Channel 1 interrupt requests enabled</p>
5 MS1B	<p>Mode Select B for TPM1 Channel 1 — When CPWMS = 0, MS1B = 1 configures TPM1 channel 1 for edge-aligned PWM mode. For a summary of channel mode and setup controls, refer to Table 50.</p>
4 MS1A	<p>Mode Select A for TPM1 Channel 1 — When CPWMS = 0 and MS1B = 0, MS1A configures TPM1 channel 1 for input capture mode or output compare mode. Refer to Table 50 for a summary of channel mode and setup controls.</p>
3:2 ELS1[B:A]	<p>Edge/Level Select Bits — Depending on the operating mode for the timer channel as set by CPWMS:MS1B:MS1A and shown in Table 50, these bits select the polarity of the input edge that triggers an input capture event, select the level that will be driven in response to an output compare match, or select the polarity of the PWM output.</p> <p>Setting ELS1B:ELS1A to 0:0 configures the related timer pin as a general-purpose I/O pin unrelated to any timer channel functions. This function is typically used to temporarily disable an input capture channel or to make the timer pin available as a general-purpose I/O pin when the associated timer channel is set up as a software timer that does not require the use of a pin.</p>

Table 52. Mode, Edge, and Level Selection

CPWMS	MS1B:MS1A	ELS1B:ELS1A	Mode	Configuration
X	XX	00		Pin not used for TPM1 channel; use as an external clock for the TPM1 or revert to general-purpose I/O
0	00	01	Input capture	Capture on rising edge only
		10		Capture on falling edge only
		11		Capture on rising or falling edge
	01	00	Output compare	Software compare only
		01		Toggle output on compare
		10		Clear output on compare
		11		Set output on compare
1X	10	Edge-aligned PWM	High-true pulses (clear output on compare)	
	X1		Low-true pulses (set output on compare)	

Table 52. Mode, Edge, and Level Selection (continued)

CPWMS	MS1B:MS1A	ELS1B:ELS1A	Mode	Configuration
1	XX	10 X1	Center-aligned PWM	High-true pulses (clear output on compare-up) Low-true pulses (set output on compare-up)

If the associated port pin is not stable for at least two bus clock cycles before changing to input capture mode, it is possible to get an unexpected indication of an edge trigger. Typically, a program would clear status flags after changing channel configuration bits and before enabling channel interrupts or using the status flags to avoid any unexpected behavior.

9.4.7 Timer Channel Value Registers (TPM1C1VH:TPM1C1VL)

These read/write registers contain the captured TPM1 counter value of the input capture function or the output compare value for the output compare or PWM functions. The channel value registers are cleared by reset.

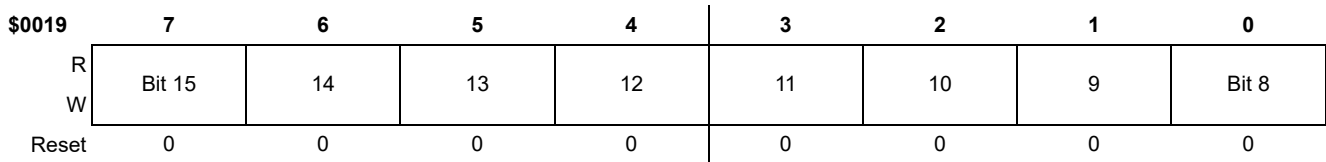

Figure 52. Timer Channel 1 Value Register High (TPM1C1VH)

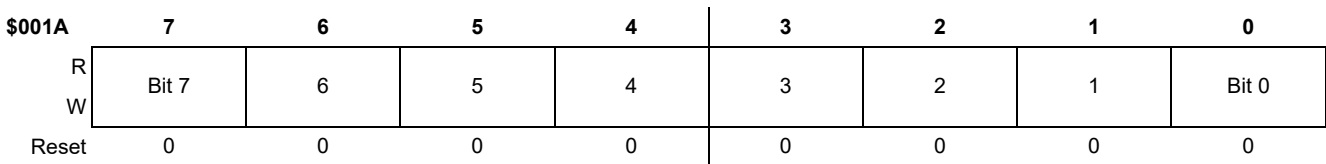

Figure 53. Timer Channel 1 Value Register Low (TPM1C1VL)

In input capture mode, reading either byte (TPM1C1VH or TPM1C1VL) latches the contents of both bytes into a buffer where they remain latched until the other byte is read. This latching mechanism also resets (becomes unlatched) when the TPM1C1SC register is written.

In output compare or PWM modes, writing to either byte (TPM1C1VH or TPM1C1VL) latches the value into a buffer. When both bytes have been written, they are transferred as a coherent 16-bit value into the timer channel value registers. This latching mechanism may be manually reset by writing to the TPM1C1SC register.

This latching mechanism allows coherent 16-bit writes in either order, which is friendly to various compiler implementations.

9.5 Functional Description

All TPM1 functions are associated with a main 16-bit counter that allows flexible selection of the clock source and prescale divisor. A 16-bit modulo register also is associated with the main 16-bit counter in the TPM1. Each TPM1 channel is optionally associated with an MCU pin and a maskable interrupt function.

The TPM1 has center-aligned PWM capabilities controlled by the CPWMS control bit in TPM1SC. When CPWMS is set to 1, timer counter TPM1CNT changes to an up-/down-counter and all channels in the associated TPM1 act as center-aligned PWM channels. When CPWMS = 0, each channel can independently be configured to operate in input capture, output compare, or buffered edge-aligned PWM mode.

The following sections describe the main 16-bit counter and each of the timer operating modes (input capture, output compare, edge-aligned PWM, and center-aligned PWM). Because details of pin operation and interrupt activity depend on the operating mode, these topics are covered in the associated mode sections.

9.5.1 Counter

All timer functions are based on the main 16-bit counter (TPM1CNTH:TPM1CNTL). This section discusses selection of the clock source, up-counting vs. up-/down-counting, end-of-count overflow, and manual counter reset.

After any MCU reset, CLKSB:CLKSA = 0:0 so no clock source is selected and the TPM1 is inactive. Normally, CLKSB:CLKSA would be set to 0:1 so the bus clock drives the timer counter. The clock source for the TPM1 can be selected to be off, the bus

clock (BUSCLK), the fixed system clock (XCLK), or an external input. The maximum frequency allowed for the external clock option is one-fourth the bus rate. Refer to [Section 9.4.1](#) and [Table 49](#) for more information about clock source selection.

When the microcontroller is in ACTIVE BACKGROUND mode, the TPM1 temporarily suspends all counting until the microcontroller returns to normal user operating mode. During STOP mode, all TPM1 clocks are stopped; therefore, the TPM1 is effectively disabled until clocks resume. During WAIT mode, the TPM1 continues to operate normally.

The main 16-bit counter has two counting modes. When center-aligned PWM is selected (CPWMS = 1), the counter operates in up-/down-counting mode. Otherwise, the counter operates as a simple up-counter. As an up-counter, the main 16-bit counter counts from 0x0000 through its terminal count and then continues with 0x0000. The terminal count is 0xFFFF or a modulus value in TPM1MODH:TPM1MODL.

When center-aligned PWM operation is specified, the counter counts upward from 0x0000 through its terminal count and then counts downward to 0x0000 where it returns to up-counting. Both 0x0000 and the terminal count value (value in TPM1MODH:TPM1MODL) are normal length counts (one timer clock period long).

An interrupt flag and enable are associated with the main 16-bit counter. The timer overflow flag (TOF) is a software-accessible indication that the timer counter has overflowed. The enable signal selects between software polling (TOIE = 0) where no hardware interrupt is generated, or interrupt-driven operation (TOIE = 1) where a static hardware interrupt is automatically generated whenever the TOF flag is 1.

The conditions that cause TOF to become set depend on the counting mode (up or up/down). In up-counting mode, the main 16-bit counter counts from 0x0000 through 0xFFFF and overflows to 0x0000 on the next counting clock. TOF becomes set at the transition from 0xFFFF to 0x0000. When a modulus limit is set, TOF becomes set at the transition from the value set in the modulus register to 0x0000. When the main 16-bit counter is operating in up-/down-counting mode, the TOF flag gets set as the counter changes direction at the transition from the value set in the modulus register and the next lower count value. This corresponds to the end of a PWM period. (The 0x0000 count value corresponds to the center of a period.)

Because the HCS08 MCU is an 8-bit architecture, a coherency mechanism is built into the timer counter for read operations. Whenever either byte of the counter is read (TPM1CNTH or TPM1CNTL), both bytes are captured into a buffer so when the other byte is read, the value will represent the other byte of the count at the time the first byte was read. The counter continues to count normally, but no new value can be read from either byte until both bytes of the old count have been read.

The main timer counter can be reset manually at any time by writing any value to either byte of the timer count TPM1CNTH or TPM1CNTL. Resetting the counter in this manner also resets the coherency mechanism in case only one byte of the counter was read before resetting the count.

9.5.2 Channel Mode Selection

Provided CPWMS = 0 (center-aligned PWM operation is not specified), the MSnB and MSnA control bits in the channel n status and control registers determine the basic mode of operation for the corresponding channel. Choices include input capture, output compare, and buffered edge-aligned PWM.

Input Capture Mode

With the input capture function, the TPM1 can capture the time at which an external event occurs. When an active edge occurs on the pin of an input capture channel, the TPM1 latches the contents of the TPM1 counter into the channel value registers (TPM1CnVH:TPM1CnVL). Rising edges, falling edges, or any edge may be chosen as the active edge that triggers an input capture.

When either byte of the 16-bit capture register is read, both bytes are latched into a buffer to support coherent 16-bit accesses regardless of order. The coherency sequence can be manually reset by writing to the channel status/control register (TPM1CnSC).

An input capture event sets a flag bit (CHnF) that can optionally generate a CPU interrupt request.

Output Compare Mode

With the output compare function, the TPM1 can generate timed pulses with programmable position, polarity, duration, and frequency. When the counter reaches the value in the channel value registers of an output compare channel, the TPM1 can set, clear, or toggle the channel pin.

In output compare mode, values are transferred to the corresponding timer channel value registers only after both 8-bit bytes of a 16-bit register have been written. This coherency sequence can be manually reset by writing to the channel status/control register (TPM1CnSC).

An output compare event sets a flag bit (CHnF) that can optionally generate a CPU interrupt request.

Edge-Aligned PWM Mode

This type of PWM output uses the normal up-counting mode of the timer counter (CPWMS = 0) and can be used when other channels in the same TPM1 are configured for input capture or output compare functions. The period of this PWM signal is determined by the setting in the modulus register (TPM1MODH:TPM1MODL). The duty cycle is determined by the setting in the timer channel value register (TPM1CnVH:TPM1CnVL). The polarity of this PWM signal is determined by the setting in the ELSnA control bit. Duty cycle cases of 0 percent and 100 percent are possible.

As Figure 54 shows, the output compare value in the TPM1 channel registers determines the pulse width (duty cycle) of the PWM signal. The time between the modulus overflow and the output compare is the pulse width. If ELSnA = 0, the counter overflow forces the PWM signal high and the output compare forces the PWM signal low. If ELSnA = 1, the counter overflow forces the PWM signal low and the output compare forces the PWM signal high.

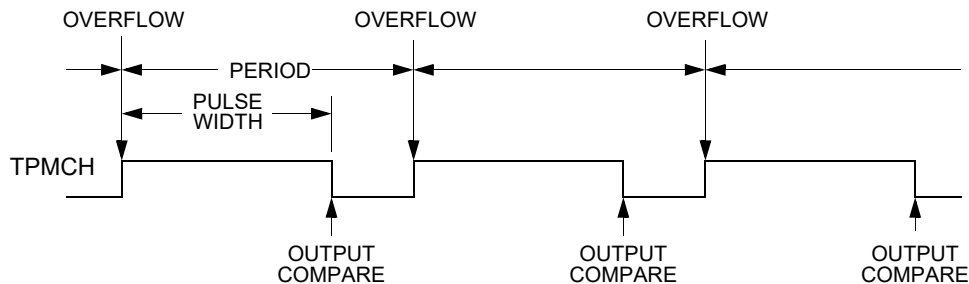

Figure 54. PWM Period and Pulse Width (ELSnA = 0)

When the channel value register is set to 0x0000, the duty cycle is 0 percent. By setting the timer channel value register (TPM1CnVH:TPM1CnVL) to a value greater than the modulus setting, 100% duty cycle can be achieved. This implies that the modulus setting must be less than 0xFFFF to get 100% duty cycle.

Because the HCS08 is a family of 8-bit MCUs, the settings in the timer channel registers are buffered to ensure coherent 16-bit updates and to avoid unexpected PWM pulse widths. Writes to either register, TPM1CnVH or TPM1CnVL, write to buffer registers. In edge-PWM mode, values are transferred to the corresponding timer channel registers only after both 8-bit bytes of a 16-bit register have been written and the value in the 1TPMCNTH:TPM1CNTL counter is 0x0000. (The new duty cycle does not take effect until the next full period.)

9.5.3 Center-Aligned PWM Mode

This type of PWM output uses the up-/down-counting mode of the timer counter (CPWMS = 1). The output compare value in TPM1CnVH:TPM1CnVL determines the pulse width (duty cycle) of the PWM signal and the period is determined by the value in TPM1MODH:TPM1MODL. TPM1MODH:TPM1MODL should be kept in the range of 0x0001 to 0x7FFF because values outside this range can produce ambiguous results. ELS0A will determine the polarity of the CPWM output.

$$\begin{aligned} \text{pulse width} &= 2 \times (\text{TPM1CnVH:TPM1CnVL}) \\ \text{period} &= 2 \times (\text{TPM1MODH:TPM1MODL}); \\ \text{for TPM1MODH:TPM1MODL} &= 0x0001\text{--}0x7FFF \end{aligned}$$

If the channel value register TPM1CnVH:TPM1CnVL is zero or negative (bit 15 set), the duty cycle will be 0%. If TPM1CnVH:TPM1CnVL is a positive value (bit 15 clear) and is greater than the (nonzero) modulus setting, the duty cycle will be 100% because the duty cycle compare will never occur. This implies the usable range of periods set by the modulus register is 0x0001 through 0x7FFE (0x7FFF if generation of 100% duty cycle is not necessary). This is not a significant limitation because the resulting period is much longer than required for normal applications.

TPM1MODH:TPM1MODL = 0x0000 is a special case that should not be used with center-aligned PWM mode. When CPWMS = 0, this case corresponds to the counter running free from 0x0000 through 0xFFFF, but when CPWMS = 1 the counter needs a valid match to the modulus register somewhere other than at 0x0000 in order to change directions from up-counting to down-counting.

Figure 55 shows the output compare value in the TPM1 channel registers (multiplied by 2), which determines the pulse width (duty cycle) of the CPWM signal. If ELSnA = 0, the compare match while counting up forces the CPWM output signal low and a compare match while counting down forces the output high. The counter counts up until it reaches the modulo setting in TPM1MODH:TPM1MODL, then counts down until it reaches zero. This sets the period equal to two times TPM1MODH:TPM1MODL.

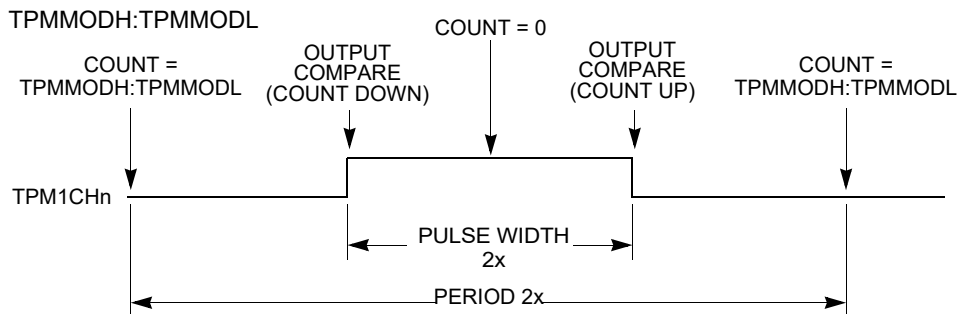

Figure 55. CPWM Period and Pulse Width (ELSnA = 0)

Center-aligned PWM outputs typically produce less noise than edge-aligned PWMs because fewer I/O pin transitions are lined up at the same system clock edge. This type of PWM is also required for some types of motor drives.

Because the HCS08 is a family of 8-bit MCUs, the settings in the timer channel registers are buffered to ensure coherent 16-bit updates and to avoid unexpected PWM pulse widths. Writes to any of the registers, TPM1MODH, TPM1MODL, TPM1CnVH, and TPM1CnVL, actually write to buffer registers. Values are transferred to the corresponding timer channel registers only after both 8-bit bytes of a 16-bit register have been written and the timer counter overflows (reverses direction from up-counting to down-counting at the end of the terminal count in the modulus register). This TPM1CNT overflow requirement only applies to PWM channels, not output compares.

Optionally, when TPM1CNTH:TPM1CNTL = TPM1MODH:TPM1MODL, the TPM1 can generate a TOF interrupt at the end of this count. The user can choose to reload any number of the PWM buffers, and they will all update simultaneously at the start of a new period.

Writing to TPM1SC cancels any values written to TPM1MODH and/or TPM1MODL and resets the coherency mechanism for the modulo registers. Writing to TPM1C0SC cancels any values written to the channel value registers and resets the coherency mechanism for TPM1C0VH:TPM1C0VL.

9.6 TPM1 Interrupts

The TPM1 generates an optional interrupt for the main counter overflow and an interrupt for each channel. The meaning of channel interrupts depends on the mode of operation for each channel. If the channel is configured for input capture, the interrupt flag is set each time the selected input capture edge is recognized. If the channel is configured for output compare or PWM modes, the interrupt flag is set each time the main timer counter matches the value in the 16-bit channel value register. See [Section 5](#) for absolute interrupt vector addresses, priority, and local interrupt mask control bits.

For each interrupt source in the TPM1, a flag bit is set on recognition of the interrupt condition such as timer overflow, channel input capture, or output compare events. This flag may be read (polled) by software to verify that the action has occurred, or an associated enable bit (TOIE or CHnIE) can be set to enable hardware interrupt generation. While the interrupt enable bit is set, a static interrupt will be generated whenever the associated interrupt flag equals 1. It is the responsibility of user software to perform a sequence of steps to clear the interrupt flag before returning from the interrupt service routine.

9.6.1 Clearing Timer Interrupt Flags

TPM1 interrupt flags are cleared by a two-step process that includes a read of the flag bit while it is set (1) followed by a write of 0 to the bit. If a new event is detected between these two steps, the sequence is reset and the interrupt flag remains set after the second step to avoid the possibility of missing the new event.

9.6.2 Timer Overflow Interrupt Description

The conditions that cause TOF to become set depend on the counting mode (up or up/down). In up-counting mode, the 16-bit timer counter counts from 0x0000 through 0xFFFF and overflows to 0x0000 on the next counting clock. TOF becomes set at the transition from 0xFFFF to 0x0000. When a modulus limit is set, TOF becomes set at the transition from the value set in the modulus register to 0x0000. When the counter is operating in up-/down-counting mode, the TOF flag gets set as the counter changes direction at the transition from the value set in the modulus register and the next lower count value. This corresponds to the end of a PWM period. (The 0x0000 count value corresponds to the center of a period.)

9.6.3 Channel Event Interrupt Description

The meaning of channel interrupts depends on the current mode of the channel (input capture, output compare, edge-aligned PWM, or center-aligned PWM).

When a channel is configured as an input capture channel, the ELSnB:ELSnA control bits select rising edges, falling edges, any edge, or no edge (off) as the edge that triggers an input capture event. When the selected edge is detected, the interrupt flag is set. The flag is cleared by the two-step sequence described in [Section 9.6.1](#).

When a channel is configured as an output compare channel, the interrupt flag is set each time the main timer counter matches the 16-bit value in the channel value register. The flag is cleared by the two-step sequence described in [Section 9.6.1](#).

9.6.4 PWM End-of-Duty-Cycle Events

For channels that are configured for PWM operation, there are two possibilities:

- When the channel is configured for edge-aligned PWM, the channel flag is set when the timer counter matches the channel value register that marks the end of the active duty cycle period.
- When the channel is configured for center-aligned PWM, the timer count matches the channel value register twice during each PWM cycle. In this CPWM case, the channel flag is set at the start and at the end of the active duty cycle, which are the times when the timer counter matches the channel value register.

The flag is cleared by the two-step sequence described in [Section 9.6.1](#).

10 Other MCU Resources

It is not intended that physical parameter measurements be made during the time that LFR may be actively receiving/decoding LF signals; or during the time that the RFM may be actively powered up and/or transmitting RF data. The resulting interactions will degrade the accuracy of the measurements.

The FXTH870x6 measures six physical parameters for use in the tire pressure monitoring application: pressure, temperature, battery voltage, two external voltages and an optional X- and/or Z-axis acceleration. Each parameter is accessed in a different manner and all use firmware subroutine calls as described in [Section 14](#). These subroutines initialize some control bits within the sensor measurement interface, SMI, and then place the MCU into the STOP4 mode until the measurement is completed with an interrupt back to the MCU.

The accuracy, power consumption and timing specified for any measurement given in the electrical specifications in [Section 17](#) are only guaranteed if the user obtains a reading using the specified firmware subroutine call in [Section 14](#).

The FXTH870x6 uses a 6-channel, 10-bit analog-to-digital converter (ADC10) module. The ADC10 module is an analog-to-digital converter using a successive approximation register (SAR) architecture with sample and hold. Capture of pressure and acceleration sensor readings is controlled by the sensor measurement interface (SMI) and capture of temperature and voltage readings are controlled by the MCU.

When making measurements of the various analog voltages the individual blocks will first be powered up long enough to stabilize their outputs before a conversion is started. The ADC channels are connected in hardware. Conversions are started and ended synchronously with the sampling of the voltages.

The accuracy, power consumption and timing specifications given in the electrical specifications in [Section 17](#) are based on using the assigned firmware subroutines in [Section 14](#) to make these measurements and convert them into an 8-bit, 9-bit or 10-bit transfer function. These measurement accuracy specifications cannot be guaranteed if the user creates custom software routines to convert these measurements.

Table 53. ADC10 Channel Assignments

ADC10 Channel	Input Select	Firmware Call(s)	Characteristic
AD0	Pressure Sensor	TPMS_READ_COMP_PRESSURE	P _{CODE}
	Optional X-axis Acceleration Sensor	TPMS_READ_COMP_ACCEL_X	A _X CODE
	Optional Z-axis Acceleration Sensor	TPMS_READ_COMP_ACCEL_Z	A _Z CODE
AD1	Temperature Sensor	TPMS_READ_COMP_TEMP_8	T _{CODE}
AD2	Bandgap Reference	TPMS_READ_COMP_VOLTAGE	V _{CODE}
AD3	GPIO PTA0	TPMS_READ_V0	G0 _{CODE}
AD4	GPIO PTA1	TPMS_READ_V1	G1 _{CODE}
AD5	V _{REG} Monitor	TPMS_WIRE_CHECK	

10.1 Pressure Measurement

The pressure measurement consists of an interface to a pressure sensing element. Control bits on the MCU operate the SMI to power up the P-Cell and capture a voltage which is converted by the ADC10. The resulting pressure transfer equation for the 100-450 kPa range:

$$P = \Delta P_{450} \times P_{\text{CODE}} + (100 - \Delta P_{450}) \quad \text{Eqn. 1}$$

The transfer equation of the 100-900 kPa range is:

$$P = \Delta P_{900} \times P_{\text{CODE}} + (100 - \Delta P_{900}) \quad \text{Eqn. 2}$$

Due to calibration routines and parameters stored in the FXTH870x6, the pressure range is selected at production and cannot be changed in the field.

NOTE

Lack of change of the pressure measurement over time may indicate the package pressure port to be blocked or the internal section of the sensor to be contaminated. User application should maintain either locally or at the system data receiver a record of pressure measurements along with temperature and/or accelerometer measurements, and possibly identify the pressure port as blocked or contaminated if no changes are recorded over time.

10.2 Temperature Measurements

The temperature is measured from a ΔV_B sensor built into channel 1 of the ADC10 in the same manner as is done in the FXTH870x6 devices with the resulting transfer equation:

$$T = \Delta T \times T_{\text{CODE}} - 55 \quad \text{Eqn. 3}$$

10.3 Voltage Measurements

Voltage measurements can be made on the internal bandgap to estimate the supply voltage on V_{DD} .

10.3.1 Internal Bandgap

An internal bandgap voltage reference is provided to take measurements of the supply voltage. The resulting transfer equation:

$$V_{\text{INT}} = \Delta V_{\text{INT}} \times V_{\text{CODE}} + 1.22 \quad \text{Eqn. 4}$$

10.3.2 External Voltages

Measurements of an external voltage on either the PTA0 or PTA1 pins can be made and referenced to the internal bandgap voltage. The resulting transfer equation:

$$V_{\text{PTAx}} = \Delta V_{\text{EXT}} \times G_x \times \text{CODE} \quad \text{Eqn. 5}$$

where $x = 0, 1$ refers to PTA0 or PTA1.

10.4 Optional Acceleration Measurements

The acceleration measurement consists of an interface to an optional acceleration sensing element. Control bits on the MCU operate the SMI to power up the g-Cell and capture a voltage which is converted by the ADC10. The data from the ADC10 is then pre-processed by a dynamic range firmware routine that will return the two values necessary to calculate the acceleration, A_y , ($y = X$ -axis or Z -axis, depending on selection) in conjunction with values taken from the table in [Section 17.10.1](#).

The first value from the firmware routine is the offset step identifier, STEP, with integer values 0 to 15 (i.e. the 16 offset steps). The other value is the ADC10 data, $A_{y\text{CODE}}$, with integer values 0 to 511. $A_{y\text{CODE}}$ values 1 through 510 are usable; values 0 and 511 indicate fault conditions. The X-axis acceleration is scaled for ~20g range within each of the 16 offset steps, ~10g per step. The Z-axis acceleration is scaled for ~80g range within each of the 16 offset steps, ~80g or ~60g. The steps are at ~40g or ~30g increments, allowing for adequate overlaps. [Section 17.10.1](#) provides a table of acceleration values resulting from characterizations.

Acceleration sensitivity, $\Delta A_{y\text{-STEP}}$, varies between each offset step, and should be calculated by dividing the range of g's for each offset step by the usable $A_{y\text{CODE}}$ range (i.e. 510):

$$\Delta A_{y\text{-STEP}} = (A_{y\text{-STEP}} @ A_{y\text{CODE}}^{510} - A_{y\text{-STEP}} @ A_{y\text{CODE}}^1) / 510 \quad \text{Eqn. 6}$$

Once the sensitivity $\Delta A_{y\text{-STEP}}$ has been calculated, the acceleration A_y can be calculated by the re-using the $A_{y\text{-STEP}} @ A_{y\text{CODE}}^1$ value of the offset step and the returned $A_{y\text{CODE}}$ value with the following transfer function:

$$A_y = \Delta A_{y\text{-STEP}} \times A_{y\text{CODE}} + (A_{y\text{-STEP}} @ A_{y\text{CODE}}^1 - \Delta A_{y\text{-STEP}}) \quad \text{Eqn. 7}$$

The pressure, and optional X or Z-axis accelerometer also share the same signal path in the Transducer interface and all the sensors share the same ADC. Therefore only one of the sensors can be accessed at a given moment.

NOTE

The included accelerometers are designed with a self-test feature. Consult sales/application support for information regarding the recommended use of the accelerometer self-test features.

10.5 Optional Battery Condition Check

The condition of the battery can be periodically checked to determine the battery's internal impedance, R_{BATT} , which is a function of both temperature and the remaining battery capacity. This can be performed by user supplied software routine and an external load resistor, R_{LOAD} , connected from the PTA0 pin to V_{SS} as shown in [Figure 56](#) (any of the PTA[3:0] can be used for this purpose).

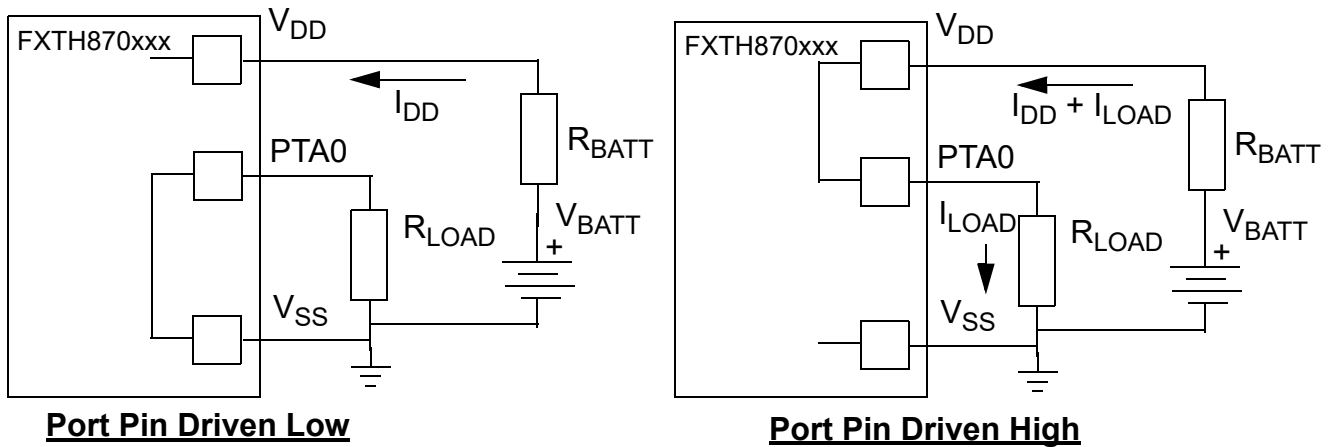

$$V_{DD0} = V_{BATT} - I_{DD0} \times R_{BATT}$$

$$V_{DD1} = V_{BATT} - (I_{DD1} + I_{LOAD}) \times R_{BATT}$$

$$V_{DD1} = V_{BATT} - \left(I_{DD1} + \frac{V_{DD1}}{R_{LOAD}} \right) \times R_{BATT}$$

Figure 56. Battery Check Circuit

The battery voltage can first be checked using the method given in [Section 10.3](#) with the selected PTA0 pin set as an output and driven low and then high to determine V_{DD} where only I_{DD} flows or when I_{DD} plus I_{LOAD} flows. The resulting battery impedance can then be calculated as:

$$R_{BATT} = \frac{V_{DD1} - V_{DD0}}{I_{DD0} - I_{DD1} + \frac{V_{DD1}}{R_{LOAD}}} \quad \text{Eqn. 8}$$

If it is assumed that I_{DD0} and I_{DD1} are not appreciably different at the small change in V_{DD} , then the resulting battery impedance can be approximated as:

$$R_{BATT} = \frac{V_{DD1} - V_{DD0}}{\frac{V_{DD1}}{R_{LOAD}}} = \frac{R_{LOAD} \times (V_{DD1} - V_{DD0})}{V_{DD1}} \quad \text{Eqn. 9}$$

where:

- V_{DD0} is the voltage determined with the external load resistor connected to V_{SS}
- V_{DD1} is the voltage determined with the external load resistor connected to V_{DD}
- R_{LOAD} is the resistance of the external load resistance in ohms
- R_{BATT} is the implied battery impedance in ohms

It is recommended that this calculation be performed with a reasonable current load on the battery of approximately 3 mA (R_{LOAD} approximately 1000 ohms).

10.6 Measurement Firmware

The firmware for making measurements is comprised of two function calls as described in [Section 14](#). Each measurement is a combination of a “read” that returns the raw ADC output data and a “comp” routine which compensates that raw reading based on information contained in the Universal Uncompensated Measurement Array (UUMA) assigned in RAM memory.

The read routines fill specific locations in the UUMA with raw data; but the compensation routines depend what is already present in the UUMA as shown in the data flow in [Figure 57](#).

The user therefore has the option to decide how often each measurement (and its component terms) are made. The resulting power consumption is then the sum of using these components are defined in the electrical specifications in [Section 17](#).

A typical flow for a compensated pressure measurement would be:

1. Call the TPMS_READ_PRESSURE routine which yields a raw pressure value and fills the UUMA with this data.
2. Call the TPMS_READ_TEMPERATURE routine which yields a raw temperature value and fills the UUMA with this data.
3. Call the TPMS_READ_VOLTAGE routine which yields a raw voltage value and fills the UUMA with this data.
4. Call the TPMS_COMP_PRESSURE routine which then takes the raw pressure, temperature and voltage values from the UUMA and compensates to provide a true pressure reading to the accuracy as specified in [Section 17](#).

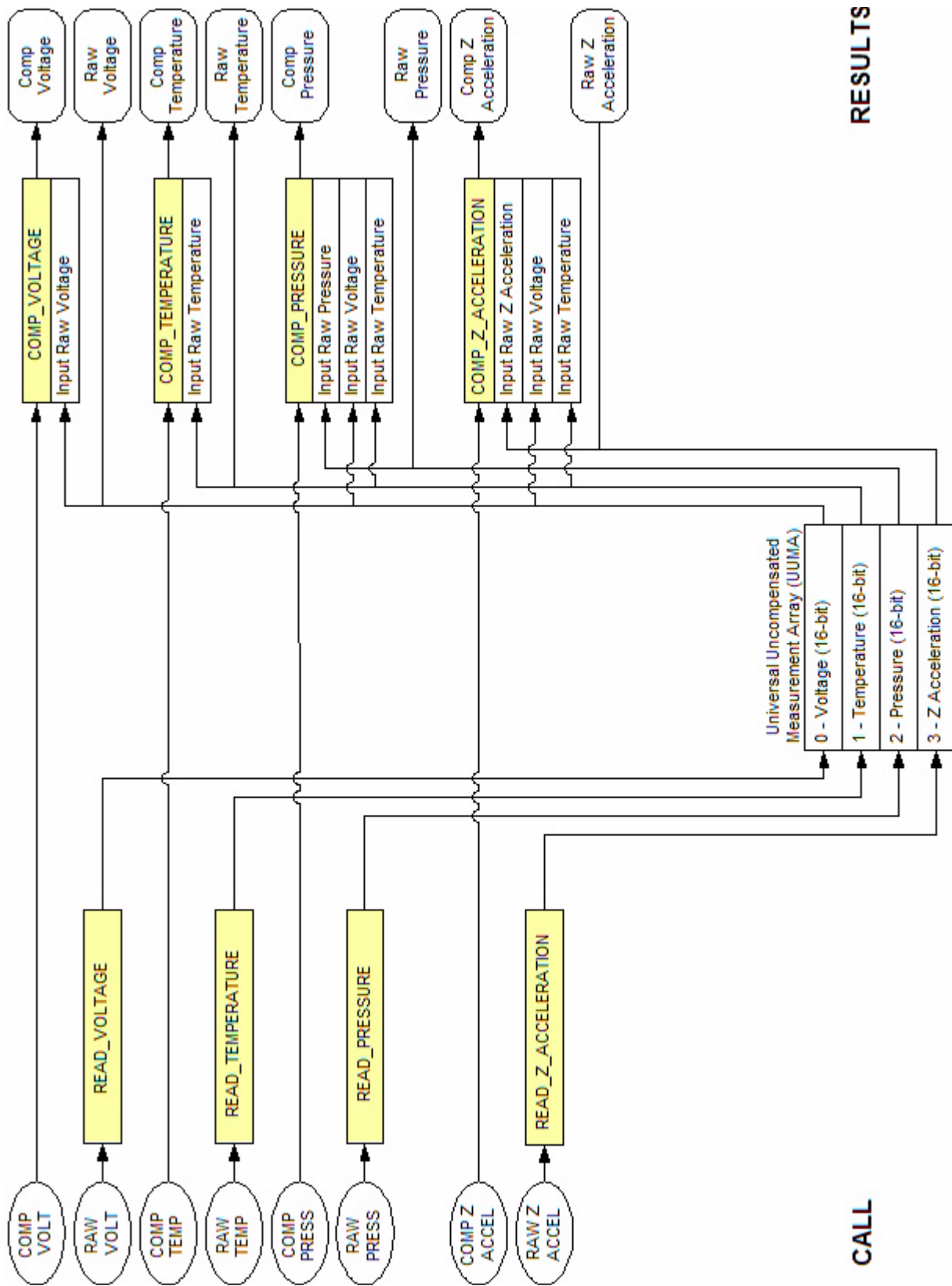

Figure 57. Data Flow For Measurements

10.7 Thermal Shutdown

When the package temperature becomes too low or too high the MCU can be placed into a STOP mode to suspend operation and prevent transmission of RF signals which may be corrupted at the temperature extremes. Return to normal operation after the temperature falls back within the recovery temperature range. The presence of either the low or high temperature shutdown will disable the PWU from causing either a periodic wakeup or a periodic reset. The MCU, temperature sensor and ADC10 are all functional over the full temperature range from T_L to T_H .

10.7.1 Low Temperature Shutdown

Low temperature shutdown is achieved using temperature readings taken by the ADC10 as described in [Section 10.2](#) and enabling the thermal restart circuit by setting the TRE bit and selecting the low temperature threshold by clearing the TRH bit. When the software programmed low temperature is reached the MCU will turn off all operating functions and enter the STOP1 mode.

10.7.2 High Temperature Shutdown

The high temperature shutdown level is determined from a measurement of the temperature sensor by the ADC10 as described in [Section 10.2](#) and enabling the thermal restart circuit by setting the TRE bit and selecting the high temperature threshold by setting the TRH bit. When the software programmed high temperature is reached the MCU will turn off all operating functions and enter the STOP1 mode.

10.7.3 Temperature Shutdown Recovery

The MCU can be restarted by the Temperature Restart (TR) module when the temperature returns within the normal temperature range, T_{RESET} . When this occurs the MCU will be reset and begin execution from the reset vector located at $\$DFFE/\$DFFF$. The TR module can be enabled using the TRE bit in the SIMOPT1 register. The TR module can be powered on and off by setting or clearing the TRE bit located at bit 3 in the SIMOPT1 register at address $\$1802$. The TRE bit is cleared by an MCU reset.

When the TRE bit is set the TR module can then be set to detect a recovery from either a high temperature or a low temperature using the TRH in the SIMOPT1 register. The TRH bit is cleared by an MCU reset.

The TR module does not activate an MCU restart and reset unless it has first moved outside the re-arming temperature range, T_{REARM} , as shown in [Figure 58](#). The status of the TR can be checked by reading the TRO bit located at bit 0 in the SIMTST register at address $\$180F$. The TRO bit is set high by an MCU reset. The state of the TRO bit is as follows:

- 1 = TR module is outside the T_{REARM} temperature range and will restart the MCU if the TRE bit is set and temperature falls back within the T_{RESET} temperature range.
- 0 = TR module is within the T_{RESET} temperature range and the MCU cannot be armed to restart when temperature falls back to the T_{RESET} range. The TRE bit cannot be set.

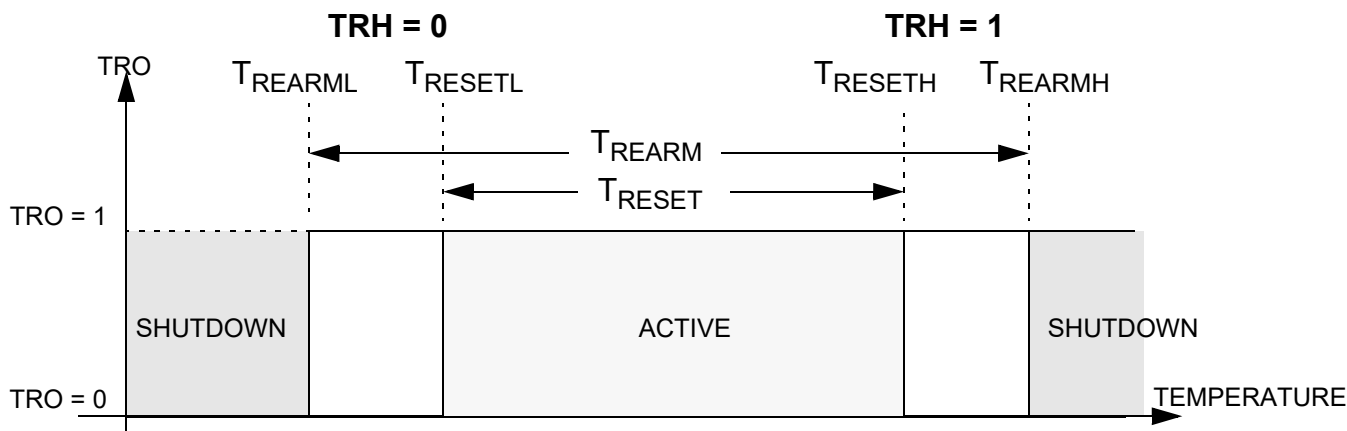

Figure 58. Temperature Restart Response

This sequence is further explained by the user software flowchart in [Figure 59](#).

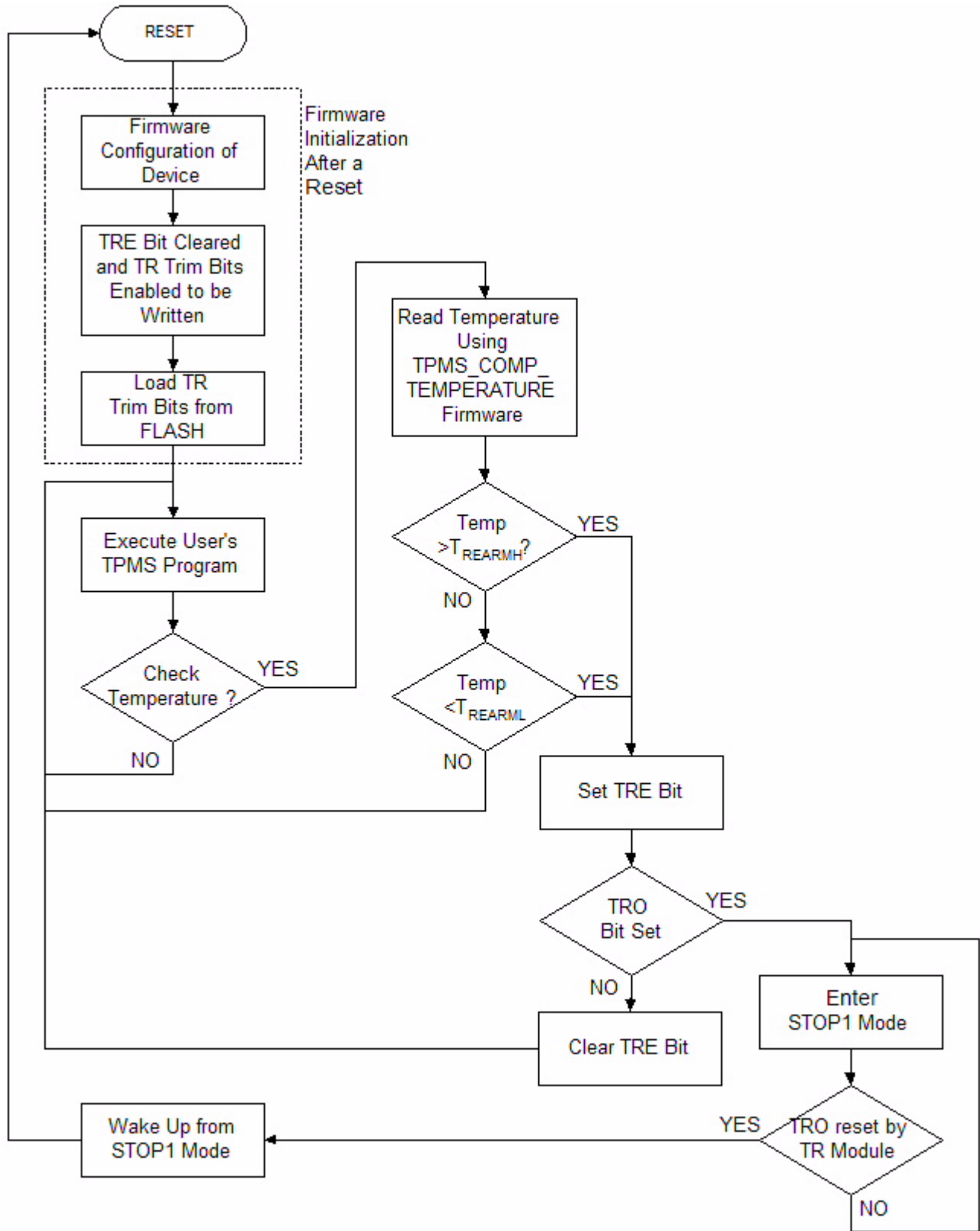

Figure 59. Flowchart for Using TR Module

11 Periodic Wakeup Timer

The periodic wakeup timer (PWU) generates a periodic interrupt to wakeup the MCU from any of the STOP modes. It also has an optional periodic reset to restart the MCU. It is driven by the LFO oscillator in the RTI module which generates a clock at a nominal one millisecond interval. The LFO and the wakeup timer are always active and cannot be powered off by any software control. The control bits are set so that there is either a periodic wakeup, a periodic reset, or both a wakeup interrupt and a periodic reset. No combination of control bits will disable both the wakeup interrupt and the periodic reset. In addition, there is no hardware control that can mask a wakeup interrupt once it is generated by the PWU.

11.1 Block Diagram

The block diagram of the wakeup timer is shown in Figure 60. This consists of a programmable prescaler with 64 steps that can be used to adjust for variations in the value of the LFO period. Finally there are two cascaded programmable 6-bit dividers to set wakeup and/or reset time intervals.

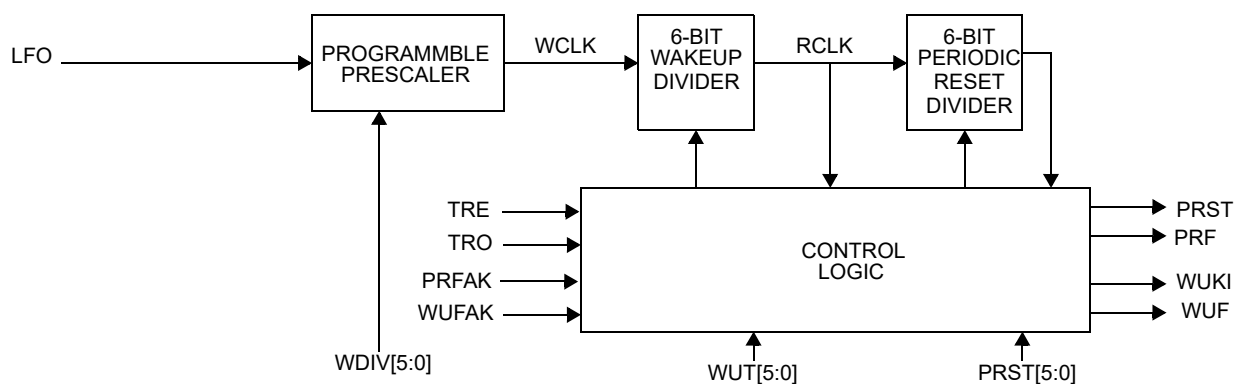

Figure 60. Wakeup Timer Block Diagram

The wakeup divider (PWUDIV) register selects a division of the incoming 1 ms clock to generate a wakeup clock, WCLK. The WCLK frequency can be calibrated against the more precise external oscillator using the TPMS_LFOCOL firmware subroutine as described in Section 14. This subroutine turns on the RFM crystal oscillator and feeds a 500 kHz clock to the TPM1 for one cycle of the LFO. The measured time is used to calculate the correct value for the WDIV[5:0] bits for a WCLK period of 1 second. The TPMS_LFOCOL subroutine cannot be used while the RFM is transmitting or the TPM1 is being used for another task.

The wakeup time register (PWUSC0) selects the number of WCLK pulses that are needed to generate a wakeup interrupt to the MCU. The periodic reset register (PWUSC1) selects the number of wakeup pulses that are needed to generate a periodic reset of the MCU. Both the wakeup time counter and the periodic reset timer are incrementing counters that generate their interrupt or reset when the desired count is reached and are then reset to zero. Reading the status of either of these counters will return a zero content if done immediately after the interrupt or reset is generated.

If both the reset and the interrupt occur on the same clock cycle the reset will have precedence and the interrupt will not be generated.

In order to prevent wakeup or reset from an extreme temperature event both the wakeup interrupt or periodic reset are disabled if the thermal restart is activated and the TRO bit indicates that the device is still outside of the T_{RESET} range. The wakeup and periodic reset counters will still run. The state of these counters can be read using the PSEL bit in the PWUS register.

The wakeup interrupt (WUKI) cannot be masked by clearing the I-bit.

11.2 Wakeup Divider Register - PWUDIV

The PWUDIV register contains six bits to select the division of the incoming 1 ms clock period as described in [Figure 61](#).

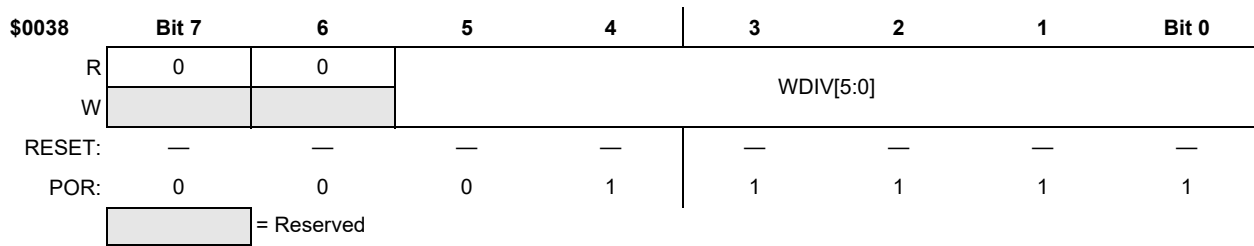

Figure 61. PWU Divider Register (PWUDIV)

Table 54. PWUDIV Register Field Descriptions

Field	Description
7:6 Unused	Unused
5:0 WDIV[5:0]	<p>Wakeup Divider Value — The WDIV[5:0] bits select an incoming prescaler for the incoming 1 ms clock period from 504 to 1512. This results in a clocking of the 6-bit wakeup divider at rates from a nominal 0.504 to 1.512 sec per wakeup clock, WCLK. The user can use this prescaler to fine tune the wakeup time based on the variation in the LFO frequency. The conversion from the decimal value of the WDIV bits to the nominal WCLK period is given as:</p> $t_{WCLK} = \frac{(504 + 16 \times WDIV)}{f_{LFO}}$ <p>A power on reset presets these bits to a value of \$1F (decimal 31) which yields a nominal 1 second output period for WCLK. Other resets have no effect on these bits.</p>

11.3 PWU Control/Status Register 0 - PWUCS0

The PWUCS0 register contains six bits to select the division of the incoming WCLK clock period and provide interrupt flag and acknowledge bits as described in [Figure 62](#). The period of the resulting interrupt also generates the clock, RCLK, for the periodic reset timing.



Figure 62. PWU Control/Status Register 0 (PWUCS0)

Table 55. PWUCS0 Register Field Descriptions

Field	Description
7 WUF	<p>Wakeup Interrupt Flag — The WUF bit indicates when a wakeup interrupt has been generated by the PWU. This bit is cleared by writing a one to the WUFAK bit. Writing a zero to this bit has no effect. Reset clears this bit.</p> <p>0 Wakeup interrupt not generated or was previously acknowledged. 1 Wakeup interrupt generated.</p>
6 WUFAK	<p>Acknowledge WUF Interrupt Flag — The WUFAK bit clears the WUF bit if written with a one. Writing a zero to the WUFAK bit has no effect on the WUF bit. Reading the WUFAK bit returns a zero. Reset has no effect on this bit.</p> <p>0 No effect. 1 Clear WUF bit.</p>

Table 55. PWUSC0 Register Field Descriptions (continued)

Field	Description
5:0 WUT[5:0]	<p>WUF Time Interval — These control bits select the number of WCLK clocks that are needed before the next wakeup interrupt is generated. The count gives a range of wakeup times from 1 to 63 WCLK clocks.</p> <p>Depending on the value of the bits for the WDIV[5:0] this time interval can nominally be from 1 to 63 seconds in 1 second steps. Whenever the WUT[5:0] bits are changed the timeout period is restarted. Writing the same data to the WUT[5:0] bits has no effect.</p> <p>Writing zeros to all of the WUT[5:0] bits forces the wakeup divider to a value of \$3F and disables the wakeup interrupt. However, writing all zeros to the WUT[5:0] bits is inhibited if all of the PRST[5:0] bits are already cleared to zero. This prevents disabling both the periodic wakeup and the periodic reset at the same time. See Table 56.</p> <p>The WUT[5:0] bits are preset to a value of \$3F (decimal 63) by any resets.</p>

Table 56. Limitations on Clearing WUT/PRST

Control Bits	State of Control Bits	Control Bits to be Cleared	Resulting Action	Resulting Wakeup Interrupt	Resulting Periodic Reset
WUT[5:0]	non-zero	PRST[5:0]	Allowed	Enabled ⁽¹⁾	Disabled
	all zero		Inhibited	Disabled ⁽²⁾	Enabled ⁽¹⁾
PRST[5:0]	non-zero	WUT[5:0]	Allowed	Disabled	Enabled ⁽¹⁾
	all zero		Inhibited	Enabled ⁽¹⁾	Disabled

- Using previous values.
- Wakeup divider preset to \$3F.

11.4 PWU Control/Status Register 1 - PWUCS1

The PWUSC1 register contains six bits to select the division of the incoming RCLK clock period and provide interrupt flag and acknowledge bits as described in [Figure 63](#).

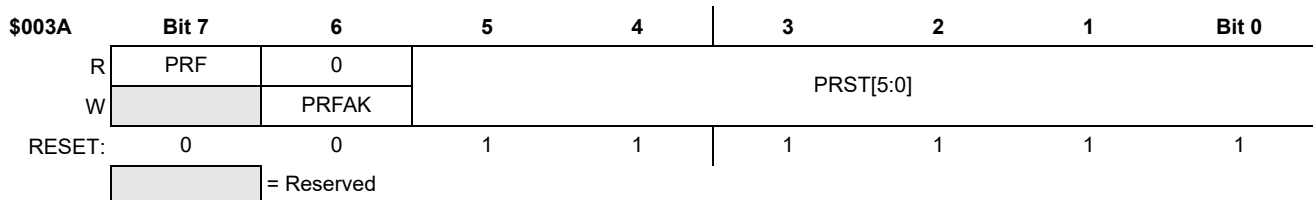

Figure 63. PWU Control/Status Register 1 (PWUCS1)

Table 57. PWUSC1 Register Field Descriptions

Field	Description
7 PRF	<p>Periodic Reset Flag — The PRF bit indicates when a periodic reset has been generated by the PWU. MCU writes to this bit have no effect. This bit is cleared by writing a one to the PRFAK bit. This bit is cleared by a power on reset, but is unaffected by other resets.</p> <p>0 Periodic reset not generated or previously acknowledged. 1 Periodic reset generated.</p>
6 PRFAK	<p>Acknowledge PRF Interrupt Flag — The PRFAK bit clears the PRF bit if written with a one. Writing a zero to the PRFAK bit has no effect on the PRF bit. Reading the PRFAK bit returns a zero. Reset has no effect on this bit.</p> <p>0 No effect. 1 Clear PRF bit.</p>
5:0 PRST[5:0]	<p>Periodic Reset Time Interval — These control bits select the number of wakeup interrupts that are needed before the next periodic reset is generated. The decimal count gives a range of periodic reset times from 1 to 63 wakeup interrupts. Depending on the value of the bits for the WDIV[5:0] and WUT[5:0] this time interval can nominally be from 1 second to 66 minutes with steps from 1 to 63 seconds. Whenever the PRST[5:0] bits are changed the timeout period is restarted. Writing the same data to the PRST[5:0] bits has no effect.</p> <p>Writing zeros to all of the PRST[5:0] bits forces the periodic reset to be disabled if at least one of the WUT[5:0] bits is set to a one. This assures that there will be at least a wakeup interrupt. However, writing all zeros to the PRST[5:0] bits is inhibited if all of the WUT[5:0] bits are already cleared to zero. This prevents disabling both the periodic wakeup and the periodic reset at the same time. See Table 56. The PRST[5:0] bits are preset to a value of 63 by any resets.</p>

11.5 PWU Wakeup Status Register - PWUS

The PWUS register shows the current status of the two PWU counters as described in Figure 63. The counter contents are captured when the register is read.

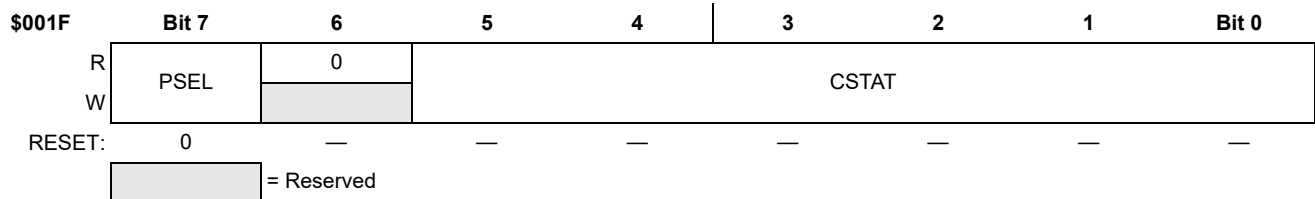

Figure 64. PWU Wakeup Status Register (PWUS)

Table 58. PWUS Register Field Descriptions

Field	Description
7 PSEL	Page Selection — The PSEL read/write bit selects whether the other bits are read from the WUT or PRST counters. This bit is cleared by a power on reset that is not created by an exit from the STOP mode, but is unaffected by other resets. 0 CSTAT = WUT counter status 1 CSTAT = PRST counter status
6 unused	Unused — An unused bit that always reads as a logical zero.
5:0 CSTAT	Counter Status — These read-only bits show the status of the counter selected by the PSEL bit. The effects of any reset on these bits depends on how the reset affects the selected counter. Reading these counters immediately after a WUF or PRF generated flag will return zero contents.

11.6 Functional Modes

PWU module will work in each of the MCU operating modes as follows:

11.6.1 RUN Mode

If the module generates a wakeup interrupt the PC (Program Counter) will be redirected to the wakeup timer interrupt vector. The WUF flag will be set to indicate wakeup timer interrupt; write 1 to WUFACK to clear this flag.

If the module generates a reset the PC will be redirected to the reset vector. The PRF flag will be set to indicate periodic reset; write 1 to PRFACK to clear this flag.

All registers will continue to hold their programmed values after interrupt or reset is taken.

11.6.2 STOP4 Mode

If the module generates a wakeup interrupt the bus and core clocks will be restarted and the PC will be redirected to the wakeup timer interrupt vector. The WUF flag will be set to indicate wakeup timer interrupt; write 1 to WUFACK to clear this flag.

If the module generates a periodic reset the bus and core clocks will be restarted and the PC will be redirected to the reset vector. The PRF flag will be set to indicate periodic reset; write 1 to PRFACK to clear this flag.

All registers will continue to hold their programmed values after interrupt or reset is taken.

11.6.3 STOP1 Mode

If the module generates a wakeup interrupt the module will cause the MCU to exit the power saving mode as a POR. MCU will have the wakeup interrupt pending and once CLI opcode is executed PC will be redirected to wakeup interrupt vector address. The WUF flag will be set to indicate wakeup timer interrupt; write 1 to WUFACK to clear this flag.

If the module generates a periodic reset the module will cause the MCU to exit the power saving mode as a POR. The PRF flag will be set to indicate periodic reset; write 1 to PRFACK to clear this flag. The SRS register will have just the POR bit set.

In this STOP mode exit all registers will continue to hold their programmed values.

11.6.4 Active BDM/Foreground Commands

The PWU is frozen in ACTIVE BACKGROUND mode or executing foreground commands, so PWU counters will also be stopped. Normal PWU operation will resume as MCU exits BDM or foreground command is finished.

12 LF Receiver

The low-frequency receiver (LFR) is a very low-power, low-frequency, receiver system for short-range communication in TPMS. The module allows an external coil to be connected to two dedicated differential input pins. In TPMS systems a single coil may be oriented for optimal coupling between the receiver in the tire or wheel and a transmitter coil on the vehicle body or chassis.

This LFR system minimizes power consumption by allowing flexibility in choosing the ratio of on to off times and by turning off power to blocks of circuitry until they are needed during signal reception and protocol recognition. In addition, this LFR system can autonomously listen for valid LF signals, check for protocol and ID information so the main MCU can remain in a very low power standby mode until valid message data has been received.

The LFR can be configured for various message protocols and telegrams to allow it to be used in a broad range of applications. The message preamble must be a series of Manchester coded bits at the nominal 3.906-kbps data rate. A synchronization pattern is used to mark the boundary between the preamble and the beginning of Manchester encoded information in the message body. The synchronization pattern is a non-Manchester specific TPMS pattern. Messages can optionally include none, an 8-bit or a 16-bit ID value. Messages may contain any number of data bytes with the end-of-message indicated by detecting an illegal Manchester bit at a data byte boundary.

It is not intended that LFR may be actively receiving/decoding LF signals while physical parameter measurements are being made; or during the time that the RFM may be actively powered up and/or transmitting RF data. The resulting interactions will degrade the accuracy of the LF detection.

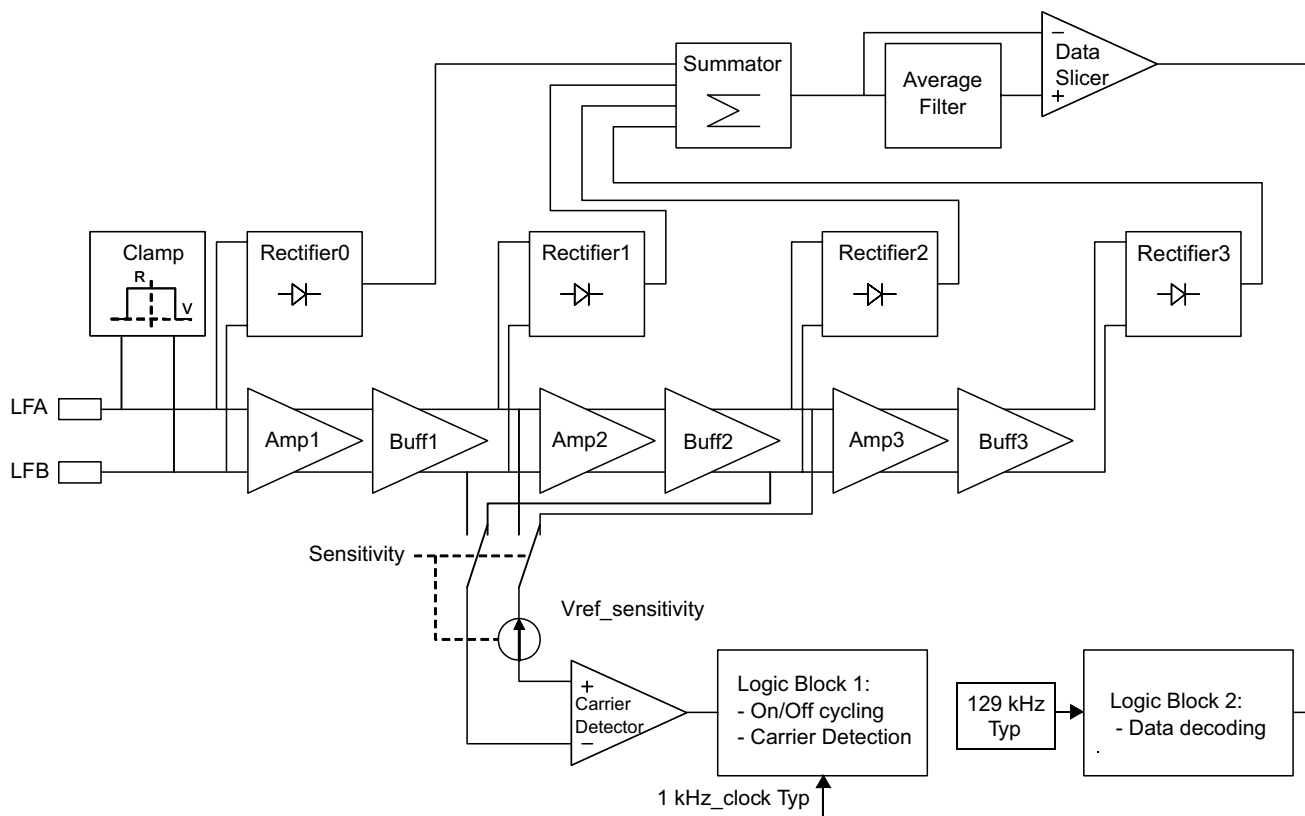

Figure 65. Block Diagram

For definitions of the acronyms and detailed descriptions of the bits and/or byte registers, please refer to [Section 12.17](#).

12.1 Features

Major features of the LFR module include:

- Differential input LF detector (two dedicated pins):
 - Selectable sensitivity (two levels: Low Sens (LS) and High Sens (HS)).
 - Thresholds trimmed at the factory with trim setting saved in nonvolatile memory.
 - LFR has a reference oscillator (LFRO) trimmed at the factory with trim setting saved in nonvolatile memory.
 - Selectable signal sampling time interval and on-time.
 - Sample interval and on times controlled by LFR state machine or directly by the MCU.
- Configurable receive mode:
 - Simple LF carrier detection/Telegram decode. (CARMOD)
- Configurable message protocol (telegram structure):
 - Various SYNC decoding (SYNC[1:0])
 - 6-bit time SYNC requirements
 - 7.5-bit time SYNC requirements
 - 9-bit time SYNC requirements
 - Optional ID (ID[1:0])
 - 8-bit or 16-bit ID
 - On or off
 - 0-n bytes of message data. End-of-data marked by loss of Manchester at a byte boundary.
- Optional continuous monitoring and decode of the LF detector.
- Selectable MCU interrupt when a received data byte is ready in an LFR buffer, when a Manchester error is detected in the frame, when an ID is received or when a valid carrier has been detected.

12.2 Modes of Operation

The LFR is a peripheral module on an MCU. After being configured by application software, the LFR can operate autonomously to detect and verify incoming LF messages. When a valid message or carrier pulse is received and verified the LFR can wake the MCU from standby modes to read received data or act upon a carrier detection.

The primary modes of operation for the LFR are:

- Disabled. Everything off and drawing minimal leakage current. LFR register contents will be retained.
- Carrier detect/listen. Minimum circuitry enabled to detect any incoming LF signal, check it for the appropriate signal level, frequency and duration.
- TPMS protocol verification.
- Data reception.

12.3 Power Management

In addition to using low power circuit design techniques, the LFR module provides system-level features to minimize system energy requirements. In an MCU that includes the LFR module, all MCU circuitry except a very low current 1-kHz oscillator (LFO) and minimum regulator circuitry can be disabled. After a reset, the MCU would initialize the LFR module and then enter a very low power standby mode (depending upon the MCU, this could be lower than 1 uA for the MCU portion). The LFR module includes everything it needs to periodically listen for LF messages, perform Manchester decoding, verify the message telegram, and assemble incoming data into 8-bit bytes. The LFR does not wake the MCU unless a valid message is being received and a data byte is ready to be read.

The LFR cycles between an off state, where everything is disabled, and an on state, where it listens for a carrier signal. The on time is controlled by LFONTM[3:0] control bits in the LFCTL2 register. The time between the start of each sample on time is controlled by LFSTM[3:0] control bits in the LFCTL2 register. Even lower duty cycles can be achieved by using the MCU to wake once per second and maintain a software counter to delay for an arbitrarily long time before enabling the LFR to perform a series of carrier detect cycles.

Within the LFR, circuits remain disabled until they are needed. When the LFR is listening for a carrier signal, only a 1-kHz clock source, a portion of the input amplifier and a periodic auto-zero are running. After a carrier signal is detected, with high enough amplitude, frequency and duration the LFRO oscillator is enabled so the LFR can begin to decode the incoming information.

The LFR module has a power up settling time of 2-LFO period before any active operations. In the ON/OFF cycle, those 2 ms are hidden in the sampling time during the off time.

12.4 Input Amplifier

The LFR module receives LF modulated signals through a dedicated differential pair of inputs which is connected to an external coil. The enable control (LFEN) allows the user to enable the LF input depending on the application requirements. The SENS[1:0] bits in the LFCTL1 register allows the user to select one of two input sensitivity thresholds which determines the signal level required before the input carrier will be detected. The sensitivity setting is used during carrier detection but does not affect reception after the carrier has been detected. When the CARMOD bit is cleared, after a carrier with sufficient amplitude, frequency and duration has been detected the output stage of the amplifier is turned on to allow data reception.

12.5 LFR Data Mode States

The modes of operation the LFR state machine will sequence as shown in [Figure 66](#).

12.6 Carrier Detect

Carrier detection includes a check for a certain number of edges on a signal that is greater than the input sensitivity threshold. During the check for carrier edges, only the 1kHz low frequency oscillator (LFO) clock source is running so power consumption remains very low.

During carrier detection the incoming signal is amplified and passed through a sensitivity threshold comparator. The SENS[1:0] bits in the LFCTL1 register selects two levels of sensitivity and determines the signal amplitude that is needed to allow edges to be seen at the output of the sensitivity threshold comparator. When a carrier is above this threshold, a block is powered on and validates the carrier. This frequency and duration check function can be disabled by clearing the VALEN bit. If VALEN is set, the block checks for the carrier duration and the carrier frequency. The time needed to validate a carrier is programmed by the LFCDTM register. The carrier frequency should be 125 kHz. If the signal above the threshold is not within the frequency range or not present during enough time, then the carrier will not be validated and the validation block will turn off.

If no carrier signal is validated within the on time of the LFR, the state machine returns to the off state and the alternating cycle of on time and off time continues. Carrier edge counts start at zero when a new on time begins.

In the data mode (CARMOD = 0), if the required number of carrier edges are detected before the end of the ON time, the LFR will remain ON to complete the reception of a message telegram.

In the carrier detect mode (CARMOD = 1) there is no need to enable other LFR circuitry to evaluate any other message components after the required number of carrier edges are detected. One or several consecutive carriers can be validated by this process before the LFCDF flag is set. The LFCC control bits are used to program the number of consecutive ON times where a complete carrier validation is needed before interrupting the MCU. In this case, the LFCDF flag is set and, provided the LFCDFIE interrupt enable is also set, an interrupt is issued to wake the MCU. In carrier detect mode, the LFCDFIE control bit should always be set because the intended purpose of the carrier detect mode is to wake the MCU when a carrier is detected. When LFCDF is set, the LFR waits until it is cleared before it continues the alternating cycle of on time and off time, starting with an off time.

In data mode, when a carrier is detected the averaging filter is powered on and the LFR continues to the next state to look for the rest of a message telegram; and the LFR module will search for valid SYNC word (with length programmed through the SYNC bits in the LFCTL3 register depending on preamble type). If the external LF field is not a TPMS frame, a timeout will turn off the LFR module. This timeout can be program through TIMOUT bit the LFCTL4 register.

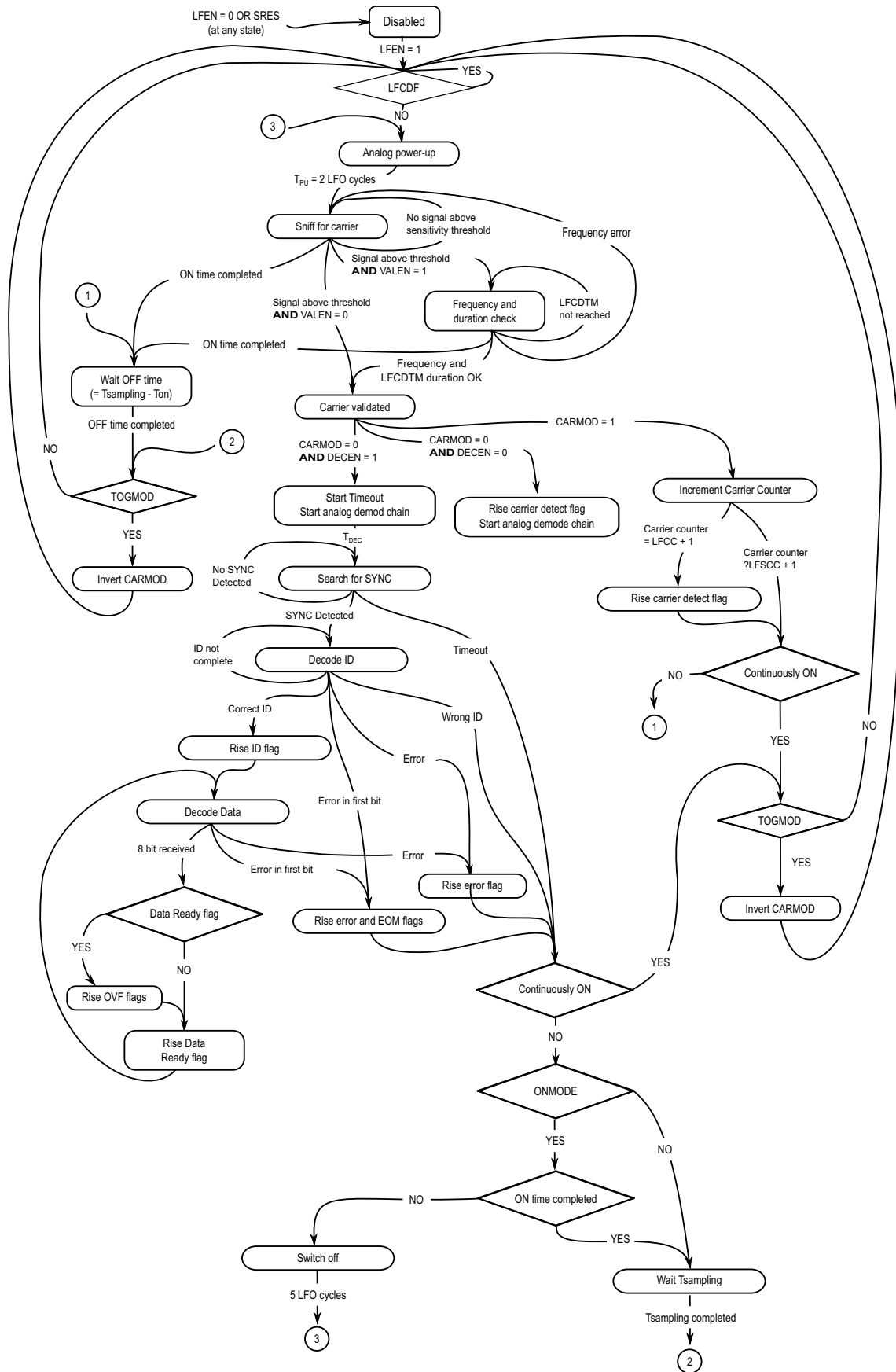

Figure 66. FXTH870x6 LFR State Machine Diagram

12.7 Auto-Zero Sequence

An auto-zero sequence is performed periodically on the input amplifier to cancel offset errors. During reception of the SYNC pattern and body of the message, auto-zero operations are synchronized to data edges of the incoming signal to avoid interfering with normal reception. During the auto-zero sequence, the input amplifier is temporarily disconnected from the external coil and connected to ground. The auto-zero sequence takes roughly 64 μ sec. It is performed at each LFO period in carrier mode and on one over four decoded data edges in data mode.

When the DECEN bit is cleared, the auto-zero sequence is performed at each LFO period. During the 64 μ sec of the auto-zero sequence, the receiver is holding the state "0" or "1" previously decoded. Since the LFR receiver is not active during this time, the possible data-rate that the analog can detect is at least limited by this duration.

12.8 Data Recovery

Rectified signals from the amplifier output are connected to the input of an averaging filter and data slicer. The slicer thus compares the rectified signal with its own average value to decode the data. When a carrier is present, the slicer output voltage rises and when the carrier stops the slicer output voltage falls. The output of this comparator provides a binary digital signal that indicates whether the carrier is present or not. This digital signal is connected to the data clock recovery circuit, the SYNC detect circuit, and the Manchester decoder circuit.

The Manchester decoder uses the digital output of the data slicer to detect the logic level of each incoming data bit and to synchronize the decoder state machine. The LFPOL polarity bit in the LFCTRLA register selects the expected encoding of the Manchester data bit.

If a strong signal (above roughly 100 mV p-p differential) is entered into the LFR, the input impedance will switch instantaneously to a lower programmed value (the LOWQ[1:0] bits in the LFCTRLC) and be maintained during the current data packet if the DEQEN bit is set. At the next ON time, the default high input impedance will be set again. The strong signal detection and the automatic impedance change can be disabled by clearing the DEQEN bit.

12.9 Data Clock Recovery and Synchronization

Data clock recovery and synchronization takes place during the SYNC portion of an incoming message. The preamble must be modulated Manchester data. The type of required SYNC pattern determines the allowed preamble type depending on the SYNC[1:0] control bits.

The design data rate is 3.906 kbps which gives a bit time equivalent to about 32 cycles of the LF carrier frequency. In a Manchester encoded bit time, the carrier should be present for either the first half or the second half of the bit time depending on whether the bit is a logic zero or a logic one.

The LFRO clock source is 32 times the target data rate. The LFRO is used for decoding data and also sequencing auto-zero operations.

12.10 Manchester Decode

When the LFPOL bit is clear, a logic one bit is defined as no LF carrier present for the first half of the bit time; and a logic zero bit is defined as LF carrier present for the first half of the bit time as shown in [Figure 67](#). Another way to say this from the point of view of the data slicer output is that a logic zero bit has a falling edge at the middle of the bit time and a logic one bit has a rising edge at the middle of the bit time. The data slicer threshold is dynamically adjusted to the midpoint between the carrier-present and no-carrier levels at the summing node for the rectified output of the LF input amplifier.

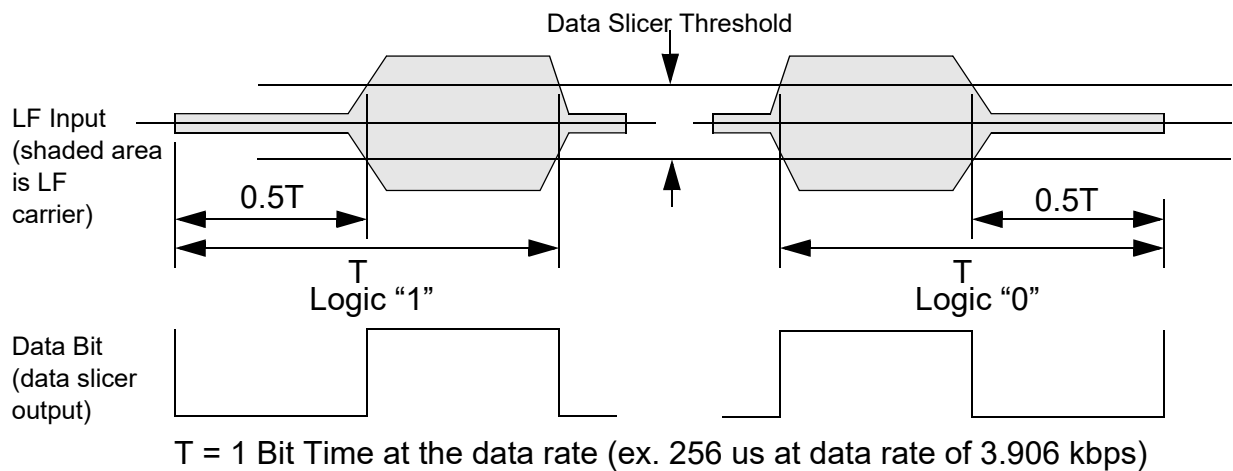

Figure 67. Manchester Encoded Datagram for LFPOL = 0

When the LFPOL bit is set, a logic one bit is defined as LF carrier present for the first half of the bit time; and a logic zero bit is defined as no LF carrier present for the first half of the bit time as shown in Figure 68.

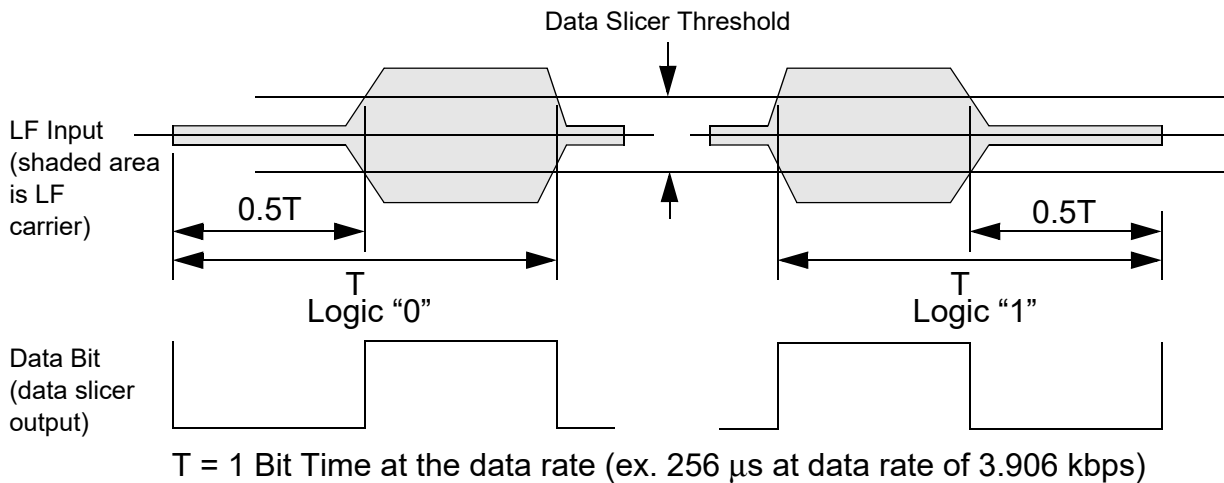

Figure 68. Manchester Encoded Datagram for LFPOL = 1

12.11 Duty-Cycle For Data Mode

The definition of the duty-cycle for the Manchester encoded data depends on the relative rise and fall times of the incoming LF carrier as shown in Figure 69.

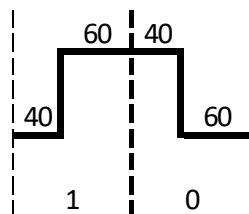

Figure 69. Definition of Duty-Cycle of 40%

Regarding the SYNC pattern which is non-Manchester coded, the duty cycle is applied on all falling edges with the same proportion as a $1T$ Manchester symbol, as shown in Figure 70.

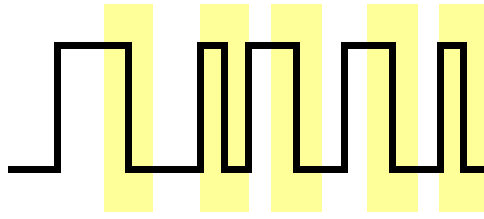

Figure 70. Impact of Duty-Cycle on SYNC Pattern

12.12 Input Signal Envelope

The combination of the external LF antenna and any external components as shown in Figure 71 should not significantly filter the envelope of the LF carrier as shown in Figure 72. Excessive filtering will cause the received message error rate (MER) to increase.

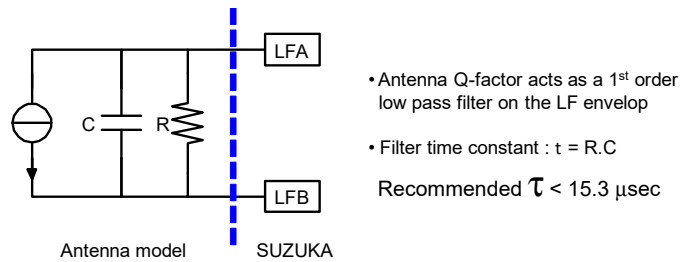
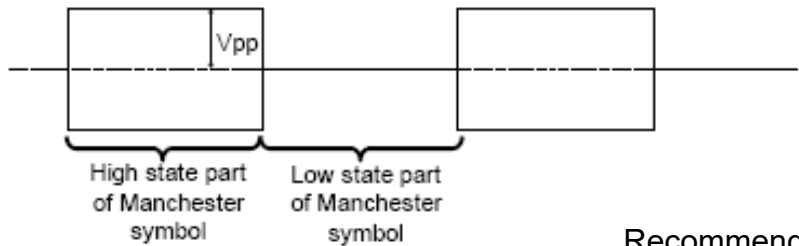

Figure 71. Antenna Q-factor Equivalent Model for the LF Envelope

• Ideal case : $\tau = 0$ (Q-factor = 0)



• Use case : $\tau > 0$ (Q-factor > 0)

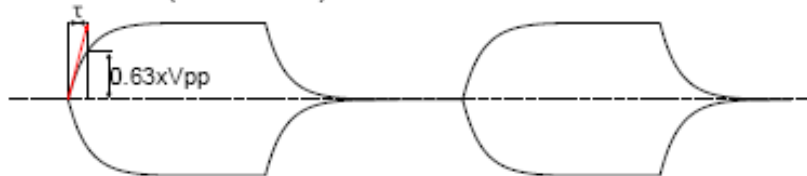

Figure 72. LF Envelope Filtering

12.13 Telegram Verification

The LFR has control bits to allow flexibility in the telegram format and protocol to allow the LFR to adapt to a variety of systems. The LFR can operate in a normal data receive mode where it receives complete telegrams, or in a carrier detect mode where it only checks for a carrier. In the carrier detect mode, as soon as a carrier is detected, the LFCDF flag is set. If LFCDFIE is also set, an interrupt request is sent to wake the MCU

The format of the complete Manchester encoded datagram is comprised of a Manchester data preamble (series of Manchester 1's or 0's), a synchronization period, an optional ID, and zero to n data bytes.

The synchronization period can be used for synchronizing the beginning of the data packet. The SYNC pattern that follows the preamble can be either a 6-, 7.5- or 9 bit-time non-Manchester pattern as shown in [Figure 73](#).

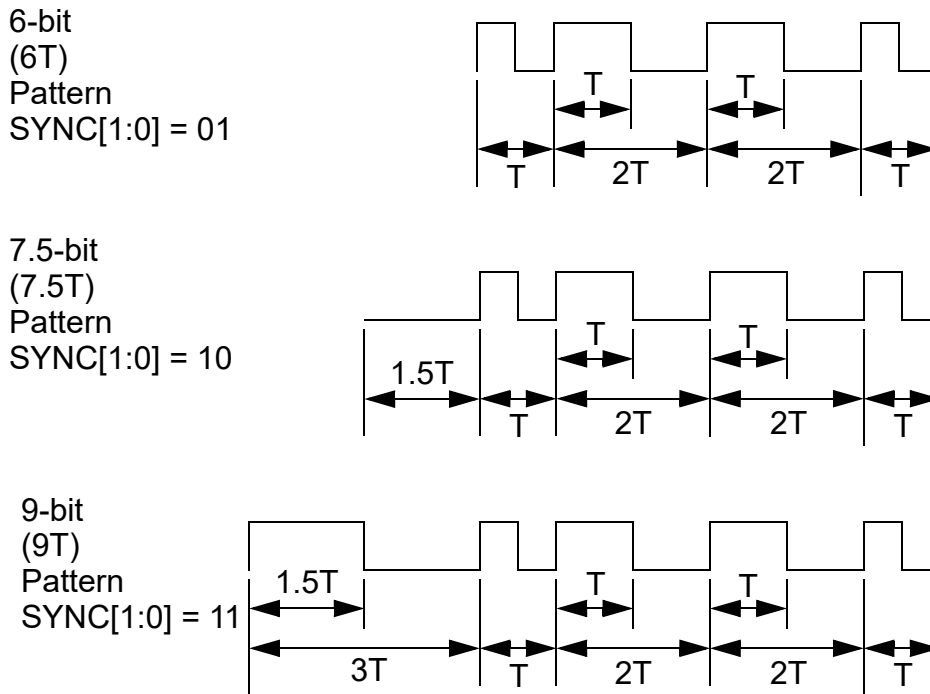

Figure 73. SYNC Patterns

These patterns would normally not appear anywhere in the Manchester encoded portion of a message so there is no possibility that the LFR could accidentally synchronize to a message that was already in progress when the LFR started listening for a message. These patterns are also complex enough so that it is very unlikely that noise or interference could be mistaken for these SYNC patterns. In the data mode and after the detection of a valid carrier, the LFR will decode the data stream waiting for the SYNC word. Should this carrier not be an accepted TPMS type, no SYNC will be received and the LFR module will stay in data receive mode forever. A timeout counter is thus started after a carrier detection and will stop the receiver if reaching the programmed value selected by the TIMOUT[1:0] bits in the LFCTL4 register. This timeout counter is clocked by the internal LFRO clock.

The LFR can be configured to have an optional 0, 8-bit or 16-bit ID after the SYNC pattern. If the ID value matches the received ID, the message is accepted. The ID value can be used to identify a specific receiver, a message type, or some other identifier as defined by application software.

Any number of data bytes can be included after the ID. The LFR begins to assemble data bytes from the incoming signal as soon as the ID check is complete. If the first bit-time after the last bit of the ID does not conform to Manchester coding requirements, the LFR considers the message complete and terminates the LFR operation without setting the data ready flag (LFDRLF). If data follows the ID, it is serially received and when 8 bits have been received the LFR copies this byte into the LFDATA register and sets the LFDRLF flag. If the LFDRIE interrupt enable is also set (and it should be), an interrupt request is sent to wake the MCU so it can read the data and process it according to the instructions in the application program. Additional bytes are received until a bit time that is not Manchester encoded is found. If a non-Manchester bit time is found, the LFERF bit will be set and indicates a Manchester coding error. If this happens on the first bit of the next byte of the message the LFEOMF bit will also be set.

The preamble is a period of Manchester bits before the SYNC pattern as shown in [Figure 74](#). The SYNC pattern will only be matched for the bit times specified by the SYNC[1:0] control bits. Depending on the expected SYNC pattern the allowed preambles is as described for the SYNC[1:0] bits in the LFCTL3 register.

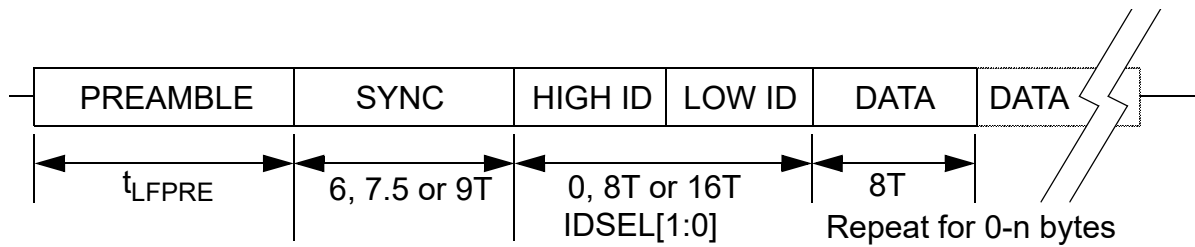

Figure 74. Telegram Format (Carrier Preamble)

12.14 Error Detection and Handling

When the DECEN bit is set, LFR messages are monitored for data rate or SYNC errors, incorrect message ID, and Manchester coding errors. When an error is detected the LFR goes back to sniff mode until the end of ON time completion, if ONMODE is set; or turns off until the start of the next scheduled sampling interval, if ONMODE is cleared. Because the MCU uses more power than the LFR module, it is desirable to keep the MCU in low power standby modes as much as possible. Therefore the handling of these errors will be performed by the LFR and not require additional software processing by the MCU.

When the DECEN bit is clear, there is no monitoring on data. The MCU needs to poll the state of the LFDO bit and create its own decoding scheme within software on the detected signal. To be able to start the polling only when data are received, the carrier detection flag is enabled in data mode when DECEN = 0. During data reception, the auto-zero sequence is performed at each LFO period. The MCU needs also to determine the end of the telegram and turn off the LFR (LFEN = 0) during two LFO cycles before any other operations.

12.15 Continuous ON Mode

In the Continuously ON mode, the LFR module will remain on continuously while the LFEN bit is set. The Continuously ON mode is controlled by setting the LFSTM[3:0] bits.

In the Continuously ON mode, if a signal is successfully processed by the digital, the LFR module will stop and restart automatically. The gap is 2-3 LFO periods. Also if TOGMOD bit is set, the LFR module will stop after the ON time cycle and restart automatically, after having changed the CARMOD bit.

12.16 Initialization Information

When power is applied to the MCU, the LFR must be initialized and configured before it can begin to receive LF messages. Several systems in the LFR require factory trimming to ensure operation within specified limits. After these trim values are written, they remain constant until the next MCU reset.

The application program must set up control bits and registers to configure the LFR to determine the structure of the message telegram, the input sensitivity, and other LFR options. It is good practice to clear the flags in the LFS register before enabling interrupt sources in order to avoid any immediate interrupt requests.

12.17 LFR Register Definition

The LFR module uses eight addresses in the MCU memory map for data, control, and status registers. This section consists of register descriptions. Each control register (LFCTLx) should be modified when the LF is off (LFEN = 0). Modification of the control registers “on-the-fly” might lead to unknown state. Each turn off of the LFR (LFEN = 0) should be followed by at least two LFO cycles before trying to restart the LFR (LFEN = 1).

12.17.1 LF Control Register 1 (LFCTL1)

LFCTL1 contains the main LF enable control, detection protocol format controls, and input sensitivity controls. The LFCTL1 register also contains a register select bit, LPAGE.

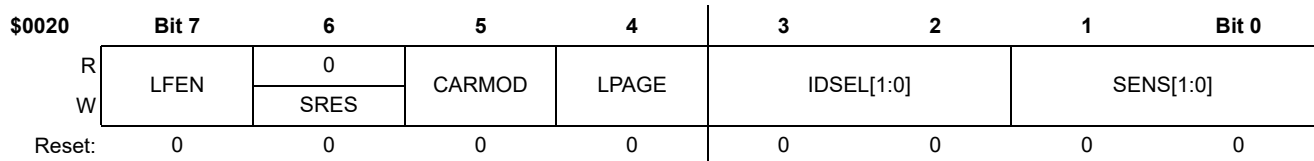

Figure 75. LFR Control Register 1 (LFCTL1)

Table 59. LFCTL1 Register Field Descriptions

Field	Description
7 LFEN	LF Enable — This read-write control bit is used to enable or disable the LF receiver. Once this bit is set the LFR will go through a power-up sequence that starts on the next rising edge of the LFO clock. The first complete cycle of the LFO is used to power up the LFR circuits. Following this startup time the auto-zero sequence is performed for 64 μ sec and then the LFR is ready to receive signals. 0 LF receiver in standby. 1 LF receiver active. Note: Enabling the LF receiver function disables the GPIO Port B functions - see Section 6.5 .
6 SRES	Soft Reset — This read/write bit controls the soft reset of the LFR. The bit is self reset and always reads as a logical zero. 0 Reset completed 1 Start a soft reset.
5 CARMOD	Carrier Mode — This read/write control bit selects the basic operating mode for the LFR. 0 Data receive mode. 1 Carrier detect mode - wake the MCU when a carrier signal is detected if LFC DIE is set.
4 LPAGE	LFR Page Select — This read/write bit is used to select the register page access. The LPAGE bit has no effect on the LFCTL1 and LFCTL2 registers. This bit is cleared by LFR reset. 0 Access page 0. 1 Access page 1.
3:2 IDSEL[1:0]	Wakeup ID Selection — Selects the existence and length of the wakeup ID. Reset clears these bits. 00 No ID expected 01 8-bit ID based on the contents of the LFIDL register 10 16-bit ID based on the contents of the LFIDH and LFIDL registers 11 8-bit ID matches the contents of either the LFIDH or LFIDL registers
1:0 SENS[1:0]	Sensitivity Control — These two read/write control bits select the sensitivity thresholds for the LFR input. These thresholds apply to the detection portion of a message. If the input level is below the S_{NODET_X} level, no signal will be detected. If the level is above S_{DET_X} , the signal will be detected. Sensitivity settings are only used in the carrier detect path and do not affect reception of the message body. 00 Performance not specified. 01 Low sensitivity (S_{DET_L} ; S_{NODET_L}) 10 High sensitivity (S_{DET_H} ; S_{NODET_H}) 11 Performance not specified.

12.17.2 LF Control Register 2 (LFCTL2)

LFCTL2 contains the selection bits for the length of the LF sampling ON time and the time interval between samples as shown in Figure 76.

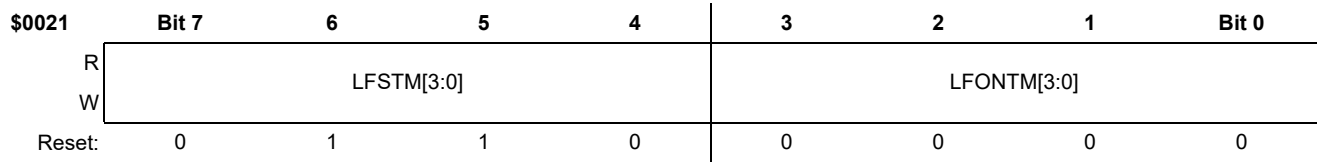

Figure 76. LFR Control Register 2 (LFCTL2)

Table 60. LFCTL2 Register Field Descriptions

Field	Description
7:4 LFSTM [3:0]	<p>LF Sampling Time Interval Select— These read/write control bits select the length of time between when the LFR input detector is turned on as set by the LFONTM bits in LFCTL2 register. The initial sampling interval starts with the LFO clock following a write to these bits. A reset of the LFR results in the value being set to binary 0110.</p> <p>0000 Continuous ON mode (see Section 12.15)</p> <p>0001 Sampled decoding mode every 16 LFO clock periods (16 milliseconds nominal)</p> <p>0010 Sampled decoding mode every 32 LFO clock periods (32 milliseconds nominal)</p> <p>0011 Sampled decoding mode every 64 LFO clock periods (64 milliseconds nominal)</p> <p>0100 Sampled decoding mode every 128 LFO clock periods (128 milliseconds nominal)</p> <p>0101 Sampled decoding mode every 256 LFO clock periods (256 millisecond nominal)</p> <p>0110 Sampled decoding mode every 512 LFO clock periods (512 milliseconds nominal)</p> <p>0111 Sampled decoding mode every 1024 LFO clock periods (1024 milliseconds nominal)</p> <p>1000 Sampled decoding mode every 2048 LFO clock periods (2048 milliseconds nominal)</p> <p>1001 Sampled decoding mode every 4096 LFO clock periods (4096 milliseconds nominal)</p> <p>1010-1xxx Continuous ON mode (see Section 12.15)</p>
3:0 LFONTM [3:0]	<p>LF Sampling ON Time Select — These read/write control bits select the length of time that the LFR input detector is turned on at the beginning of each sampling interval set by the LFSTM bits. This ON time is the net sampling time with any initialization time (maximum of 2 ms) included in the OFF time prior to the sample ON time (see Figure 77). If a signal is successfully detected, the length of time the detector remains ON depends on the operating mode. In carrier detect mode (CARMOD = 1) the detector will be turned off early if the evaluation of the carrier signal is completed before the end of the scheduled ON time. In data receive mode (CARMOD = 0) the detector will remain ON until the end of the message, an error is detected or timeout occurrence. Reset forces the LFONTM bits to 0:0:0.</p> <p>0000 1 LFO clock cycle (1 millisecond nominal)</p> <p>0001 2 LFO clock cycle (2 milliseconds nominal)</p> <p>0010 4 LFO clock cycle (4 milliseconds nominal)</p> <p>0011 8 LFO clock cycle (8 milliseconds nominal)</p> <p>0100 16 LFO clock cycle (16 milliseconds nominal)</p> <p>0101 32 LFO clock cycle (32 milliseconds nominal)</p> <p>0110 64 LFO clock cycle (64 milliseconds nominal)</p> <p>0111 128 LFO clock cycle (128 milliseconds nominal)</p> <p>1000 256 LFO clock cycle (256 milliseconds nominal)</p> <p>1001 512 LFO clock cycle (512 milliseconds nominal)</p> <p>1010 1024 LFO clock cycles (1024 milliseconds nominal)</p> <p>1011 1024 LFO clock cycles (1024 milliseconds nominal)</p> <p>11xx 1024 LFO clock cycles (1024 milliseconds nominal)</p> <p>Note: The LFONTM selected time must be less than the LFSTM selected time, otherwise the Continuously ON mode is present.</p>

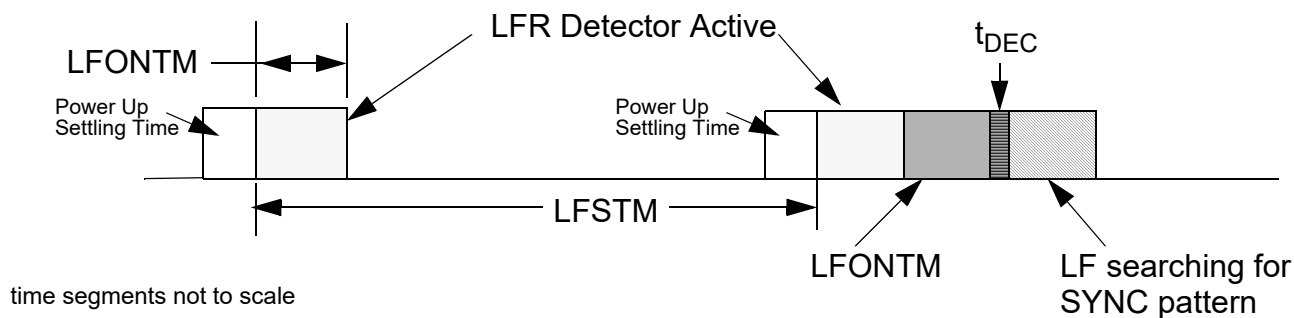

Figure 77. LF Detector Sampling Timing

12.17.3 LF Control Register 3 (LFCTL3)

LFCTL3 contains the control bits for the LF sampling interval and the minimum required carrier detection time when using the carrier detect mode.

\$0022	Bit 7	6	5	4	3	2	1	Bit 0
R	LFDO	TOGMOD	SYNC[1:0]		LFCDTM[3:0]			
W								
Reset:	—	0	0	1	0	0	0	0
		= Reserved						

Figure 78. LFR Control Register 3 (LFCTL3)

Table 61. LFCTL3 Register Field Descriptions

Field	Description
7 LFDO	LF Detector Output — This read-only bit follows the bit slicer output signal that goes high during the presence of a carrier. It may change at any time. This bit is read only and unaffected by any reset. 0 LF detector output low (no signal above threshold) 1 LF detector output high (received signal above threshold)
6 TOGMOD	LFR Mode Toggle — This read/write bit enables the toggling of the CARMOD bit at each new LFON sequence. Reset clears this bit. 0 CARMOD bit does not change and determines detector mode. 1 CARMOD bit will be toggled every LFON detection sequence, starting by CARMOD selection. Therefore the reception chain will alternately look for a carrier frame or for a data frame.
5:4 SYNC[1:0]	LF SYNC Selection — Selects the type of SYNC pattern as described in Figure 73 . Reset presets these bits to the 01 (6T SYNC) option. Compatible with preamble consisting of minimum 2 ms Manchester data to allow for proper averaging filter operation. 00 For factory test purposes, not intended for use in any application. 01 6T SYNC pattern 10 7.5T SYNC pattern 11 9T SYNC pattern

Table 61. LFCTL3 Register Field Descriptions (continued)

Field	Description
<p>3:0 LFCDTM [3:0]</p>	<p>LF Carrier Detect Time — These read/write control bits select the length of time which the LFR input detector must detect a carrier before validating it. In carrier mode (CARMOD = 1), if the carrier is active for at least the time selected by the LFCDTM[3:0] bits and the LFCC counter value is reached, the LFCDF flag in the LFS register will be set; and if the LFCDIE control bit is also set, the MCU will be interrupted (wake-up).</p> <p>In the data receive mode (CARMOD = 0) the LFCDTM[3:0] bits select the length of time which the LFR input detector must detect a carrier before the effective receive chain is powered on. Once the carrier has been validated the LFCDTM[3:0] bits ignored during the decode of the rest of the data.</p> <p>Reset of the LFR results in LFCDTM[3:0] being reset to 0:0:0:0. The resulting carrier detect times are defined by the following number of carrier periods needed to validate the carrier, with the corresponding time for a carrier at 125 kHz in parenthesis:</p> <p>0000 Carrier detect = 8 (64 μsec) Data mode detect = 8 (64 μsec) 0001 Carrier detect = 16 (128 μsec) Data mode detect = 8 (64 μsec) 0010 Carrier detect = 32 (256 μsec) Data mode detect = 8 (64 μsec) 0011 Carrier detect = 64 (512 μsec) Data mode detect = 8 (64 μsec) 0100 Carrier detect = 128 (1024 μsec) Data mode detect = 8 (64 μsec) 0101 Carrier detect = 256 (2048 μsec) Data mode detect = 8 (64 μsec) 0110 Carrier detect = 512 (4096 μsec) Data mode detect = 8 (64 μsec) 0111 Carrier detect = 1024 (8192 μsec) Data mode detect = 8 (64 μsec)</p> <p>1000 Carrier detect = 8 (64 μsec) Data mode detect = 8 (64 μsec) 1001 Carrier detect = 16 (128 μsec) Data mode detect = 16 (128 μsec) 1010 Carrier detect = 32 (256 μsec) Data mode detect = 32 (256 μsec) 1011 Carrier detect = 64 (512 μsec) Data mode detect = 64 (512 μsec) 1100 Carrier detect = 128 (1024 μsec) Data mode detect = 128 (1024 μsec) (see note) 1101 Carrier detect = 256 (2048 μsec) Data mode detect = 256 (2048 μsec) (see note) 1110 Carrier detect = 512 (4096 μsec) Data mode detect = 512 (4096 μsec) (see note) 1111 Carrier detect = 1024 (8192 μsec) Data mode detect = 1024 (8192 μsec) (see note)</p>

NOTE

The auto-zero sequence needs to be performed every 1 ms. Therefore LFR detection times of 1024, 2048, 4096 and 8192 μsec the auto-zero sequence will be done at each 1 ms interval. This auto-zero sequence lasts for 64 μsec. If the carrier is detected again at the end of the auto-zero sequence it is assumed that the carrier was there for the complete 64 μsec period of the auto-zero.

12.17.4 LFR Control Register 4 (LFCTL4)

LFCTL4 contains local interrupt enable control bits. The provided I-interrupts are not globally masked by the I bit in the CPU's CCR, setting one or more of these interrupt enable control bits will cause a CPU interrupt to be requested whenever the flag bit associated with the corresponding LFR interrupt source becomes set. It is good practice to clear any flag bits in the LFS register before setting interrupt enable bits in this register in order to avoid an immediate interrupt request.

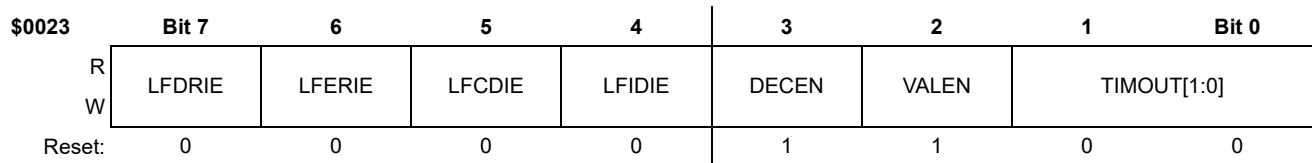

Figure 79. LFR Control Register 4 (LFCTL4)

Table 62. LFCTL4 Register Field Descriptions

Field	Description
7 LFDRIE	LFR Data Register Full Interrupt Enable — This read/write bit enables interrupts to be requested when the LFR data register is full. Reset clears LFDRIE. 0 LFDRIE interrupts disabled. Use software polling. 1 LFR Data Register Full interrupts are enabled. If LFDRIE is set, then an interrupt is requested when LFDRIE = 1.
6 LFERIE	LFR Error Interrupt Enable — This read/write bit enables interrupts to be requested when the LFR detects an error in reception of a non-Manchester encoded bit time following the SYNC time. Reset clears LFERIE. 0 LFERIE interrupts disabled. Use software polling. 1 LFERIE interrupts are enabled. If LFERIE is set, then an interrupt is requested when LFERIE = 1.
5 LFC DIE	LFR Carrier Detect Interrupt Enable — This read/write bit enables the LFCDF interrupt when the LFR detects the number of samples with an LF signal defined by the LFCDTM bits in the LFCTL3 register. The LFC DIE is ignored when the LFR is operating in the data mode (CARMOD = 0), except when DECEN is cleared. Reset clears LFC DIE. 0 LFCDF interrupts disabled. 1 LFR LFCDF interrupts are enabled. If LFC DIE is set, then an interrupt is requested when LFCDF = 1.
4 LFIDIE	LFR ID Detect Interrupt Enable — This read/write bit enables interrupts to be requested when the LFR detects a match to the ID code selected in the LFIDH:L registers. Reset clears LFIDIE. 0 LFIDIE interrupts disabled. 1 LFIDIE interrupts are enabled. If LFIDIE is set, then an interrupt is requested when LFIDIE = 1.
3 DECEN	LF Digital Decode Enable — This read/write bit enables the data processing by the digital decoder. When disabled, the frame format (Manchester, data-rate, SYNC, data) is not checked. There is no more error flag assertion (data, error, ID). The MCU should then poll the LFDO bit to extract from the analog detector the bit stream. Reset sets the DECEN bit. 0 Digital decoder is disabled. 1 Digital decoder is enabled.
2 VALEN	LF Validation Enable — This read/write bit enables the carrier validation process. Reset sets this bit. 0 Carrier Validation disabled. 1 Carrier Validation enabled.
1:0 TIMOUT [1:0]	SYNC Time Out Select — These two read/write bits select the period of time that the LFR will search for a SYNC pattern in the data mode. If the SYNC pattern is not detected the LFR will be turned off after this delay time. These time intervals are clocked by the internal LFRO clock. Reset clears TIMOUT bit. 00 SYNC word is continuously searched — no timeout. 01 SYNC search time set to nominal 8 milliseconds. 10 SYNC search time set to nominal 24 milliseconds. 11 SYNC search time set to nominal 48 milliseconds.

12.17.5 LFR Status Register (LFS, LPAGE = 0)

LFS contains the data ready status flags. It is only accessible when the LPAGE bit is clear.

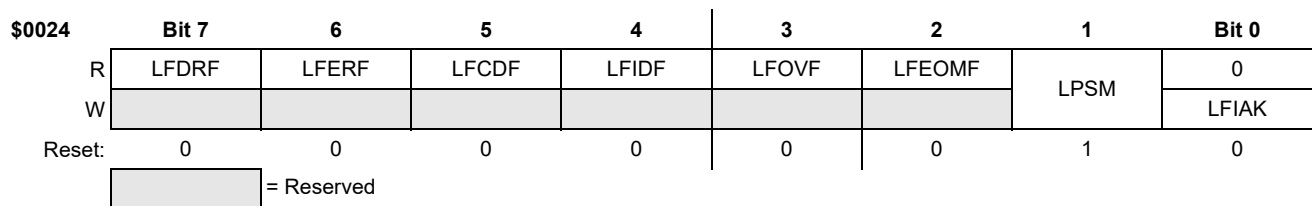

Figure 80. LFR Status Register (LFS, LPAGE = 0)

Table 63. LFS Register Field Descriptions

Field	Description
7 LFDRF	LF Data Ready Flag — This read-only status flag is set when a complete byte of data has been received by the LFR. An interrupt is sent to the MCU if the LFDRIE bit is set. Clear LFDRF by writing a one to the LFIK bit or reading the LFDATA register. LFDRF is also cleared by reset. 0 No new data in LFDATA register. 1 A new byte of data has been received and can be read from the LFDATA register.
6 LFERF	LF Receive Error Flag — In data receive mode, this read-only status flag is set when a non-standard bit time is detected in the Manchester data mode. Any received data bits before the error occurs are placed in the data buffer. In carrier detect mode, this read-only status flag is not used and remains clear. An interrupt is sent to the MCU if the LFERIE bit is set. Clear LFERF by writing a one to the LFIK bit. LFERF is also cleared by reset. 0 Normal operation. 1 Error detected in the Manchester data mode.
5 LFDCF	LF Carrier Pulse Detect Flag — In carrier detect mode, this read-only status flag is set when the number of consecutive carrier validations set by the LFCC bits in is reached. Note that the LFCC function is not working if TOGMOD = 1. Clear LFDCF by writing a one to the LFIK bit. LFDCF is also cleared by reset. 0 Normal operation. 1 Carrier detection has occurred.
4 LFIDF	LF ID Detect Flag — In data receive mode, this read-only status flag is set when the received ID matches the stored value. This interrupt can be generated even if no data bits follow the ID. An interrupt is sent to the MCU if the LFIDIE bit is set. Clear LFIDF by writing a one to the LFIK bit. LFIDF is also cleared by reset. 0 Normal operation. 1 wakeup ID has been detected.
3 LFOVF	LF Receive Data Overflow Flag — In data receive mode, this read-only status flag is set when a complete byte of data has been received and written into the LFDATA register, but the previously received byte was not read from LFDATA register yet. This indicates that the MCU has lost the previously received data byte. In carrier detect mode, this read-only status flag is not used and remains clear. No separate interrupt is generated by this specific flag bit because the LFDRF flag would serve that purpose. Clear LFOVF by writing a one to the LFIK bit. LFOVF is also cleared by reset. 0 Normal operation. 1 Previous data over-written before MCU read it.
2 LFEOMF	LF Receive Data EOM Flag — In data receive mode, this read-only status flag is set when a complete byte of data has been received and written into the LFDATA register and an end-of-message Manchester encoding error occurs. In carrier detect mode, this read-only status flag is not used and remains clear. No interrupt is generated by this flag bit because the LFERF flag would serve that purpose. Clear LFEOMF by writing a one to the LFIK bit. LFEOMF is also cleared by reset. 0 No EOM detected. 1 EOM detected.
1 LPSM	Low Power Sniff Mode — This bit used to activate the low power consumption during SNIFF mode. It saves approximately 1 μ A with a trade-off of an additional 200 μ s in transition from carrier to data mode. LPSM is set by reset. 0 Low time transition from carrier to data mode 1 Low consumption during sniff mode
0 LFIK	LF Interrupt Acknowledge — Writing a one to the LFIK bit clears the LFDRF, LFERF, LFDCF, LFIDF, LFOVF and LFEOMF flag bits. When a one is written to the LFIK, it is automatically cleared at the next positive edge of the MCU bus clock. Then, reading the LFIK bit is allowed but will always return zero. Writing a zero the LFIK bit has no effect. Reset has no effect on this bit. 0 No effect. 1 Clears the LFDRF, LFERF, LFDCF, LFIDF, LFOVF and LFEOMF flag bits.

12.17.6 LFR Data Register (LFDATA, LPAGE = 0)

The LFDATA is a read-only register that contains the most recent received data value. It is only accessible when the LPAGE bit is clear. As data is serially received by the LFR, it is assembled into 8-bit values. When a new complete 8-bit value is received, it is moved into the LFDATA register, over-writing any previous value, and the LFDRF data ready flag is set to indicate a value is available for the MCU to read. If a previous value was ready but was not read out of the LFDATA register before a new data byte is ready, the LFOVF overflow flag is also set to indicate this overflow condition. Writes to LFDATA have no meaning or effect.

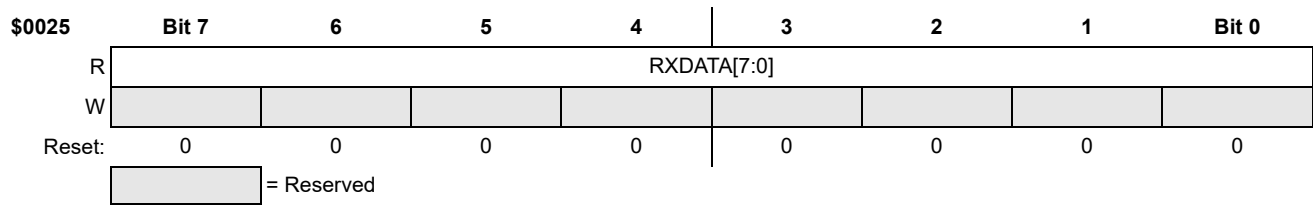

Figure 81. LFR Data Register (LFDATA) when LPAGE = 0

Table 64. LFDATA Register Field Descriptions

Field	Description
7:0 RXDATA [7:0]	Receive Data [7:0] — This is the received data from the LFR when in the data mode. All bits are read-only and any writes to these bits will be ignored. Reading this register will clear the LFDRF.

12.17.7 LFR ID Registers (LFIDH:LFIDL, LPAGE = 0)

These two 8-bit read/write registers hold one of two ID values for LF messages. They are only accessible when the LPAGE bit is clear. The type of ID checking can be selected or disabled by using the IDSEL[1:0] bits in the LFCTL1 register. When ID checking is enabled, the ID value received through the LFR must match the contents of the LFIDH and/or LFIDL registers depending on the IDSEL bits or the message will be ignored and the MCU will remain in standby mode to minimize power consumption. All these bits are cleared by a reset.

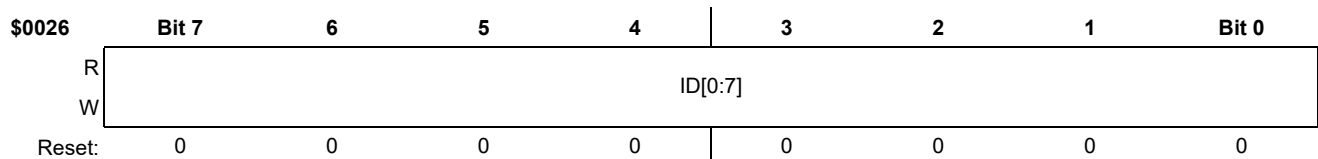

Figure 82. LFR ID Low Byte (LFIDL)

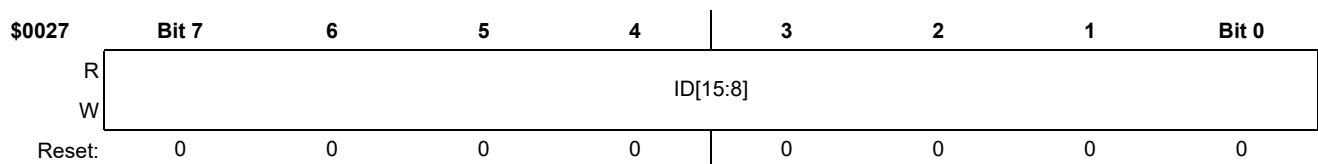

Figure 83. LFR ID High Byte (LFIDH)

Table 65. LFR ID Register Field Description

Field	Description
ID[15:0]	ID bits 15 through 0 — These read/write bits contain bits 15 through 0 of the 16-bit ID value.

12.17.7.1 LF Control E - LFCTRLE

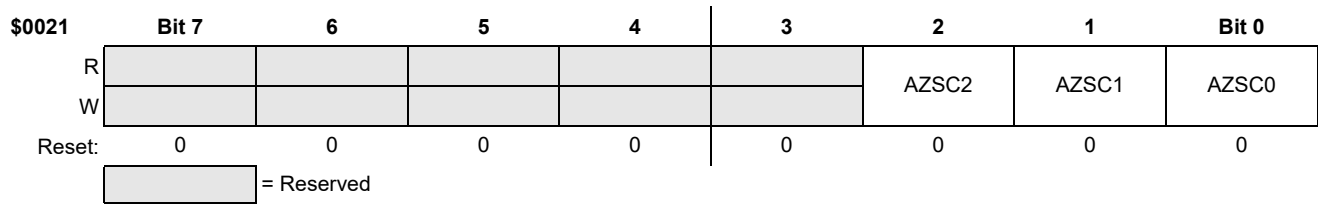

Figure 84. LF Control E (LFCTRLE)

Table 66. LFCTRLE Register Field Description

Field	Description
7-3 Reserved	Reserved bits — Not for user access.
2-0 AZSC	LOGAMP AZ Sequencer Control — Control bits for AZ and trim within the LOGAMP. X00 Nominal AZ sequence - recommended setting X01 Short amp output release, max delay with Rects X10 Short amp output release, max delay with Amp input X11 All short, max delay with end of AZ 0XX Nominal sensitivity trim - recommended setting 1XX Sensitivities shifted by - 4 trim steps

12.17.8 LFR Control Register D (LFCTRLD, LPAGE = 1)

The LFCTRLD register contains two control bits for the LF detector and decoder. It is only accessible when the LPAGE bit is set.

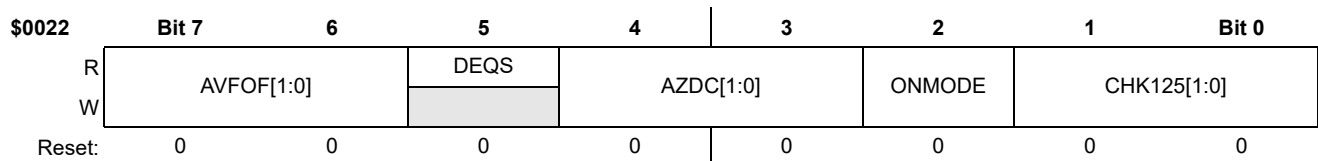

Figure 85. LFR Control Register D (LFCTRLD, LPAGE = 1)

Table 67. LFCTRLD Register Field Descriptions

Field	Description
7-6 AVFOF [1:0]	SUM AZ release delay — Control the delay between falling edge of SUM d_az_en input and falling edge of internal AZ control line. 00 No delay 01 No delay 10 One-half of 125 kHz clock period delay - recommended setting 11 One and one-half of 125 kHz clock periods delay
5 DEQS	DeQing status register — This read-only status bit allows the reading of the effective activation of the DeQing System. 0 DeQing system not activated 1 DeQing system activated
4-3 AZDC [1:0]	AZ Digital Control of AZ triggering — In data receive mode, this bits control the triggering of AZ sequence with respect to both LFCPTAZ value (ref. LFCTRLB register) and the state of the demodulation input data state. 00 AZ starts after LFCPTAZ numbers of input data edges. 01 Z starts randomly adding -1, 0 or 1 to LFCPTAZ value between each AZ. 10 AZ starts after LFCPTAZ numbers of input data edges and when the input data (d_data) state is 0. 11 AZ starts after LFCPTAZ numbers of input data edges and when the input data (d_data) state is 1 - recommended setting.
2 ONMODE	ON Behavior Mode — This read/write bit selects how an error will affect the ON time. This bit is cleared by reset. 0 Any error will stop the ON time. 1 If remaining ON time, the LFR will go back to sniff mode at any error - recommended setting.

Table 67. LFCTRLD Register Field Descriptions (continued)

Field	Description
1-0 CHK125 [1:0]	Accurate 125 kHz Check — The bit controls the CARVAL frequency check method.
	00 CARVAL validates on n (2*32 μs packets), n depending on LFCDTM value - recommended setting for Low Sensitivity mode.
	01 CARVAL validates on n (1*32 μs packet + 4*8 μs packets), n depending on LFCDTM value - optional recommended setting for High Sensitivity mode.
	10 CARVAL validates on n (8*8 μs packet), n depending on LFCDTM value - optional recommended setting for High Sensitivity mode.
11	Same as 00.

NOTE

Setting CHK125[1:0] to either 0x01 or 0x10 increases the immunity to noise and therefore carries the side effect of narrowing the 125 kHz carrier bandwidth tolerance.

12.17.9 LFR Control Register C (LFCTRLC, LPAGE = 1)

The LFCTRLC register contains control bits for the LF detector and decoder. It is only accessible when the LPAGE bit is set.

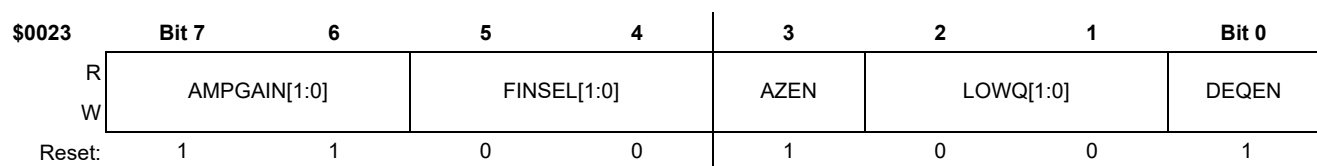

Figure 86. LFR Control Register C (LFCTRLC, LPAGE = 1)

Table 68. LFCTRLC Register Field Descriptions

Field	Description
7-6 AMPGAIN [1:0]	3rd Amplifier gain — These bits controls the 3rd amplifier gain.
	00 Gain of 2 - recommended setting
	01 Gain of 3
	10 Gain of 4
11	Gain of 6
5-4 FINSEL [1:0]	Final stage select — These bits select the final stage of the LOGAMP.
	00 Continuous time biasing - Fixed Gain 6
	01 Continuous time biasing - Programmable Gain - recommended setting
	10 4th rectifier disabled
11	4th rectifier disabled
3 AZEN	Data AZ enable — This bit allows the AZ sequence during data frame.
	0 AZ during data disabled
	1 AZ during data enabled - recommended setting
2-1 LOWQ [1:0]	DeQing Resistor — These bits select the resistor added in parallel to the input network.
	00 4 kΩ
	01 2 kΩ
	10 1 kΩ
11	500 Ω
0 DEQEN	DeQing System enable — The bit controls the DeQing system.
	0 DeQing disabled.
	1 DeQing enabled.

12.17.10 LFR Control Register B (LFCTRLB, LPAGE = 1)

The LFCTRLB register contains control bits for the LF detector and decoder. It is only accessible when the LPAGE bit is set.

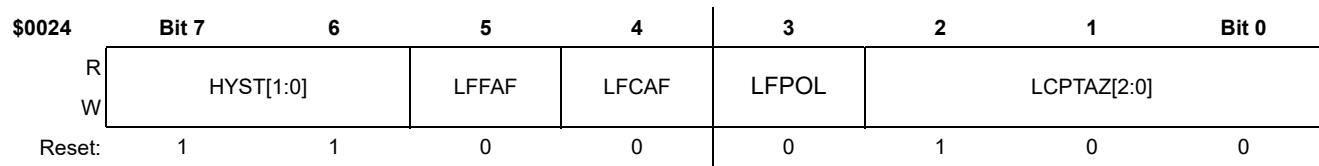

Figure 87. LFR Control Register B (LFCTRLB, LPAGE = 1)

Table 69. LFCTRLB Register Field Descriptions

Field	Description
7-6 HYST [1:0]	Control slicer hysteresis 00 20 mV hysteresis 01 40 mV hysteresis 10 50 mV hysteresis 11 30 mV hysteresis - recommended setting
5-4 LFFAF; LFCAF	Average filter bi-phase filtering control — Activates bi-phase filtering and control offset value 00 Standard low pass filtering activated - recommended setting 01 Standard low pass filtering activated 10 Bi-phase filtering activated - Low offset from input signal low level 11 Bi-phase filtering activated - High offset from input signal low level
3 LFPOL	LF Manchester Polarity Select — This read/write bit selects the polarity of the transition in the middle of the bit time. The LFPOL is not used in Carrier mode. Reset clears LFPOL bit. 0 Zero is falling edge in middle of a bit time, one is a rising edge in the middle of bit time. 1 Zero is rising edge in middle of a bit time, one is a falling edge in the middle of bit time.
2-0 LCPTAZ [2:0]	LF auto-zero counter — Applications to set these bits to 0x06 for proper LF operation. These bits tune the minimum number of data edges between two auto-zero requests during a data frame.

12.17.11 LFR Control Register A (LFCTRLA, LPAGE = 1)

The LFCTRLA register contains control bits for the LF detector and factory test selects. It is only accessible when the LPAGE bit is set.

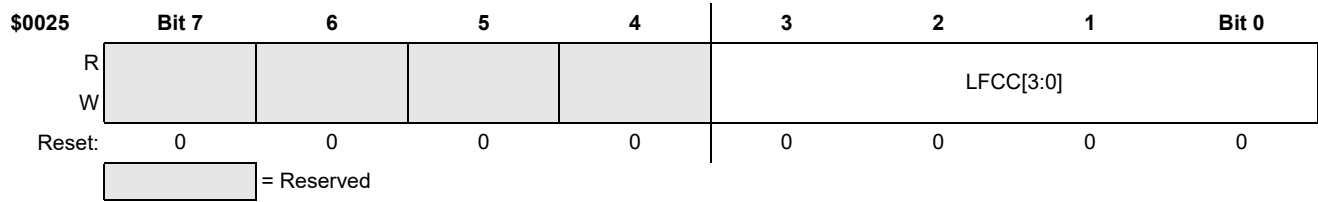

Figure 88. LFR Control Register A (LFCTRLA, LPAGE = 1)

Table 70. LFCTRLA Register Field Descriptions

Field	Description
7-4 Reserved	Reserved bits — Not for user access.
3-0 LFCC [3:0]	<p>LF Successive Carrier Validations Counter — The value of the LFCC[3:0] bits define how many times the carrier detect sample ON time detected an LF carrier signal before the LFCDF flag bit set. The flag will be risen when the number of ON samples with a detected carrier greater than the LFCDTM[3:0] reaches the value of the LFCC[3:0] bits plus one. The internal count of detected carrier pulses will increment the count as long as they are consecutive samples. When a sample is encountered without any detected carrier the count will be reset.</p> <p>The LFCC register is considered reset in data mode. The first carrier validation will lead to start up of the receiver chain.</p> <p>This feature allows the user to define a number of consecutive carrier detections are required before the flag is risen; and is useful in detecting long duration carrier pulses.</p> <p>This counter is disabled if TOGMOD = 1.</p>

13 RF Module

It is not intended that the RFM may be actively powered up and/or transmitting RF data while physical parameter measurements are being made; or during the time that the LFR may be actively receiving/decoding LF signals. The resulting interactions will degrade the performance of the RF output spectrum.

The FXTH870x6 consists of an RF module (RFM) with external crystal-driven oscillator, VCO, fractional-n PLL and RF output amplifier (PA) for an antenna. It also contains a small state machine controller, random time generator and hardware data buffer for automated output or direct control from the MCU. The overall block diagram is shown in [Figure 89](#).

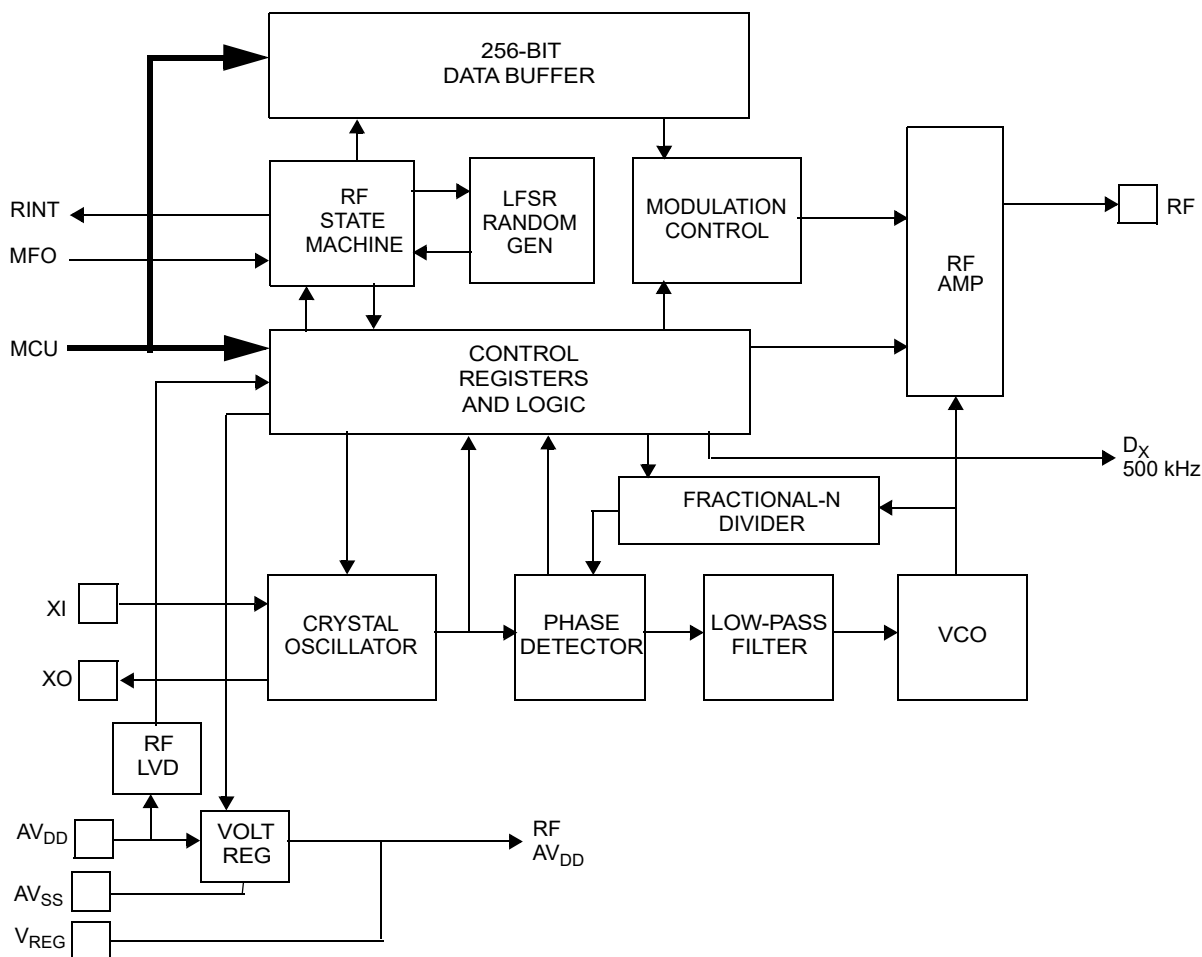

Figure 89. RF Transmitter Block Diagram

13.1 RF Data Modes

There are two modes of operation in using the RF output in either the data buffer mode or MCU direct mode.

13.1.1 RF Data Buffer Mode

In the RF data buffer mode the transmissions are sent by dedicated logic hardware while the MCU can be put into a low power mode until the transmission is completed. This RF state machine is clocked by the MFO which is enabled when the SEND bit is set and when any of the LFR, SMI or MCU are operating.

The RF data buffer consists of a dedicated RFM state machine and a 256-bit data buffer. The RF data buffer is loaded with whatever data pattern the user software creates. The number of data bits to be sent is selected by the FRM[7:0] control bits. The control logic is triggered by the SEND control bit when it is time to transmit the data which is sent to the RF stage after being encoded as either Manchester, Bi-Phase or NRZ data according to the method selected by the CODE[1:0] bits as described in [Section 13.17](#).

Before the data can be transmitted the RFM control logic enables the external crystal oscillator and phase-locked-loop to initialize before the RF output stage can begin transmission.

The external crystal connected to the X0 and XI pins provides the carrier frequency as well as the data rate clock needed for the data rates associated with the OOK or FSK modulation. Therefore the tolerance on the data rate will depend on the characteristics of the external crystal.

Once the data buffer is emptied the data transfer stops; the RF output stage is turned off; and the SEND control bit is cleared and an interrupt of the MCU may be generated to wake it from the STOP1 mode. The user can test that the transmission has completed by reading back the state of the SEND control bit or the RFIF status bit.

There is also the option to send the same data frame from 1 to 16 times with interlaced time intervals when the RF transmitter PA output stage is off. If multiple frames of data are to be transmitted within a datagram the spacing before the first frame and between subsequent frames can be controlled by the RFM state machine in several ways:

1. Use of a programmable timer (random, base time, time adder).
2. No time delays.

In addition, the RFM crystal oscillator, VCO and PLL can be turned off during any interframe timing by use of the IFPD bit.

When using the data buffer mode the user's software should not change any bits in the RFM registers after the SEND has been set and the transmission is still in progress. Changing RFM register contents during a transmission can lead to data faults or errors.

13.1.2 MCU Direct Mode

When the CODE[1:0] bits are both set the encoding is controlled directly by the MCU where the data to the RF output depends on the state of the DATA bit and the selected modulation scheme. In this mode the user software must control the RF output stage to power up (using the SEND control bit), WAIT for the RF output stage to stabilize (monitor the RCTS status bit) and clock the DATA to the RF output stage. In this mode the data rate and its stability will depend on the internal HFO oscillator.

Any transfers of data from the MCU will use the DATA bit which will be reflected as modulated data on the RF pin once the RF output stage is set up to transmit. The maximum data rate in this mode will depend on the complexity of the user software and the MCU clock rate.

The POL bit in this case simply inverts the state of the DATA bit before it drives the RF output stage.

The accuracy of the data rate in the MCU direct mode is directly dependant on the HFO accuracy.

13.2 RF Output Buffer Data Frame

When using the RF data buffer mode each frame of data is sent as 2 to 256 bits per frame with a possible two trailing bits for an end-of-message, EOM, as shown in [Figure 90](#). The actual data being transmitted in a given data frame and any combinations of data frames into a single datagram is dependent on the user software.

The number of frames sent in a given datagram can be from 1 to 16 based on the FNUM[3:0] bits in the RFCR3. The 256-bit buffer is divided into two pages of 128 bits as selected by the RPAGE bit in the RFCR2.

The data buffer is unloaded to the RF output starting with the least significant bit (RFD0) in the least significant byte (RFB0) up through the most significant bit (RFD127) in the most significant byte (RFB15). This is often referred to as "little-endian" data ordering.

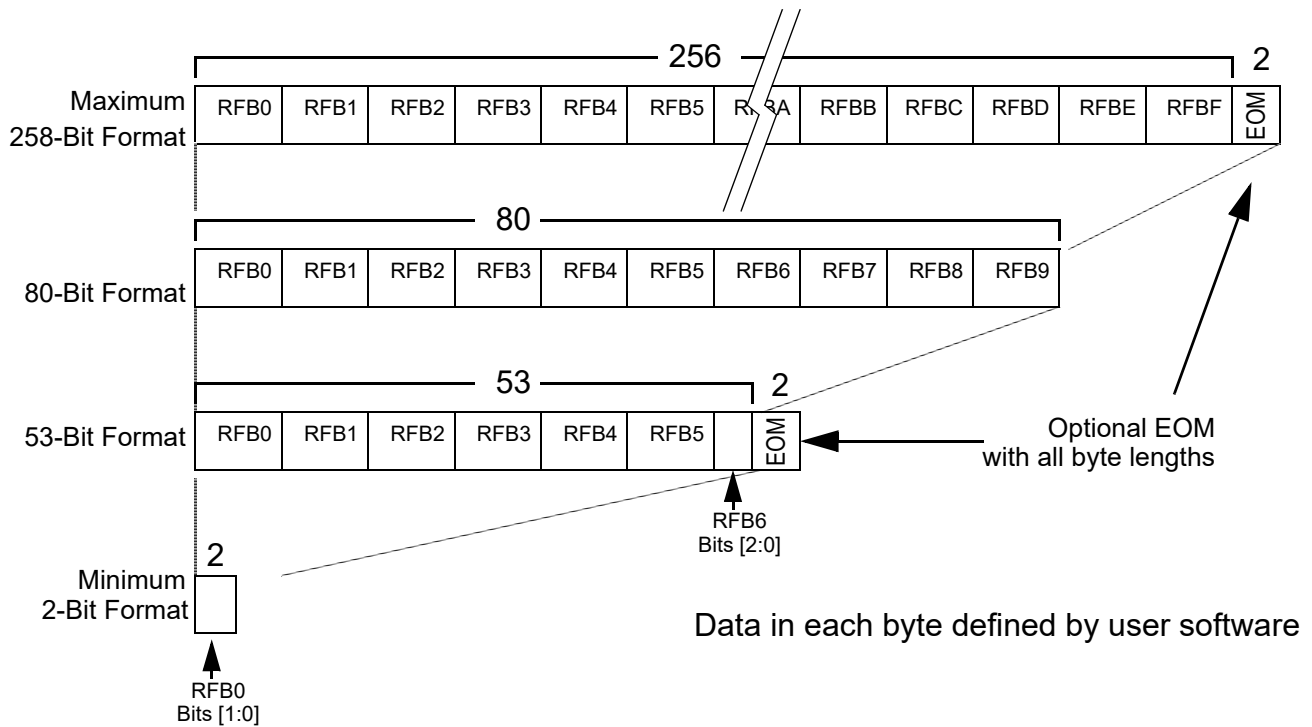

Figure 90. Data Frame Formats

13.2.1 Data Buffer Length

The number of bits sent in a given transmission frame is selected by the FRM[7:0] control bits encoded as a direct binary number plus one. This gives a range of 2 through 256 bits. Data written to data buffer bits above the highest bit number will be ignored. Transmission always begins with the data written in the RFB0 location. When the requested number of bits have been transmitted an interrupt to the MCU can be generated if the RFIE bit is set.

13.2.2 End of Message (EOM)

If the EOM control bit is set, then at the end of the data frame there will be carrier for a period of two bit times at level high for the OOK modulation modes or f_{DATA1} for the FSK modulation modes. Following the EOM period there will be no carrier for either the OOK or FSK modes. If the EOM control bit is clear, no EOM period will be added to the transmission.

13.3 Transmission Randomization

When there are two or more different transmitters, the clock rates of each may drift into synchronism with each other; and there is the possibility of RF data collisions and the loss of data from both transmitters. In order to reduce possible RF data collisions each transmission will contain from 1 to 16 frames of data. Each frame may be spaced at after the initially timed transmission start time and between any two data frames as shown in Figure 91.

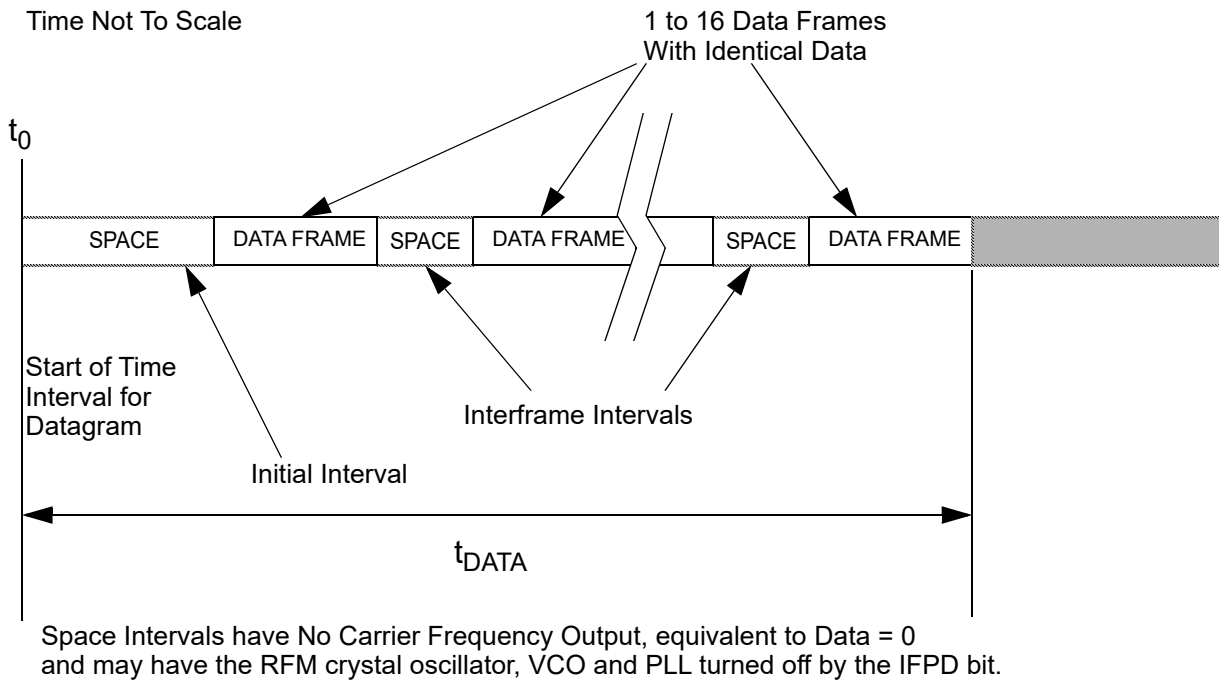
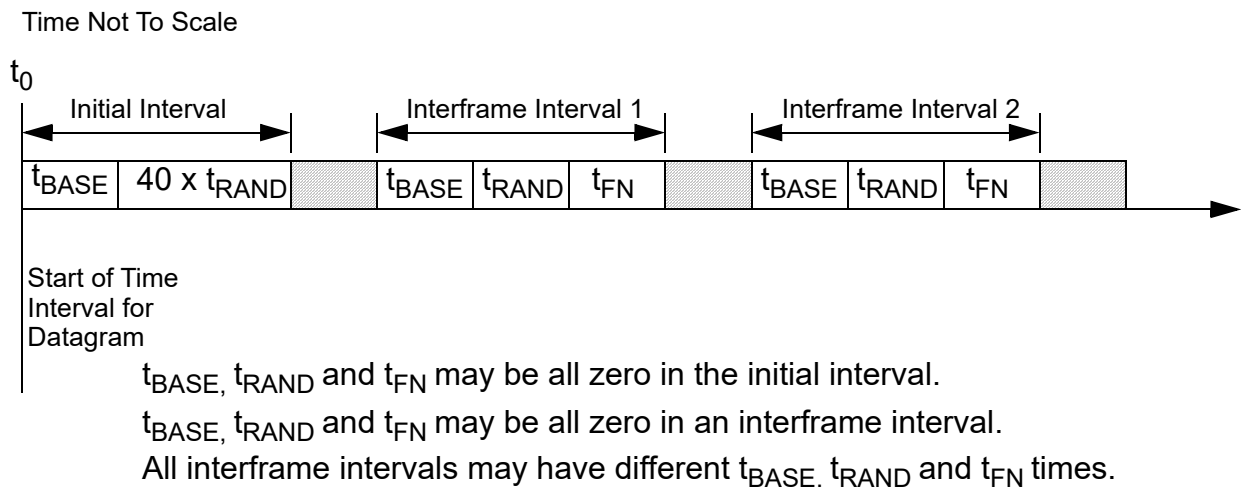

Figure 91. Datagram Overview

The generation of the initial and interframe time intervals can be done with a combination of a programmable counter, a pseudo-random interval generator and a frame counter as shown in Figure 92. The initial time interval can be done by adjusting the start time using the MCU or using this interval timing generator.



Note: If t_{BASE} and t_{FN} are both set to non-zero, and t_{RAND} is set to 0, the system will decrement both t_{BASE} and t_{FN} simultaneously rather than serially, such that the effective Interframe Interval will be equal to the larger of t_{BASE} or t_{FN} settings.

Figure 92. Initial and Interframe Timing

13.3.1 Initial Time Interval

When generating an initial time interval the MCU loads the RFM interval generator variables and then goes into the STOP1 mode. When the initial time interval ends the data in the RFM data buffer is automatically sent and the MCU will wake at the end of the transmission. The initial time interval is made up of two components:

$$t_{\text{INIT}} = t_{\text{BASE}} + 40 \times t_{\text{RAND}} \quad \text{Eqn. 10}$$

where:

- t_{INIT} = Total time interval before first frame is transmitted in ms
- t_{BASE} = Base time in ms; ≤ 5 ms not recommended
- t_{RAND} = Pseudo-random time in ms based on a Galois 7-bit LFSR

The components of this time are described in the following sections.

13.3.2 Interframe Time Intervals

When generating an interframe time interval the MCU loads the RFM interval generator variables and then goes to the STOP1 mode. When the interframe time interval ends the data in the RFM data buffer is automatically sent and the MCU will wake at the end of the transmission. The interframe time interval is made up of three components:

$$t_{\text{IFRM}} = t_{\text{BASE}} + t_{\text{RAND}} + t_{\text{FN}} \quad \text{Eqn. 11}$$

where:

- t_{IFRM} = Total time interval between each transmitted frame in ms
- t_{BASE} = Base time in ms; ≤ 5 ms not recommended
- t_{FN} = Time adder in ms for frame number
- t_{RAND} = Pseudo-random time in ms based on a Galois 7-bit LFSR

The components of this time are described in the following sections.

13.3.3 Base Time Interval

The base time interval, t_{BASE} , is used in the initial time interval and in datagram transmissions with two or more frames. The programmable frame space interval is based on a simple 8-bit, count-down timer as described by the RFBT[7:0] control bits in the RFCR4 register. This time interval is forced to zero when the RFBT[7:0] are all clear.

The range of the base time must be set to 0 or between 5 and 255 ms using a clock generated from the MFO divided by 125.

13.3.4 Pseudo-Random Time Interval

The pseudo-random time interval, t_{RAND} , is used both in the initial and the interframe time intervals if the LFSR[6:0] bits are set to something other than all zeros. When the ISPC bit is set the pseudo-random initial time interval before the first data frame will be 40 times the value of t_{RAND} .

When the LFSR[6:0] bits are used the t_{RAND} time will vary based on a pseudo-random generated binary number using a Galois linear feedback shift register (LFSR) implemented using the primitive polynomial for a 7-stage register as shown in [Figure 93](#).

This LFSR creates a sequence of 127 binary numbers including \$01 through \$3F which are each repeated only once in each sequence of 127 clocks of the shift register. The LFSR is initialized to \$40 during power up of the device. When a random interval is to be determined the contents of the LFSR are sampled as the “random number” for calculating the required interval time. Following the use of the random interval the LFSR is clocked once to advance it to the next pseudo-random number.

The range of the pseudo-random time is 1 to 127 ms using a clock generated from the MFO divided by 125. The current value of the LFSR can be changed and/or read by the LFSR[6:0] bits in the RFCR5 register.

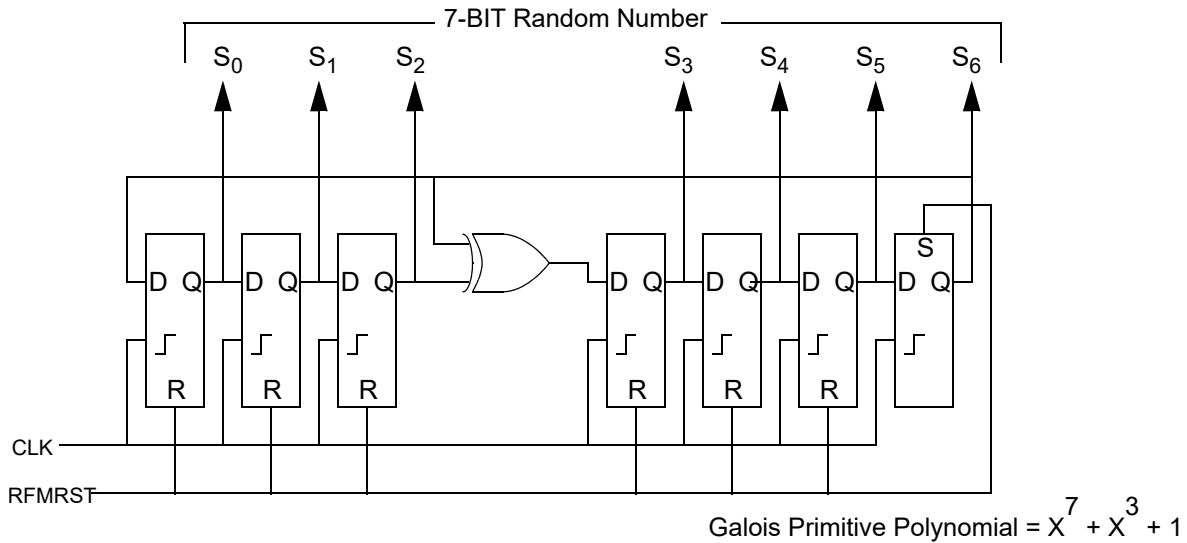

Figure 93. LFSR Implementation

A value of all zeros in the LFSR will remain unchanged with every clock input and cannot be used as a starting “seed.”

The resulting range of times for the initial and interframe pseudo-random time will be as given in [Table 71](#) for both the design center and the variation resulting from the tolerance of the MFO clock.

Table 71. Randomization Interval Times

Time Interval	Randomization Number	Ideal Time Interval (ms)	Time Interval Including MFO Tolerance (ms)	
			Minimum	Maximum
Initial	1	40	37.2	42.8
	127	5080	4347.2	5434.6
Interframe	1	1	0.93	1.07
	127	127	118.1	135.9

13.3.5 Frame Number Time

The frame number time, t_{FN} , is only used between frames and is based on a selectable time from 0 to 63 ms and the number of the frame that was just transmitted as given in [Table 72](#). If the frame number time is not used, the value of the selected time should be set to zero. The maximum number of frames is defined by the FNUM[3:0] control bits.

The range of the frame number time is a multiple of 0 to 63 ms using a clock generated from the MFO divided by 125. The value of this time multiple can be changed by the RFFT[5:0] bits in the RFCR6 register.

Table 72. Frame Number Interval Times

Value of FNUM[3:0]	Number of Frames	Frame Interval Where Time Added	Nominal Frame Number Time Interval Added (ms)	
			Minimum	Maximum
0	1	None	n/a	n/a
1	2	1 - 2	1	63
2	3	2 - 3	2	126
3	4	3 - 4	3	189
4	5	4 - 5	4	252
5	6	5 - 6	5	315
6	7	6 - 7	6	378
7	8	7 - 8	7	441
8	9	8 - 9	8	504

Table 72. Frame Number Interval Times (continued)

Value of FNUM[3:0]	Number of Frames	Frame Interval Where Time Added	Nominal Frame Number Time Interval Added (ms)	
			Minimum	Maximum
9	10	9 - 10	9	567
10	11	10 - 11	10	630
11	12	11 - 12	11	693
12	13	12 - 13	12	756
13	14	13 - 14	13	819
14	15	14 - 15	14	882
15	16	15 - 16	15	945

13.4 RFM in STOP1 Mode

The entire RF transmitter digital section can remain powered up, if enabled by the RFEN bit (see [Section 5.3](#)), when the MCU goes into the STOP1 mode.

13.5 Data Encoding

The CODE[1:0] control bits select either Manchester, Bi-Phase, NRZ or MCU direct data encoding of each data bit being transferred from the RF data buffer to the RF output stage. Further, the polarity of the selected encoding method can be inverted using the POL control bit.

13.5.1 Manchester Encoding

When the CODE[1:0] bits are both clear the data is Manchester encoded format, with data transmitted as a transition in voltage occurring in the middle of the bit time. The polarity of this transition is selected by the POL bit. When the POL bit is cleared, then a logical LOW is defined as an increase in signal in the middle of a bit time and a logical HIGH is defined as a decrease in signal in the middle of a bit time as shown in [Figure 94](#). When the POL bit is set, then a logical LOW is defined as a decrease in signal in the middle of a bit time and a logical HIGH is defined as an increase in signal in the middle of a bit time as shown in [Figure 95](#). Since there is always a transition in the middle of the bit time there must also be a transition at the start of a bit time if consecutive “1” or “0” data are present.

13.5.2 Bi-Phase Encoding

When the CODE[1:0] bits are 0:1 then the data is Bi-Phase encoded format, with data transmitted as the presence or absence of a transition in signal in the middle of the bit time. The polarity of this transition is selected by the POL bit. Unlike Manchester coding there is always a signal transition at the boundaries of each bit time. When the POL bit is cleared, then a logical HIGH is defined as no change in signal in the middle of a bit time and a logical LOW is defined as a change in the signal in the middle of a bit time as shown in [Figure 96](#). When the POL bit is set, then a logical HIGH is defined as a change in signal in the middle of a bit time and a logical LOW is defined as no change in the signal in the middle of a bit time as shown in [Figure 97](#). Since there is always a transition at the ends of the bit time consecutive bits of the same state may have two signal states (high or low) during the middle of the bit time.

13.5.3 NRZ Encoding

When the CODE[1:0] bits are 1:0 then the data is NRZ encoded format, with data transmitted as either a high or low for the complete bit time. The polarity of this state is selected by the POL bit. The Manchester and Bi-Phase encoding can actually be created using NRZ encoding running at twice the desired data rate.

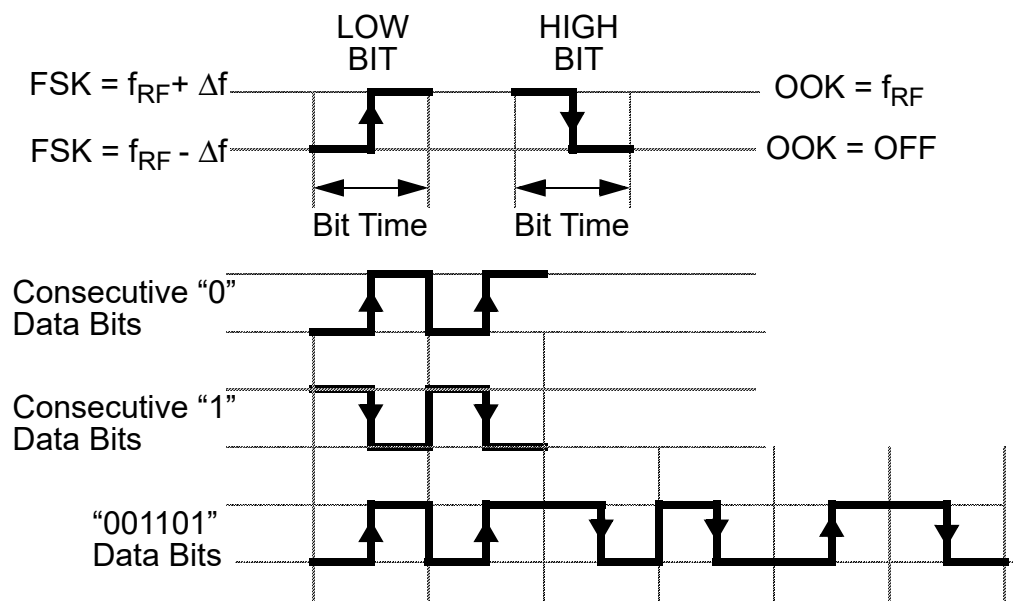

Figure 94. Manchester Data Bit Encoding (POL = 0)

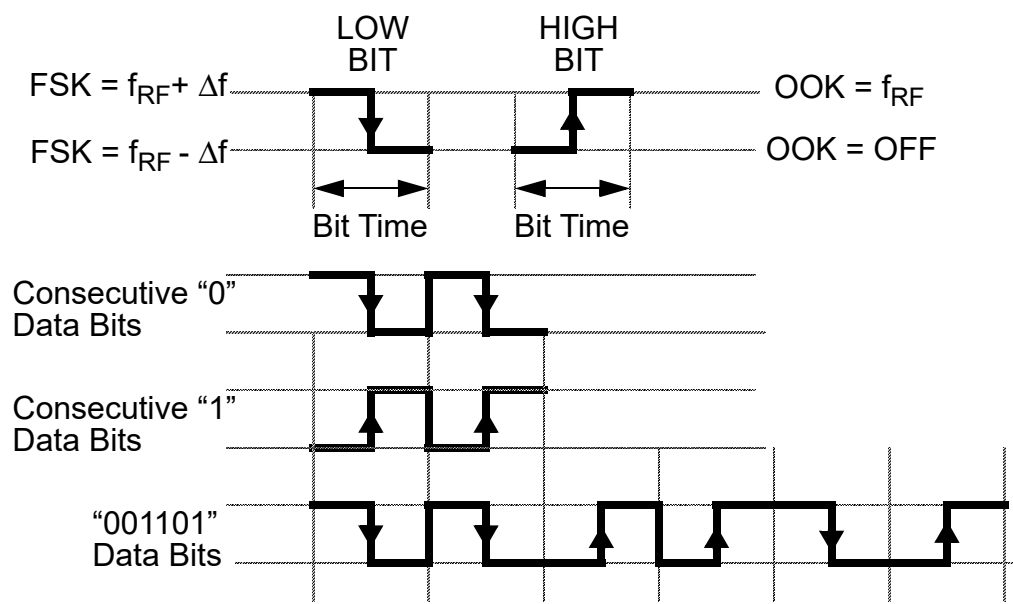

Figure 95. Manchester Data Bit Encoding (POL = 1)

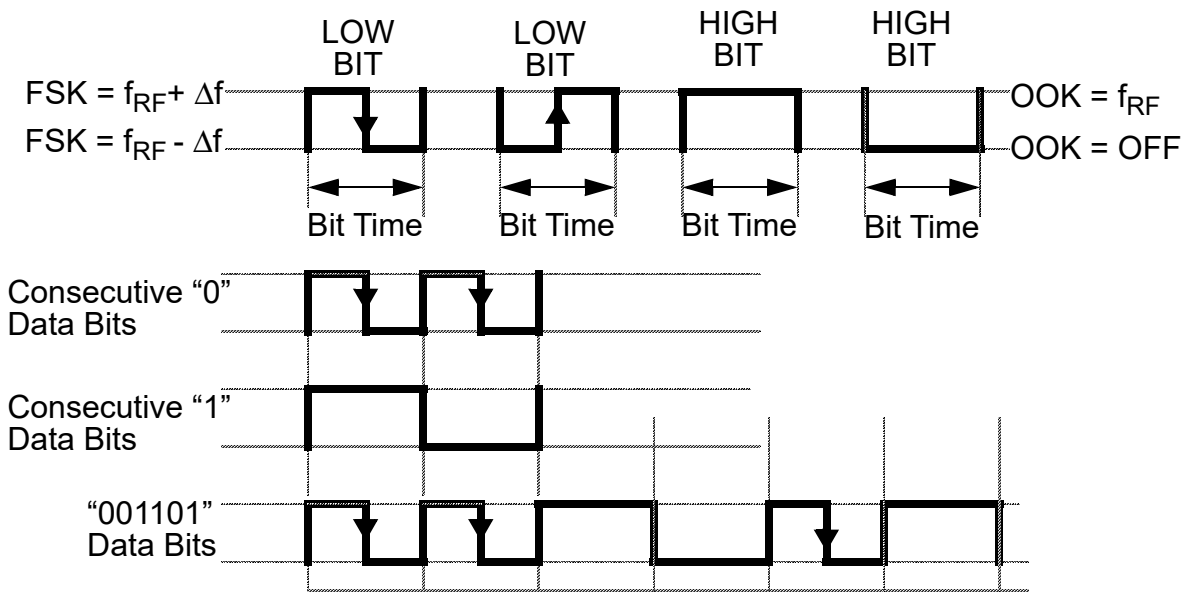

Figure 96. Bi-Phase Data Bit Encoding (POL = 0)

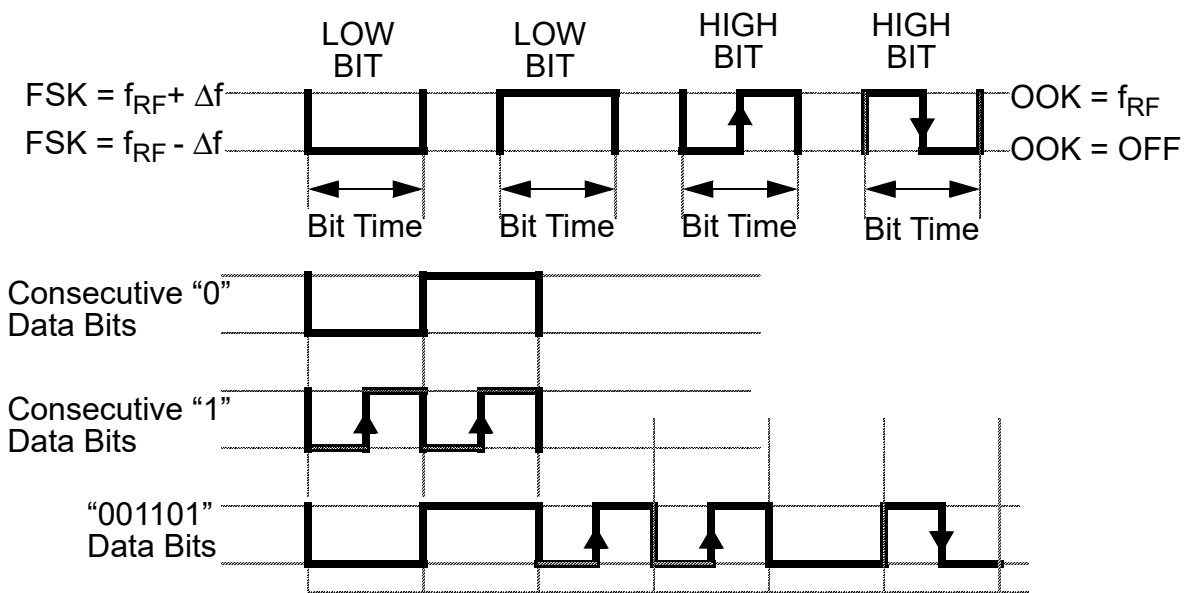

Figure 97. Bi-Phase Data Bit Encoding (POL = 1)

13.6 RF Output Stage

The RF output stage consists of a PLL, control logic and an output RF amplifier. Data is sent to the RF output stage from either the RF data buffer or the DATA bit in the RFCR3 depending on the selected mode of operation as described in [Section 13.1](#).

The RF output stage is enabled by the state of the SEND control bit. The PLL in the RF output stage will signal back via the RCTS status bit when the PLL is locked and ready to transmit.

13.6.1 Modulation Method

The modulation control bit, MOD, described in [Section 13.18](#), sets the modulation of the RF signal will be either amplitude shift keying (OOK) or frequency shift keying (FSK) with several options for the frequency shift.

When operating in the FSK mode the internal, fractional-n PLL divider will be used to create the two carrier frequencies for data zero and data one. This method is more effective and robust than “pulling” the external crystal in order to shift the carrier frequency.

13.6.2 Carrier Frequency

The carrier frequency is established mainly by the external crystal used, but a centering of the fractional-n PLL provides more precise control. If the CF control bit is clear the PLL will be configured for a carrier center frequency of the 315 MHz. If the CF control bit is set the PLL will be configured for a carrier center frequency of the 434 MHz.

13.6.3 RF Power Output

The maximum power output from the RF pin can be adjusted to one of 21 levels using the PWR[4:0] bits.

13.6.4 Transmission Error

Any transmission will be aborted if one of the following occurs:

1. The RCTS signal does not become active within the t_{LOCK} time.
2. The PLL falls out of lock after once being set and the SEND bit is still active.
3. The XCO monitor output falls.

If either of these cases occurs the RF output will be turned off; the SEND control bit will be cleared; and the transmission error status flag, RFEF, will be set. The RFEF bit triggers an interrupt of the MCU if the RFIEN is set. The RFEF bit is cleared by writing a logical one to the RFIK bit.

13.6.5 Supply Voltage Check During RF Transmission

A separate low voltage detector can be enabled during the RF transmission and a status bit checked for low voltage drops due to a weak battery during the higher transmission currents. This RF LVD can be enabled by setting the RFLVDEN bit and the resulting status is reported on the RFVF bit. The RFVF bit can be cleared by writing a logical one to the RFIK bit if the supply voltage has risen above the detect threshold. Further, if the voltage falls far enough for the VCO and PLL to fall out-of-lock, then the RF output will be turned off and the transmission will be terminated.

13.6.6 RF Reset (RFMRST)

The RF state machine, crystal oscillator, PLL and VCO can be reset to the initial off state by the RFMRST signal generated by one of the following methods:

1. Internal RFM power-on reset (RFPOR).
2. Writing a one to the RFMRST bit in the RFCR7.

Any of these reset methods will not alter any data stored in the data buffer.

13.7 RF Interrupt

The RFM will interrupt the MCU when the SEND bit is cleared at the end of a data buffer transmission. This interrupt occurs at the end of a programmed set of frames. If the number of frame count FNUM[3:0] is set to zero, then only one frame is sent and the interrupt occurs at the end of that first frame transmitted. If the number of the frame count is greater than zero, then the interrupt will be generated depending on the state of the IFID bit.

The interrupt will also create a flag bit, RFIF, which can be cleared by writing a logical one to the RFIK bit. The interrupt can be enabled/disabled by the RFIEN bit.

13.8 Datagram Transmission Times

In order to comply with FCC requirements in the US market the periodically transmitted datagram must be less than 1 second in length and be separated by an off time that is at least 10 seconds or at least 30 times longer than the transmission time, whichever is longer. The user software must adhere to this ruling for products intended for the US market.

13.9 RFM Registers

The RFM contains twelve registers to control its functions and 32 registers to provide access to the output data buffer.

13.9.1 RFM Control Register 0 - RFCR0

The RFCR0 register contains eight control bits for setting the output data rate of the RFM as described in [Figure 98](#).

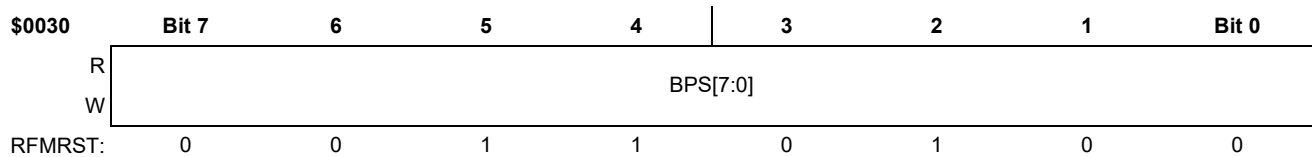

Figure 98. RFM Control Register 0 (RFCR0)

Table 73. RFCR0 Field Descriptions

Field	Description
7-0 BPS[7:0]	<p>Data Rate - The BPS[7:0] control bits select the data rate for the transmitted datagrams as described by the following equation:</p> $f_{\text{DATA}} = \frac{f_{\text{XTAL}}}{52 \times (\text{BPS} + 1)} = \frac{5 \times 10^5}{(\text{BPS} + 1)}$ <p>where:</p> <ul style="list-style-type: none"> f_{DATA} = Data rate in bits/second f_{XTAL} = External crystal frequency in Hz = 26 MHz BPS = Value of data rate code (BPS[7:0]) <p>Examples of the value for common data rates are given in Table 74. The BPS[7:0] control bits are set to \$34 by the RFM RST signal which results in a default data rate of 9600 bits/sec.</p>

Table 74. Data Rate Option Examples

Data Rate		BPS[7:0] Decimal Value	Data Rate		BPS[7:0] Decimal Value
Target	Nominal	$f_{\text{XTAL}} = 26 \text{ MHz}$	Target	Nominal	$f_{\text{XTAL}} = 26 \text{ MHz}$
2000 bps	2000.0	249	4800 bps	4807.7	103
2400 bps	2403.8	207	5000 bps	5000.0	99
4000 bps	4000.0	124	9600 bps	9615.4	51
4500 bps	4504.5	110	19200 bps	19230.8	25

The BPS[7:0] bits are set to \$34 by an RFM RST signal which results in a default data rate of approximately 9600 bps.

13.10 RFM Control Register 1 - RFCR1

The RFCR1 register contains eight control bits for the RFM as described in [Figure 99](#).

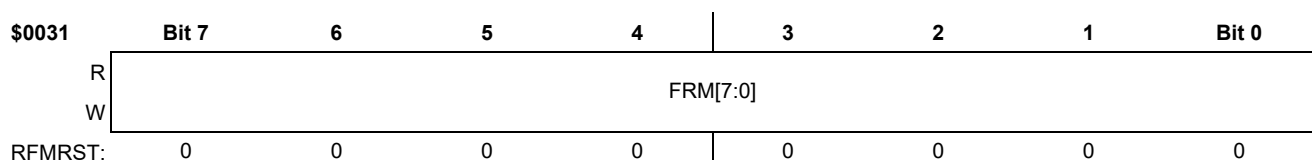

Figure 99. RFM Control Register 1 (RFCR1)

Table 75. RFCR1 Field Descriptions

Field	Description
7-0 FRM[7:0]	Frame Bit Length - The FRM[7:0] control bits select the number of bits in each datagram. The number of bits is determined by the binary value of the FRM[7:0] bits plus one. This makes the range of bits from 2 to 256. A value of \$00 for the FRM[7:0] control bits will result in no frames being sent. The FRM[7:0] control bits are cleared by RFMRST signal.

13.11 RFM Control Register 2 - RFCR2

The RFCR2 register contains eight control bits for the RFM as described in [Figure 100](#).

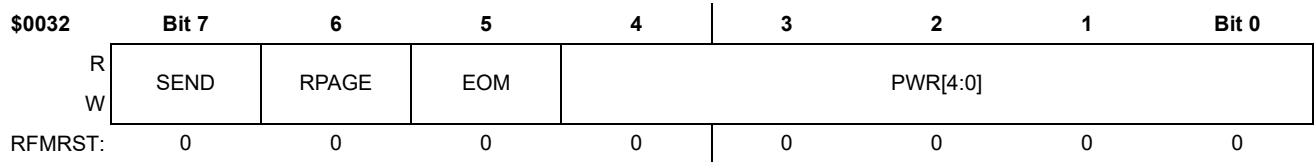

Figure 100. RFM Control Register 2 (RFCR2)

Table 76. RFCR2 Field Descriptions

Field	Description
7 SEND	Transmission Start Control - The SEND control bit starts the transmission of data held in the RFM data buffer according to the bit length specified by the FRM[7:0] bits. The SEND control bit is automatically cleared when the data buffer transmission has ended or by the RFMRST signal. A transmission can be prematurely interrupted by writing a logical zero to the SEND bit. 0 Data transmission ended or transmission not in progress. 1 Start data transmission or transmission in progress.
6 RPAGE	Buffer Page Select — The RPAGE bit will select the lower or upper 16 bytes of the RFM data buffer when writing/reading to the RFD0-RD15 registers. This bit also selects between the lower and upper banks of RFM registers at addresses \$0038 through \$003B. This bit is cleared by a reset of the MCU. 0 Select the lower 16 bytes of the RFM data buffer. 1 Select the upper 16 bytes of the RFM data buffer.
5 EOM	End Of Message - The EOM control bit selects whether there will be two data bit times of data 1 carrier state at the end of each datagram. The EOM control bit is cleared by a RFMRST. 0 EOM bit times not added. 1 EOM bit times added.

Table 76. RFCR2 Field Descriptions (continued)

Field	Description
4:0 PWR[4:0]	<p>RF Amplifier Power Level - The PWR[4:0] control bits select the optimum power output of the RF power amplifier. These power output levels assume optimal matching network to the RF pin. The PWR[4:0] control bits are cleared a RFM reset. The PWR control bits are initially set to 0x00. This setting targets -10 dBm typical power output. The PWR control bits scale the typical output power level from -1.5 to 8 dBm in steps of 0.5 dB and fixes the low power level mode to -10 dBm, The power control range is defined as follows:</p>
	<p>00000 set output power level to -10 dBm (Default Value)</p>
	<p>00001 set output power level to -1.5 dBm</p>
	<p>00010 set output power level to -1.0 dBm</p>
	<p>00011 set output power level to -0.5 dBm</p>
	<p>00100 set output power level to 0.0 dBm</p>
	<p>00101 set output power level to 0.5 dBm</p>
	<p>00110 set output power level to 1.0 dBm</p>
	<p>00111 set output power level to 1.5 dBm</p>
	<p>01000 set output power level to 2.0 dBm</p>
	<p>01001 set output power level to 2.5 dBm</p>
	<p>01010 set output power level to 3.0 dBm</p>
	<p>01011 set output power level to 3.5 dBm</p>
	<p>01100 set output power level to 4.0 dBm</p>
	<p>01101 set output power level to 4.5 dBm</p>
	<p>01110 set output power level to 5.0 dBm</p>
	<p>01111 set output power level to 5.5 dBm</p>
	<p>10000 set output power level to 6.0 dBm</p>
	<p>10001 set output power level to 6.5 dBm</p>
	<p>10010 set output power level to 7.0 dBm</p>
<p>10011 set output power level to 7.5 dBm</p>	
<p>10100 set output power level to 8.0 dBm</p>	
<p>Codes greater than 10100 are reserved for test purposes and should not be used.</p>	

13.11.1 Power Working Domains

The working areas of the RF transmitter are divided into several domains as defined in Figure 101.

P_{TYP}

$T_A = 25\text{ }^\circ\text{C}$ to $60\text{ }^\circ\text{C}$ and $V_{DD} = 2.5\text{ V}$ to 3.6 V

P_{TYP} is where the power step is adjusted to guarantee 5 dBm. The power consumption in this domain is specified at 5 dBm output power step at nominal conditions of $T_A = 25\text{ }^\circ\text{C}$ and $V_{DD} = 3\text{ VDC}$.

P_{MIN}

P_{MIN} is where the power step is adjusted to guarantee a minimum of 3 dBm as shown in Figure 101. The power consumption in this domain is given as the maximum consumption at whatever temperature of supply voltage condition. The P_{MIN} domain is subdivided into two areas according to the lowest supply voltage encountered (1.8 or 2.5 VDC).

P_{MIN_COLD}

$T_A = -40\text{ }^\circ\text{C}$ to $0\text{ }^\circ\text{C}$ and $V_{DD} = 1.8\text{ V}$ to 3.6 V

P_{MIN_HOT}

$T_A = 0\text{ }^\circ\text{C}$ to $25\text{ }^\circ\text{C}$ and $V_{DD} = 2.5\text{ V}$ to 3.6 V

$T_A = 60\text{ }^\circ\text{C}$ to $125\text{ }^\circ\text{C}$ and $V_{DD} = 2.5\text{ V}$ to 3.6 V

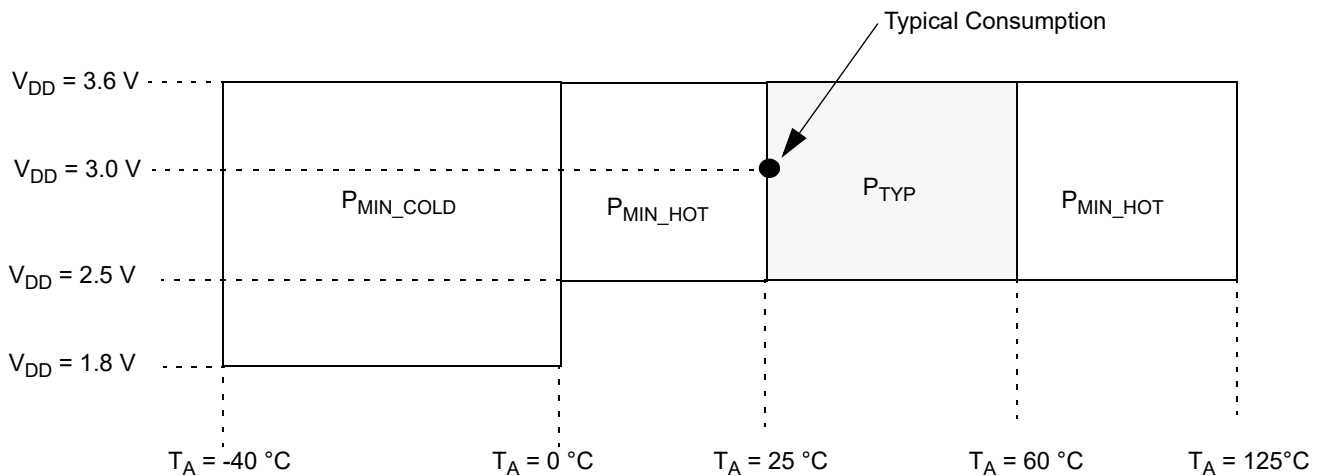

Figure 101. RF Power Domains

13.12 RFM Control Register 3 - RFCR3

The RFCR3 register contains five control bits for the RFM as described in [Figure 102](#) which sets the number of frames in each RF datagram.

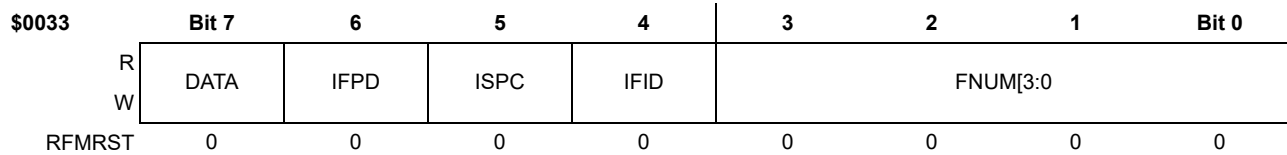

Figure 102. RFM Control Register 3 (RFCR3)

Table 77. RFCR3 Field Descriptions

Field	Description
7 DATA	Data State - The DATA bit determines the output state of the RF power amplifier when the RFM is in the MCU direct control mode (CODE[1:0] = 11) 0 RF output state low. 1 RF output state high.
6 IFPD	Interframe Power Down — The IFPD control bit selects whether the XCO and associated analog blocks are powered down during interframe timing caused by the RFM. The IFPD control bit is cleared by the RFRMST signal. 0 The XCO remains powered up as long as the SEND bit is set. 1 The XCO is powered down during RFM controlled interframe timing events. The restart of these functions will start 1 ms before the end of the timing interval if another frame is to be transmitted.
5 ISPC	Initial Random Space — When the ISPC bit is set the initial time delay before the first frame will be enabled. This bit is cleared by an RFM reset. 0 No initial time interval. 1 Initial time interval enabled.
4 IFID	Interframe Interrupt Delay — The IFID control bit selects whether the RFIF bit is set and the MCU is interrupted at the end of each frame sent or at the end of the last frame in a multiple frame message. The IFID control bit is cleared by the RFRMST signal. 0 The RFIF bit is set and the MCU interrupted if the RFIEN bit is set, after the last frame transmitted. 1 The RFIF bit is set and the MCU interrupted if the RFIEN bit is set, only after the last frame plus an additional interframe message is transmitted.
3-0 FNUM [3:0]	FNUM[3:0] — The FNUM[3:0] bits set the number of frames transmitted in each RF datagram. The frames will be randomly spaced apart as described in Section 13.3 . These bits are cleared by an RFM reset. The number of frame transmitted is the binary number plus one.

13.13 RFM Control Register 4 - RFCR4

The RFCR4 register contains eight control bits to set the initial and interframe timing base timing variable as described in Figure 103. A RFMRST signal clears the RFBT[7:0] bits.

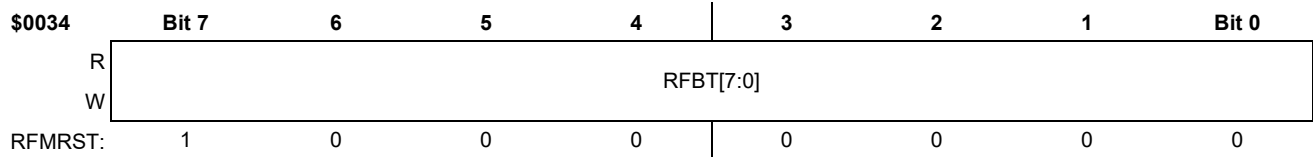

Figure 103. RFCR4 Register - Base Time Variable

Table 78. RFCR4 Field Descriptions

Field	Description
7:0 RFBT [7:0]	Base Timer - The RFBT[7:0] control bits select the interframe timing between multiple frames of transmission. The base time value is equal to a nominal one millisecond for each count of the RFBT[7:0] bits. The RFBT[7:0] control bits are cleared by the RFMRST signal and must be set to either 0 or between 5 and 255.

13.14 RFM Control Register 5 - RFCR5

The RFCR5 register contains eight control bits to set the initial and interframe random timing variable as described in Figure 104. A RFMRST signal clears the LFSR[6:0] bits causing the random time variable to be ignored.

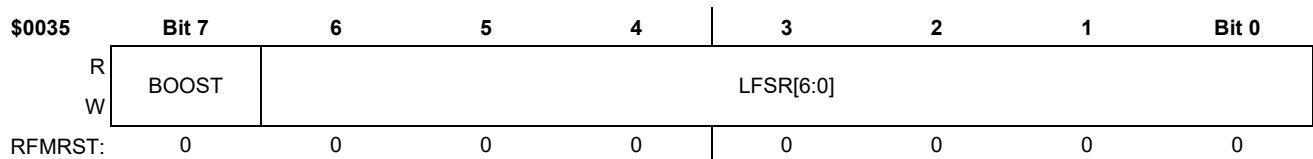

Figure 104. RFCR5 Register - Pseudo-Random Time Variable

Table 79. RFCR5 Field Descriptions

Field	Description
7 BOOST	BOOST - This bit controls the VCO power consumption in order to decrease the phase noise required by the Japanese regulation. The BOOST control bit is cleared by the RFMRST signal. 0 The VCO runs at its lower power consumption level (higher phase noise). 1 The VCO runs at its higher power consumption level (lower phase noise).
6:0 LFSR[6:0]	Pseudo-Random Timer - The LFSR[6:0] bits select the current seed value of the LFSR when enabling pseudo-random timing intervals when any of the LFSR[6:0] bits are set. The value written to this register is loaded into the actual LFSR when the SEND bit is set. The time value is equal to a nominal one millisecond for each count of the resulting LFSR[6:0] bits. A value of \$00 placed in the LFSR causes the LFSR to stay at the \$00 state on each clocking of the LFSR. To cause the LFSR to cycle through its pseudo-random number sequence requires that any value other than \$00 be written to the LFSR[6:0] bits.

NOTE

If RFBT[7:0] and RFFT[5:0] are both set to non-zero, and LFSR[6:0] is set to 0x00, the system will decrement both RFBT and RFFT simultaneously rather than serially, such that the effective Interframe Interval will be equal to the larger of RFBT or RFFT settings.

13.15 RFM Control Register 6 - RFCR6

The RFCR6 register contains eight control bits to set the initial and interframe frame number timing variable as described in [Figure 105](#). A RFMRST signal clears the RFFT[5:0] bits.

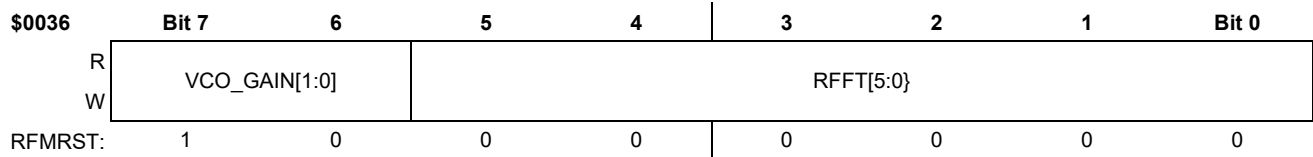

Figure 105. RFCR6 Register - Frame Number Time - RFTS[1:0] = 1:0

Table 80. RFCR6 Field Descriptions

Field	Description
7:6 VCO_GAIN [1:0]	VCO Gain Selection - These bits control the VCO gain. The VCO_GAIN[1] bit is set and the VCO_GAIN[0] bit is cleared by the RFMRST signal. Not normally need to be adjusted by the end user.
5:0 RFFT[5:0]	Frame Number Timer - The RFFT[5:0] control bits select the interframe timing between multiple frames of transmission. The time value is equal to a nominal one millisecond for each count of the RFFT[5:0] bits multiplied by the frame number of the last transmitted frame. The RFFT[5:0] control bits are cleared by the RFMRST signal.

13.16 RFM Control Register 7 - RFCR7

The RFCR7 register contains four control bits and four status bits for the RFM as described in [Figure 106](#).

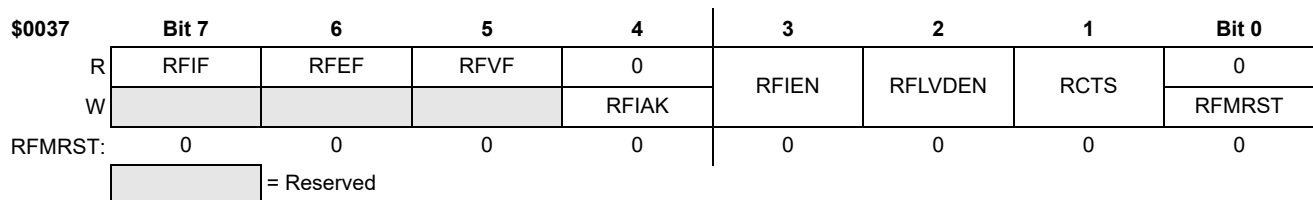

Figure 106. RFM Transmit Control Registers (RFCR7)

Table 81. RFCR7 Field Descriptions

Field	Description
7 RFIF	RF Interrupt Flag — The read-only RFIF status bit indicates if the RF transmission has ended properly when using the data buffer mode and the SEND bit has been cleared. Writes to this bit will be ignored. The RFIF status bit is cleared by writing a logical one to the RFAIK bit or the RFMRST bit. RFMRST signal clears this bit. 0 RF transmission in progress or not in the data buffer mode. 1 RF transmission completed in the data buffer mode.
6 RFEF	RF Transmission Error Flag — The read-only RFEF status bit indicates if there was an error in the current or prior RF transmission as described in Section 13.6.4 . Writes to this bit will be ignored. The RFEF status bit is cleared by writing a logical one to the RFAIK bit or the RFMRST bit. RFMRST signal clears this bit. 0 No RF transmission error occurred. 1 RF transmission error occurred.
5 RFVF	RF LVD Trigger Flag — When the RF LVD is enabled and the supply voltage falls below the threshold, the read-only RFVF flag will be set if the RFLVDEN bit is set. Writes to this bit will be ignored. The RFVF status bit is cleared by writing a logical one to the RFAIK bit or the RFMRST bit. RFMRST signal clears this bit. 0 Voltage is and has been above RF LVD rising threshold or the RF LVD is disabled. 1 Voltage has dropped below the RF LVD falling threshold since last reset of this bit.
4 RFAIK	Acknowledge RF Interrupt Flags — Writing a one to the RFAIK bit clears the RFIF, RFEF and RFVF flag bits. Writing a zero to the RFAIK bit has no effect on the RFIF, RFEF and RFVF flag bits. The RFMRST signal has no effect on this bit. 0 No effect. 1 Clear the RFIF, RFEF, and RFVF bits.

Table 81. RFCR7 Field Descriptions (continued)

Field	Description
3 RFIEN	RF Interrupt Enable — The RFIEN bit enables the RFIF, the RFEF and the RLVF bits to generate an interrupt to the MCU. The RFMRST signal clears this bit. 0 RF interrupts disabled. 1 RF interrupts enabled.
2 RFLVDEN	RF LVD Enable — When the RFLVDEN bit is set, the RF LVD circuit will be enabled, and the RF LVD events are routed to the RF LVD Trigger Flag. This bit is cleared by the RFMRST signal. 0 RF LVD disabled. 1 RF LVD enabled.
1 RCTS	RF Clear To Send Status — When the RCTS bit is set the RF XCO, VCO and PLL have started and locked and the RFM is ready to send data. This bit is cleared by the RFMRST signal. 0 RFM not ready to send. 1 RFM ready to send.
0 RFMRST	RFM Reset — Writing a one to the RFMRST bit will completely reset the RFM and its registers. This bit is not affected by a reset of the MCU. This bit will always read as a zero. 0 No effect. 1 Reset RFM.

13.17 PLL Control Registers A- PLLCR[1:0], RPAGE = 0

The PLLCR[1:0] registers contain 16 control bits for the RFM as described in [Figure 107](#). These bits are only accessible when the RPAGE bit is cleared.

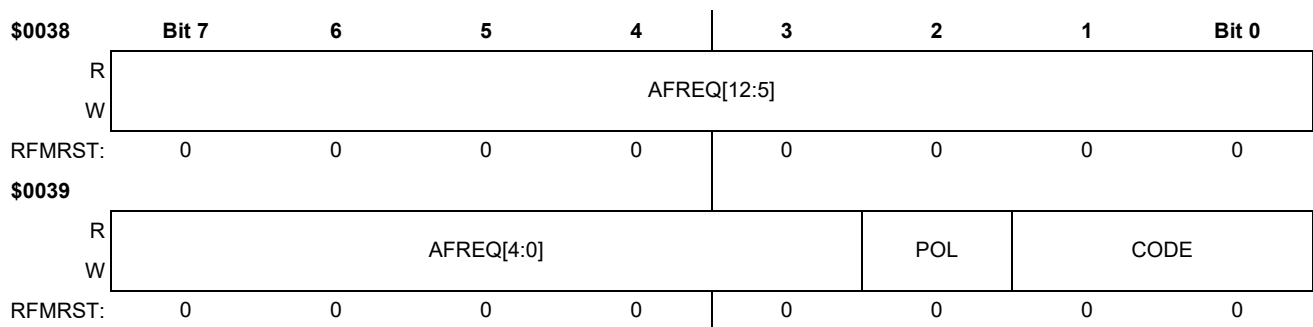

Figure 107. PLL Control Registers A (PLLCR[1:0], RPAGE = 0)

Table 82. PLLCR[1:0] Field Descriptions

Field	Description
PLLCR0 7:0 AFREQ 12:5	PLL Divider Ratio A - The AFREQ[12:0] control bits select the PLL divider ratio for a data zero in the FSK mode of modulation as described by the following equation: where: $f_{\text{DATA0}} = f_{\text{XTAL}} \times \left((12 + 4 \times \text{CF}) + \frac{\text{AFREQ}}{8192} \right)$ f_{DATA0} = RF Carrier frequency for a data zero in MHz f_{XTAL} = External crystal frequency in MHz, 26 MHz CF = State of the CF carrier select bit AFREQ = Decimal value of the AFREQ[12:0] binary weighted bits The AFREQ[12:0] control bits are cleared by the RFMRST signal. 1 LSB of AFREQ[12:0] = 3.17 kHz.
PLLCR1 7:3 AFREQ 4:0	
2 POL	Data Polarity - The POL control bit selects the polarity of the data encoding selected by the CODE[1:0] bits. The POL control bit is cleared by the RFMRST signal. 0 NRZ and MCU direct DATA bit data non-inverted and Manchester encoding polarity as in Figure 95 and Bi-Phase encoding polarity as in Figure 97 . 1 NRZ and MCU direct DATA bit data inverted and Manchester encoding polarity as in Figure 94 and Bi-Phase encoding polarity as in Figure 96 .

Table 82. PLLCR[1:0] Field Descriptions (continued)

Field	Description
1:0 CODE [1:0]	<p>Data Encoding and Source- The CODE[1:0] control bits select the type of data encoding and source of data for the RF output. The CODE[1:0] control bits are cleared by the RFMRST signal.</p> <p>00 Manchester encoded data from the RFM data buffer.</p> <p>01 Bi-Phase encoded data from the RFM data buffer.</p> <p>10 NRZ direct data from the RFM data buffer (can be mixed NRZ and Manchester at 2X the data rate).</p> <p>11 MCU direct mode with RF output driven by the state of the DATA bit.</p>

13.18 PLL Control Registers B- PLLCR[3:2], RPAGE = 0

The PLLCR[3:2] registers contain 16 control bits for the RFM as described in Figure 108. These bits are only accessible when the RPAGE bit is cleared.

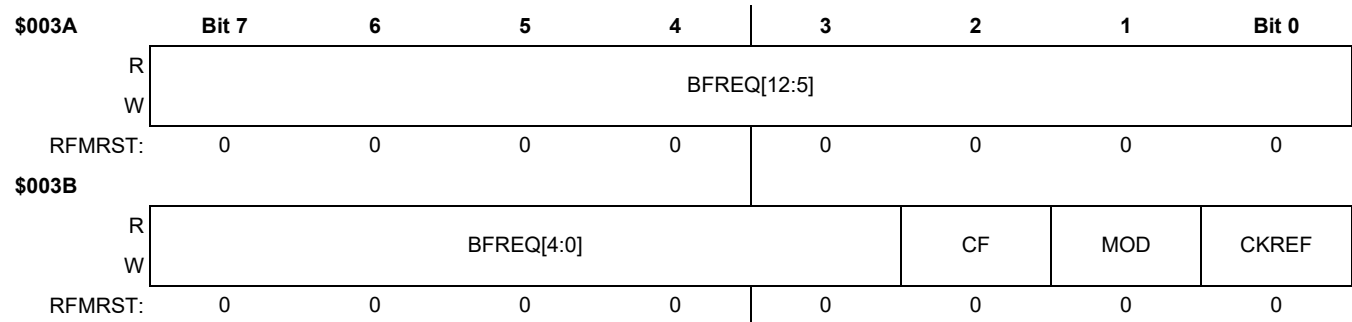

Figure 108. PLL Control Registers B (PLLCR[3:2], RPAGE = 0)

Table 83. PLLCR[3:2] Field Descriptions

Field	Description
PLLCR2 7:0 BFREQ 12:5	<p>PLL Divider Ratio B- The BFREQ[12:0] control bits select the PLL divider ratio for a data one in either the OOK or FSK modes of modulation as described by the following equation:</p> $f_{\text{DATA1}} = f_{\text{XTAL}} \times \left((12 + 4 \times \text{CF}) + \frac{\text{BFREQ}}{8192} \right)$
PLLCR3 7:3 BFREQ 4:0	<p>where:</p> <ul style="list-style-type: none"> f_{CARRIER} = RF Carrier frequency in MHz f_{XTAL} = External crystal frequency in MHz CF = State of the CF carrier select bit BFREQ = Decimal value of the BFREQ[12:0] binary weighted bits <p>The BFREQ[12:0] control bits are cleared by the RFMRST signal. 1 LSB of BFREQ[12:0] = 3.17 kHz.</p>
2 CF	<p>Carrier Frequency - The CF control bit selects the optimal VCO setup and correct divider for the 500 kHz reference clock to the MCU on D_X based on the external crystals required for the desired carrier frequency. The CF control bit is cleared by the RFMRST signal.</p> <p>0 Configured for 315 MHz, 12.1154 PLL divider using a 26.000 MHz external crystal.</p> <p>1 Configured for 434 MHz, 16.6923 PLL divider using a 26.000 MHz external crystal.</p>
1 MOD	<p>RF Modulation Method - The MOD control bit selects the method of modulating the RF. The MOD control bit is cleared by the RFMRST signal.</p> <p>0 Configured for OOK.</p> <p>1 Configured for FSK.</p>
0 CKREF	<p>Generated Clock Reference - Generates the DX signal to the TPM1 module for determining the other clock frequencies:</p> <p>0 D_X signal not generated.</p> <p>1 D_X 500 kHz signal connected to the TPM1 module.</p>

13.19 EPR Register - EPR (RPAGE = 1)

The EPR register contains eight control bits for the RFM as described in Figure 109. The function of the upper 4 bits depends on the state of the VCD_EN bit.

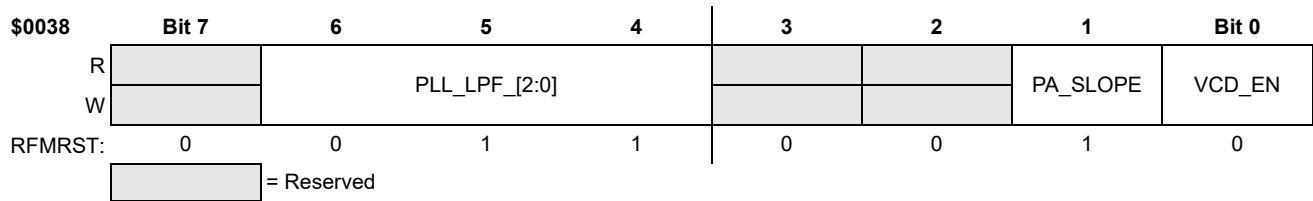

Figure 109. RFM EPR Registers (EPR, RPAGE = 1, VCD_EN = 0)

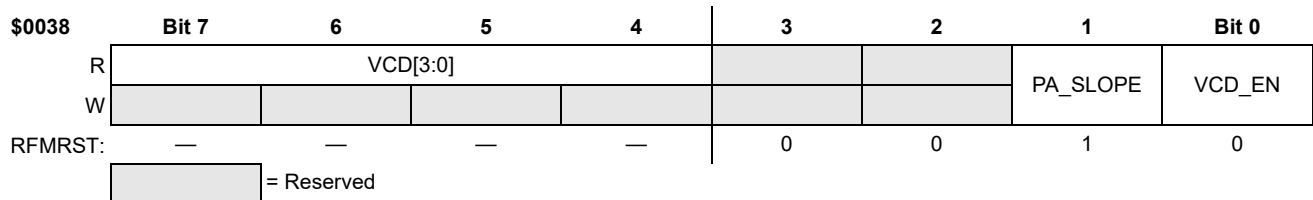

Figure 110. RFM EPR Registers (EPR, RPAGE = 1, VCD_EN = 1)

Table 84. EPR Field Descriptions

Field	Description
7 Reserved	Reserved bit — Not for user access if the VCD_EN bit is clear.
6-4 PLL_LPF_[2:0]	Low Pass Filter Selection - These read/write bits select the PLL low pass filter. A reset sets these bits to \$03. These bits are only accessible if the VCD_EN bit is clear.
7-4 VCD[3:0]	VCO Calibration Count Difference - These read-only bits show the count difference from “ideal” when the VCO calibration machine is finished (see Section 13.21). These bits are only accessible when the VCD_EN bit is set. Writing to these bits when the VCD_EN bit is set has no effect. The reset state is undefined.
3-2 Reserved	Reserved bits — Not for user access.
1 PA_SLOPE	PA Output Slope Selection — This read/write bit controls the output slope of the RFM PA output. This bit is set by the RFMRST signal.
0 VCD_EN	VCD Enable bit — This bit allows access to the VCD[3:0] bits. This bit is cleared by the RFMRST signal. 0 PLL_LPF_[2:0] bits accessed. 1 VCD[3:0] bits accessed.

13.20 RF DATA Registers - RFD[31:0]

The RFD registers contain 256 read/write bits for the RFM to use when outputting data as described in [Section 13.2](#). The 256-bit buffer is divided into two pages of 128 bits as selected by the RPAGE bit in the RFCR2. These as described in [Figure 111](#). These bits are unaffected by any reset.

The data buffer is unloaded to the RF output starting with the least significant bit (RFD0) in the least significant byte (RFB0) up through the most significant bit (RFD255) in the most significant byte (RFB31). This is often referred to as “little-endian” data ordering. The output of this data by the RFM in all 256 bits locations is not dependent on the state of the RPAGE bit.

	Bit 7	6	5	4	3	2	1	Bit 0
\$003C	RFD[7:0] for RPAGE = 0, RFD[135:128] for RPAGE = 1							
\$003D	RFD[15:8] for RPAGE = 0, RFD[143:136] for RPAGE = 1							
\$003E	RFD[23:16] for RPAGE = 0, RFD[151:144] for RPAGE = 1							
\$003F	RFD[31:24] for RPAGE = 0, RFD[159:152] for RPAGE = 1							
\$0040	RFD[39:32] for RPAGE = 0, RFD[167:160] for RPAGE = 1							
\$0041	RFD[47:40] for RPAGE = 0, RFD[175:168] for RPAGE = 1							
\$0042	RFD[55:48] for RPAGE = 0, RFD[183:176] for RPAGE = 1							
\$0043	RFD[63:56] for RPAGE = 0, RFD[191:184] for RPAGE = 1							
\$0044	RFD[71:64] for RPAGE = 0, RFD[199:192] for RPAGE = 1							
\$0045	RFD[79:72] for RPAGE = 0, RFD[207:200] for RPAGE = 1							
\$0046	RFD[87:80] for RPAGE = 0, RFD[215:208] for RPAGE = 1							
\$0047	RFD[95:88] for RPAGE = 0, RFD[223:216] for RPAGE = 1							
\$0048	RFD[103:96] for RPAGE = 0, RFD[231:224] for RPAGE = 1							
\$0049	RFD[111:104] for RPAGE = 0, RFD[239:232] for RPAGE = 1							
\$004A	RFD[119:112] for RPAGE = 0, RFD[247:240] for RPAGE = 1							
\$004B	RFD[127:120] for RPAGE = 0, RFD[255:248] for RPAGE = 1							

Figure 111. RF Data Registers (RFD[31:0])

Table 85. RFD[31:0] Field Descriptions

Field	Description
RFD 15:0 RPAGE = 0	RF Data Registers Lower 128 bits - These are read/write bits that hold the lower 128 bits of possible data to be sent by the RFM. Access to the lower 128 bits occurs when the RPAGE bit is clear. These bits are unaffected by any reset.
RFD [127:0]	
RFD 31:16 RPAGE = 1	RF Data Registers Upper 128 bits - These are read/write bits that hold the upper 128 bits of possible data to be sent by the RFM. Access to the lower 128 bits occurs when the RPAGE bit is clear. These bits are unaffected by any reset.
RFD [255:128]	

13.21 VCO Calibration Machine

The RFM incorporates a VCO calibration machine which works in conjunction with the VCO. The calibration machine selects the optimal VCO sub-band with respect to a predefined reference voltage applied to the VCO.

- Calibration supports maxband VCO sub-bands. maxband corresponds to the band where the VCO frequency is maximum.
- A successive approximation algorithm is used to calculate the optimum sub-band.
- F_c , the Center Frequency $(AFREQ+BFREQ)/2$ is used as the reference frequency for the VCO calibration in FSK mode (MOD = 1).
- BFREQ is used as the reference frequency for the VCO calibration in OOK mode (MOD = 0).
- Calibration occurs every time the VCO is enabled.
- The calibration takes approximately 5 μ s.

The state machine of the calibration is shown in [Figure 112](#).

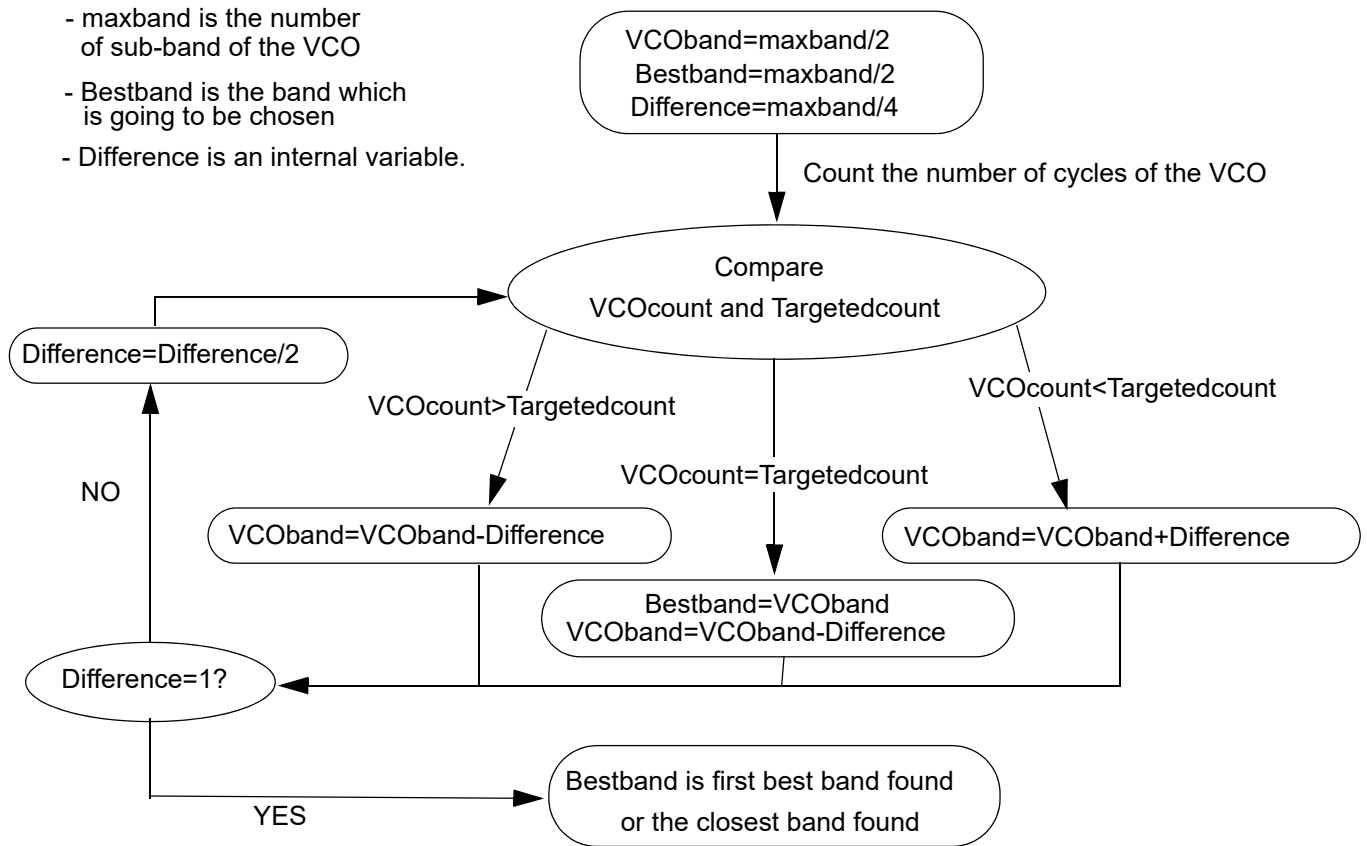

Figure 112. VCO Calibration State Machine

14 Firmware

This section describes the software subroutines contained in the firmware section of the FLASH memory that the user can call for various tasks and to reduce the software development time for the main internal operations.

14.1 Software Jump Table

All subroutines are accessed through a jump table located at the bottom of the firmware FLASH memory as described in [Table 86](#). This allows upgrades in firmware without changing the software code of the user. All subroutines should be accessed with the JSR instruction.

14.2 Function Documentation

The following subsections describe the details of the firmware routines. Further details can be found in the latest version of the FXTH870x6 Embedded Firmware User Guide.

14.2.1 General Rules

1. No output parameter can use the extreme codes (all zero's or all one's).
2. The all zero's output code will always indicate a fault and the status byte will indicate the source of the error.
3. While firmware is processing, CPU resources are unavailable for application.
4. Each measured parameter will return a limit code (\$00, \$FF or \$1FF) if an error occurs in its acquisition, except for the external ADC voltage measurements on the PTA[1:0] pins.
5. External ADC voltage measurements on the PTA[1:0] pins will return a full range code that is ratiometric to the supply voltage.

14.2.1.1 FXTH870x02 Single Z-axis Firmware Routines

The details on the use and execution of each firmware routine is documented in the CodeWarrior project file that is supplied by NXP. Any future updates to these firmware routines will be contained in that file. A summary of the firmware routines available is given in [Table 86](#).

The firmware table is comprised of three-byte entries where the first byte is the operational code for the JMP instruction, and the following two bytes are the absolute address pointing to the location of the firmware function.

Table 86. FXTH870x02 Single Z-axis Firmware Summary and Jump Table

Address	Routine	Description
E000	TPMS_RESET	Master reset of complete device
E003	TPMS_READ_VOLTAGE	10-bit uncompensated bandgap voltage reading
E006	TPMS_COMP_VOLTAGE	8-bit compensation of 10-bit voltage reading
E009	TPMS_READ_TEMPERATURE	10-bit uncompensated temperature reading
E00C	TPMS_COMP_TEMPERATURE	8-bit compensation of 10-bit temperature reading
E00F	TPMS_READ_PRESSURE	10-bit uncompensated pressure reading
E012	TPMS_COMP_PRESSURE	9-bit compensation of 10-bit pressure reading
E015	TPMS_READ_ACCELERATION	10-bit uncompensated acceleration reading
E018	TPMS_COMP_ACCELERATION	9-bit compensation of 10-bit acceleration reading
E01B	TPMS_READ_V0	10-bit uncompensated voltage reading on PTA0 pin
E01E	TPMS_READ_V1	10-bit uncompensated voltage reading on PTA1 pin
E021	TPMS_LFOCAL	LFO clock calibration
E024	TPMS_MFOCAL	MFO clock calibration
E027	TPMS_WAVG	Weighted average (2, 4, 8, 16 or 32)
E02A	TPMS_RF_RESET	Master reset of RFM
E02D	TPMS_RF_READ_DATA	Read RFM data buffer
E030	TPMS_RF_READ_DATA_REVERSE	Read RFM data buffer in reverse bit order
E033	TPMS_RF_WRITE_DATA	Write RFM data buffer
E036	TPMS_RF_WRITE_DATA_REVERSE	Write RFM data buffer in reverse bit order
E039	TPMS_RF_CONFIG_DATA	Configure RFM

Table 86. FXTH870x02 Single Z-axis Firmware Summary and Jump Table (continued)

Address	Routine	Description
E03C	Reserved	Reserved
E03F	TPMS_RF_SET_TX	Initiate RF transmission
E042	TPMS_RF_DYNAMIC_POWER	Adjusts PA for uniform power output
E045	TPMS_MSG_INIT	Initialization of the emulated serial communication
E048	TPMS_MSG_READ	Reading data from emulated serial interface
E04B	TPMS_MSG_WRITE	Writing data on emulated serial interface
E04E	TPMS_CHECKSUM_XOR	Calculates a checksum for given buffer in XOR
E051	TPMS_CRC8	Calculates CRC8 on portion of memory
E054	TPMS_CRC16	Calculates CRC16 on portion of memory
E057	TPMS_SQUARE_ROOT	Calculates square root
E05A	TPMS_READ_ID	Reads device ID stored in FLASH
E05D	TPMS_LF_ENABLE	Enable/Disable LF for Carrier or Data
E060	TPMS_LF_READ_DATA	Reading LF data
E063	TPMS_WIRE_AND_ADC_CHECK	Performs checks of internal bond wires
E066	TPMS_FLASH_WRITE	Write to FLASH
E069	TPMS_FLASH_CHECK	Performs checksum on NXP firmware FLASH
E06C	TPMS_FLASH_ERASE	Erases one page (512 bytes) of FLASH at a time
E06F	TPMS_READ_DYNAMIC_ACCEL	Offsets Z-axis acceleration with one of 15 steps
E072	TPMS_RF_ENABLE	Enable RFM
E075	TPMS_FLASH_PROTECTION	Lock out FLASH
E078	Reserved	Reserved
E07B	TPMS_MULT_SIGN_INT16	Multiple two signed 16-bit numbers together
E07E	TPMS_VREG_CHECK	Verify that external capacitor connected to V _{REG} pin
E081	TPMS_PRECHARGE_VREG	Precharge external capacitor on V _{REG} pin
E084	Reserved	Reserved
E087	TPMS_READ_ACCEL_CONT_START	Enable the TPMS_READ_ACCEL_CONT function.
E08A	TPMS_READ_ACCEL_CONT	Take continuous acceleration readings and store to assigned location.
E08D	TPMS_READ_ACCEL_CONT_STOP	Disable the TPMS_READ_ACCEL_CONT function.

14.2.1.2 FXTH870x11 Dual XZ-axis Firmware Routines

The details on the use and execution of each firmware routine is documented in the CodeWarrior project file that is supplied by NXP. Any future updates to these firmware routines will be contained in that file. A summary of the firmware routines available is given in [Table 87](#).

The firmware table is comprised of three-byte entries where the first byte is the operational code for the JMP instruction, and the following two bytes are the absolute address pointing to the location of the firmware function.

Table 87. FXTH870x11 Dual XZ-axis Firmware Summary and Jump Table

Address	Routine	Description
E000	TPMS_RESET	Master reset of complete device
E003	TPMS_READ_VOLTAGE	10-bit uncompensated bandgap voltage reading
E006	TPMS_COMP_VOLTAGE	8-bit compensation of 10-bit voltage reading
E009	TPMS_READ_TEMPERATURE	10-bit uncompensated temperature reading
E00C	TPMS_COMP_TEMPERATURE	8-bit compensation of 10-bit temperature reading
E00F	TPMS_READ_PRESSURE	10-bit uncompensated pressure reading
E012	TPMS_COMP_PRESSURE	9-bit compensation of 10-bit pressure reading
E015	TPMS_READ_ACCELERATION_X	10-bit uncompensated X-axis accel reading

FXTH870x6

Table 87. FXTH870x11 Dual XZ-axis Firmware Summary and Jump Table (continued)

Address	Routine	Description
E018	TPMS_READ_DYNAMIC_ACCEL_X	10-bit uncompensated X-axis accel reading with dynamic offset adjustment.
E01B	TPMS_COMP_ACCELERATION_X	9-bit compensation of 10-bit X-axis accel reading
E01E	TPMS_READ_ACCELERATION_Z	10-bit uncompensated Z-axis accel reading
E021	TPMS_READ_DYNAMIC_ACCEL_Z	10-bit uncompensated Z-axis accel reading with dynamic offset adjustment.
E024	TPMS_COMP_ACCELERATION_Z	9-bit compensation of 10-bit Z-axis accel reading
E027	TPMS_READ_ACCELERATION_XZ	10-bit uncompensated X-axis and Z-axis accel readings
E02A	TPMS_READ_DYNAMIC_ACCEL_XZ	10-bit uncompensated X-axis and Z-axis accel readings with dynamic offset adjustment.
E02D	TPMS_COMP_ACCELERATION_XZ	9-bit compensation of 10-bit X-axis and Z-axis accel readings
E030	TPMS_READ_V0	10-bit uncompensated voltage reading on PTA0 pin
E033	TPMS_READ_V1	10-bit uncompensated voltage reading on PTA1 pin
E036	TPMS_LFOCAL	LFO clock calibration
E039	TPMS_MFOCAL	MFO clock calibration
E03C	TPMS_RF_ENABLE	Enable and set up RFM
E03F	TPMS_RF_RESET	Master reset of RFM
E042	TPMS_RF_READ_DATA	Read RFM data buffer
E045	TPMS_RF_READ_DATA_REVERSE	Read RFM data buffer in reverse bit order
E048	TPMS_RF_WRITE_DATA	Write RFM data buffer
E04B	TPMS_RF_WRITE_DATA_REVERSE	Write RFM data buffer in reverse bit order
E04E	TPMS_RF_CONFIG_DATA	Configure RFM
E051	Reserved	Reserved
E054	TPMS_RF_SET_TX	Initiate RF transmission
E057	TPMS_RF_DYNAMIC_POWER	Adjusts PA for uniform power output
E05A	TPMS_MSG_INIT	Initialization of the emulated serial communication
E05D	TPMS_MSG_READ	Reading data from emulated serial interface
E060	TPMS_MSG_WRITE	Writing data on emulated serial interface
E063	TPMS_CHECKSUM_XOR	Calculates a checksum for given buffer in XOR
E066	TPMS_CRC8	Calculates CRC8 on portion of memory
E069	TPMS_CRC16	Calculates CRC16 on portion of memory
E06C	TPMS_SQUARE_ROOT	Calculates square root
E06F	TPMS_READ_ID	Reads device ID stored in FLASH
E072	TPMS_LF_ENABLE	Enable/Disable LF for Carrier or Data
E075	TPMS_LF_READ_DATA	Reading LF data
E078	TPMS_WIRE_AND_ADC_CHECK	Performs checks of internal bond wires
E07B	TPMS_FLASH_WRITE	Write to FLASH
E07E	TPMS_FLASH_CHECK	Performs checksum on NXP firmware FLASH
E081	TPMS_FLASH_ERASE	Erases one page (512 bytes) of FLASH at a time
E084	TPMS_FLASH_PROTECTION	Lock out FLASH
E087	Reserved	Reserved
E08A	TPMS_MULT_SIGN_INT16	Multiple two signed 16-bit numbers together
E08D	TPMS_WAVG	Weighted average
E090	Reserved	Reserved

14.2.2 Device Identification

The bytes assigned to identify the device and its options are described below. This data can be read by use of the TPMS_READ_ID routine.

Table 88. Device ID Coding Summary

ID Address	Register Name	Address	Bit 7	6	5	4	3	2	1	Bit 0
00	CODE0	\$E0A0	Reserved - Firmware Revision/Software Information							
01	CODE1	\$FDF2	ES2	ES1	ES0	PRESS	ACC1	ACC0	SPCLA	SPCLP
02	CODE2	\$FDF3	ID7	ID6	ID5	ID4	ID3	ID2	ID1	ID0
03	CODE3	\$FDF4	ID15	ID14	ID13	ID12	ID11	ID10	ID9	ID8
04	CODE4	\$FDF5	ID23	ID22	ID21	ID20	ID19	ID18	ID17	ID16
05	CODE5	\$FDF6	ID31	ID30	ID29	ID28	ID27	ID26	ID25	ID24

ID13:0 — Device ID within assembly lot, 1 through 16383

ID26:14 — Assembly lot ID, 1 through 8191

ID27 — Package ID, 0 for 7 x 7 QFN

ID29:28 — Reserved for future NXP use

ID30 — Final test site ID, 0 or 1

ID31 — Always 1 for NXP

Table 89. Device ID Coding Descriptions

Field	Description
CODE0 7:0 Reserved	Reserved for NXP firmware description. Note: FXTH870922 = Rel1x, all other part numbers = Rel2x
CODE1 7:5 ES	Revision number for the multiple-chip-module silicon. 000 - MCU version 0 111 - MCU version 7
CODE1 4 PRESS-H	Calibrated range for pressure. The range is a combination of this bit and the PRESS-L bit, below. bit 0 = 0, bit 4 = 0 indicates a 100-450 kPa range bit 0 = 0, bit 4 = 1 indicates a 100-900 kPa range
CODE1 3:2 ACC	Type of accelerometer. 00 - None 01 - One accelerometer with X-axis orientation 10 - One accelerometer with Z-axis orientation 11 - Two accelerometers with X- and Z-axis orientations
CODE1 1	Special calibration for accelerometer. 0 = standard -240 to +270 g Z-axis 1 = extended -270 to +400 g Z-axis
CODE1 0 PRESS-L	Calibrated range for pressure. The range is a combination of this bit and the PRESS-H bit, above. bit 0 = 0, bit 4 = 0 indicates a 100-450 kPa range bit 0 = 0, bit 4 = 1 indicates a 100-900 kPa range
CODE2 to CODE5 ID31:0	Refer to Table 88

14.2.3 Definition of Signal Ranges

Each measured parameter (pressure, voltage, temperature, acceleration) results from an ADC10 conversion of an analog signal. This ADC10 result may then be passed by the firmware to the application software as either the raw ADC10 result or further compensated and scaled for an output between one and the maximum digital value minus one. The minimum digital value of zero and the maximum digital value are reserved as error codes.

The signal ranges and their significant data points are shown in Figure 113. In this definition the signal source would normally output a signal between S_{INLO} and S_{INHI} . Due to process, temperature and voltage variations this signal may increase its range to S_{INMIN} to S_{INMAX} . In all cases the signal will be between the supply rails, so that the ADC10 will convert it to a range of digital numbers between 0 and 1023. These digital numbers will have corresponding D_{INMIN} , D_{INLO} , D_{INHI} , D_{INMAX} values. The ADC10 digital value is taken by the firmware and compensated and scaled to give the required output code range.



Figure 113. Measurement Signal Range Definitions

Digital input values below D_{INMIN} and above D_{INMAX} are immediately flagged as being out of range and generate error bits and the output is forced to the 0 value.

Digital values below D_{INLO} (but above D_{INMIN}) or above D_{INHI} (but not D_{INMAX}) will most likely cause an output that would be less than 1 or greater than 510, respectively. These cases are considered underflow or overflow, respectively. Underflow results will be forced to a value of 1. Overflow results will be forced to a value of 510.

Digital values between D_{INLO} and D_{INHI} will normally produce an output between 1 to 510 (for a 9-bit result). In some isolated cases due to compensation calculations and rounding the result may be less than 1 or greater than 510, in which case the underflow and overflow rule mentioned above is used.

14.3 Memory Resource Usage

The firmware uses the top 8192 bytes of the FLASH memory map.

The firmware uses no specific bytes of the RAM but will cause additional stacking of temporary values.

The firmware uses two bytes (\$008E and \$008F) of the Parameter Registers for global flags for all routines.

Software Stack

The RESET firmware function sets the SP register to the last address in the RAM. The user can change the default stack location to meet its own application needs.

15 Development Support

15.1 Introduction

This chapter describes the single-wire BACKGROUND DEBUG mode (BDM), which uses the on-chip BACKGROUND DEBUG controller (BDC) module.

15.1.1 Features

Features of the BDC module include:

- Single pin for mode selection and background communications
- BDC registers are not located in the memory map
- SYNC command to determine target communications rate
- Non-intrusive commands for memory access
- ACTIVE BACKGROUND mode commands for CPU register access
- GO and TRACE1 commands
- BACKGROUND command can wake CPU from STOP or WAIT modes
- One hardware address breakpoint built into BDC
- Oscillator runs in STOP mode, if BDC enabled
- COP watchdog disabled while in ACTIVE BACKGROUND mode

15.2 Background Debug Controller (BDC)

All MCUs in the HCS08 Family contain a single-wire BACKGROUND DEBUG interface that supports in-circuit programming of on-chip nonvolatile memory and sophisticated non-intrusive debug capabilities. Unlike debug interfaces on earlier 8-bit MCUs, this system does not interfere with normal application resources. It does not use any user memory or locations in the memory map and does not share any on-chip peripherals.

BDC commands are divided into two groups:

- ACTIVE BACKGROUND mode commands require that the target MCU is in ACTIVE BACKGROUND mode (the user program is not running). ACTIVE BACKGROUND mode commands allow the CPU registers to be read or written, and allow the user to trace one user instruction at a time, or GO to the user program from ACTIVE BACKGROUND mode.
- Non-intrusive commands can be executed at any time even while the user's program is running. Non-intrusive commands allow a user to read or write MCU memory locations or access status and control registers within the BACKGROUND DEBUG controller.

Typically, a relatively simple interface pod is used to translate commands from a host computer into commands for the custom serial interface to the single-wire BACKGROUND DEBUG system. Depending on the development tool vendor, this interface pod may use a standard RS-232 serial port, a parallel printer port, or some other type of communications such as a universal serial bus (USB) to communicate between the host PC and the pod. The pod typically connects to the target system with ground, the BKGD/PTA4 pin, $\overline{\text{RESET}}$, and sometimes V_{DD} . An open-drain connection to reset allows the host to force a target system reset, which is useful to regain control of a lost target system or to control startup of a target system before the on-chip nonvolatile memory has been programmed. Sometimes V_{DD} can be used to allow the pod to use power from the target system to avoid the need for a separate power supply. However, if the pod is powered separately, it can be connected to a running target system without forcing a target system reset or otherwise disturbing the running application program.

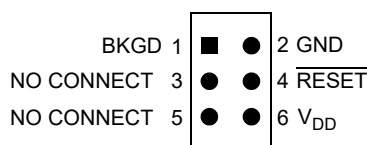

Figure 114. BDM Tool Connector

15.2.1 BKGD/PTA4 Pin Description

BKGD/PTA4 is the single-wire BACKGROUND DEBUG interface pin. The primary function of this pin is for bidirectional serial communication of ACTIVE BACKGROUND mode commands and data. During reset, this pin is used to select between starting in ACTIVE BACKGROUND mode or starting the user's application program. This pin is also used to request a timed sync response pulse to allow a host development tool to determine the correct clock frequency for BACKGROUND DEBUG serial communications.

BDC serial communications use a custom serial protocol first introduced on the M68HC12 Family of microcontrollers. This protocol assumes the host knows the communication clock rate that is determined by the target BDC clock rate. All communication is initiated and controlled by the host that drives a high-to-low edge to signal the beginning of each bit time. Commands and data are sent most significant bit first (MSB first). For a detailed description of the communications protocol, refer to [Section 15.2.2](#).

If a host is attempting to communicate with a target MCU that has an unknown BDC clock rate, a SYNC command may be sent to the target MCU to request a timed sync response signal from which the host can determine the correct communication speed.

BKGD/PTA4 is a pseudo-open-drain pin and there is an on-chip pullup so no external pullup resistor is required. Unlike typical open-drain pins, the external RC time constant on this pin, which is influenced by external capacitance, plays almost no role in signal rise time. The custom protocol provides for brief, actively driven speedup pulses to force rapid rise times on this pin without risking harmful drive level conflicts. Refer to [Section 15.2.2](#), for more detail.

When no debugger pod is connected to the 6-pin BDM interface connector, the internal pullup on BKGD/PTA4 chooses normal operating mode. When a debug pod is connected to BKGD/PTA4 it is possible to force the MCU into ACTIVE BACKGROUND mode after reset. The specific conditions for forcing ACTIVE BACKGROUND depend upon the HCS08 derivative (refer to the introduction to this Development Support section). It is not necessary to reset the target MCU to communicate with it through the BACKGROUND DEBUG interface.

15.2.2 Communication Details

The BDC serial interface requires the external controller to generate a falling edge on the BKGD/PTA4 pin to indicate the start of each bit time. The external controller provides this falling edge whether data is transmitted or received.

BKGD/PTA4 is a pseudo-open-drain pin that can be driven either by an external controller or by the MCU. Data is transferred MSB first at 16 BDC clock cycles per bit (nominal speed). The interface times out if 512 BDC clock cycles occur between falling edges from the host. Any BDC command that was in progress when this timeout occurs is aborted without affecting the memory or operating mode of the target MCU system.

The custom serial protocol requires the debug pod to know the target BDC communication clock speed.

The clock switch (CLKSW) control bit in the BDC status and control register allows the user to select the BDC clock source. The BDC clock source can either be the bus or the alternate BDC clock source.

The BKGD/PTA4 pin can receive a high or low level or transmit a high or low level. The following diagrams show timing for each of these cases. Interface timing is synchronous to clocks in the target BDC, but asynchronous to the external host. The internal BDC clock signal is shown for reference in counting cycles.

[Figure 115](#) shows an external host transmitting a logic 1 or 0 to the BKGD/PTA4 pin of a target HCS08 MCU. The host is asynchronous to the target so there is a 0-to-1 cycle delay from the host-generated falling edge to where the target perceives the beginning of the bit time. Ten target BDC clock cycles later, the target senses the bit level on the BKGD/PTA4 pin. Typically, the host actively drives the pseudo-open-drain BKGD/PTA4 pin during host-to-target transmissions to speed up rising edges. Because the target does not drive the BKGD/PTA4 pin during the host-to-target transmission period, there is no need to treat the line as an open-drain signal during this period.

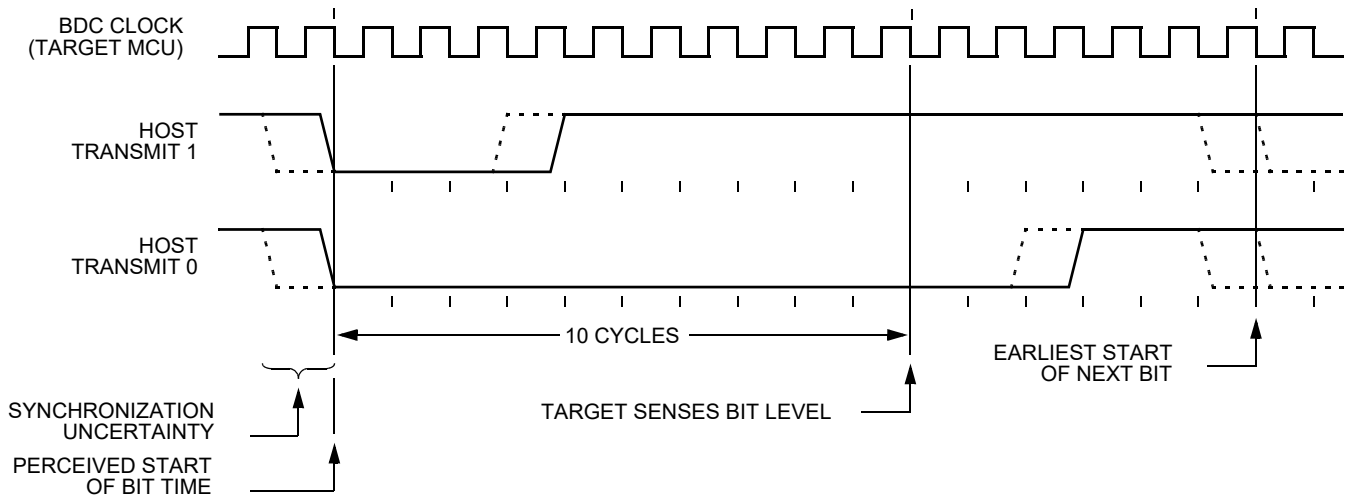

Figure 115. BDC Host-to-Target Serial Bit Timing

Figure 116 shows the host receiving a logic 1 from the target HCS08 MCU. Because the host is asynchronous to the target MCU, there is a 0-to-1 cycle delay from the host-generated falling edge on BKGD/PTA4 to the perceived start of the bit time in the target MCU. The host holds the BKGD/PTA4 pin low long enough for the target to recognize it (at least two target BDC cycles). The host must release the low drive before the target MCU drives a brief active-high speedup pulse seven cycles after the perceived start of the bit time. The host should sample the bit level about 10 cycles after it started the bit time.

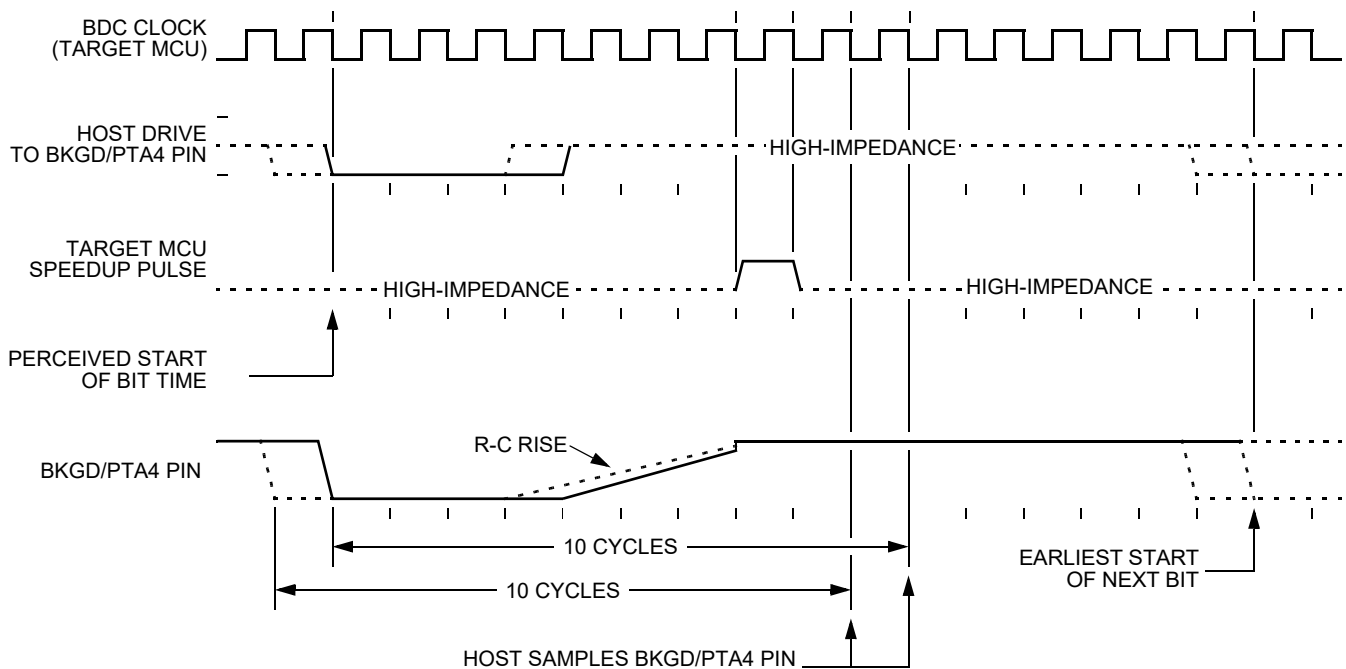

Figure 116. BDC Target-to-Host Serial Bit Timing (Logic 1)

Figure 117 shows the host receiving a logic 0 from the target HCS08 MCU. Because the host is asynchronous to the target MCU, there is a 0-to-1 cycle delay from the host-generated falling edge on BKGD/PTA4 to the start of the bit time as perceived by the target MCU. The host initiates the bit time but the target HCS08 finishes it. Because the target wants the host to receive a logic 0, it drives the BKGD/PTA4 pin low for 13 BDC clock cycles, then briefly drives it high to speed up the rising edge. The host samples the bit level about 10 cycles after starting the bit time.

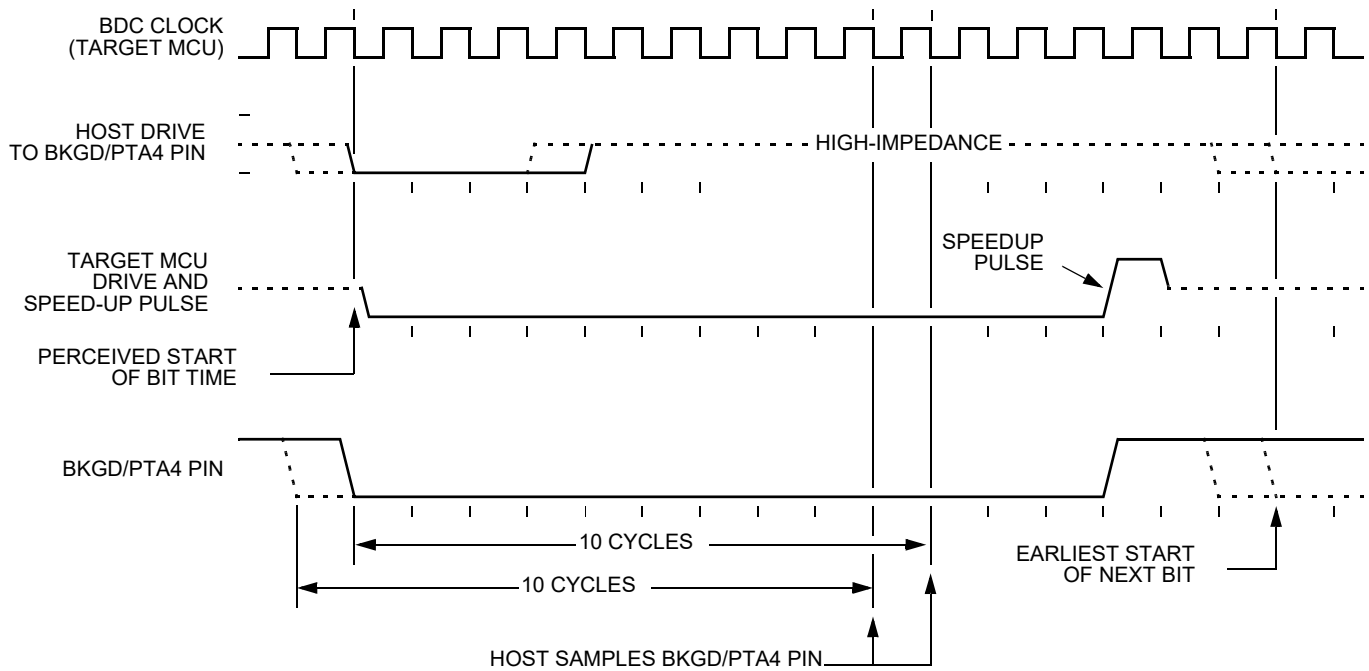

Figure 117. BDM Target-to-Host Serial Bit Timing (Logic 0)

15.2.3 BDC Commands

BDC commands are sent serially from a host computer to the BKGD/PTA4 pin of the target HCS08 MCU. All commands and data are sent MSB-first using a custom BDC communications protocol. ACTIVE BACKGROUND mode commands require that the target MCU is currently in the ACTIVE BACKGROUND mode while non-intrusive commands may be issued at any time whether the target MCU is in ACTIVE BACKGROUND mode or running a user application program. Table 90 shows all HCS08 BDC commands, a shorthand description of their coding structure, and the meaning of each command.

Coding Structure Nomenclature

This nomenclature is used in Table 90 to describe the coding structure of the BDC commands. Commands begin with an 8-bit hexadecimal command code in the host-to-target direction (most significant bit first)

/	=	separates parts of the command
d	=	delay 16 target BDC clock cycles
AAAA	=	a 16-bit address in the host-to-target direction
RD	=	8 bits of read data in the target-to-host direction
WD	=	8 bits of write data in the host-to-target direction
RD16	=	16 bits of read data in the target-to-host direction
WD16	=	16 bits of write data in the host-to-target direction
SS	=	the contents of BDCSCR in the target-to-host direction (STATUS)
CC	=	8 bits of write data for BDCSCR in the host-to-target direction (CONTROL)
RBKP	=	16 bits of read data in the target-to-host direction (from BDCBKPT breakpoint register)
WBKP	=	16 bits of write data in the host-to-target direction (for BDCBKPT breakpoint register)

Table 90. BDC Command Summary

Command Mnemonic	Active BDM/ Non-intrusive	Coding Structure	Description
SYNC	Non-intrusive	n/a ⁽¹⁾	Request a timed reference pulse to determine target BDC communication speed
ACK_ENABLE	Non-intrusive	D5/d	Enable acknowledge protocol. Refer to NXP document order no. HCS08RMv1/D.
ACK_DISABLE	Non-intrusive	D6/d	Disable acknowledge protocol. Refer to NXP document order no. HCS08RMv1/D.
BACKGROUND	Non-intrusive	90/d	Enter ACTIVE BACKGROUND mode if enabled (ignore if ENBDM bit equals 0)
READ_STATUS	Non-intrusive	E4/SS	Read BDC status from BDCSCR
WRITE_CONTROL	Non-intrusive	C4/CC	Write BDC controls in BDCSCR
READ_BYTE	Non-intrusive	E0/AAAA/d/RD	Read a byte from target memory
READ_BYTE_WS	Non-intrusive	E1/AAAA/d/SS/RD	Read a byte and report status
READ_LAST	Non-intrusive	E8/SS/RD	Re-read byte from address just read and report status
WRITE_BYTE	Non-intrusive	C0/AAAA/WD/d	Write a byte to target memory
WRITE_BYTE_WS	Non-intrusive	C1/AAAA/WD/d/SS	Write a byte and report status
READ_BKPT	Non-intrusive	E2/RBKP	Read BDCBKPT breakpoint register
WRITE_BKPT	Non-intrusive	C2/WBKP	Write BDCBKPT breakpoint register
GO	Active BDM	08/d	Go to execute the user application program starting at the address currently in the PC
TRACE1	Active BDM	10/d	Trace 1 user instruction at the address in the PC, then return to ACTIVE BACKGROUND mode
TAGGO	Active BDM	18/d	Same as GO but enable external tagging (HCS08 devices have no external tagging pin)
READ_A	Active BDM	68/d/RD	Read accumulator (A)
READ_CCR	Active BDM	69/d/RD	Read condition code register (CCR)
READ_PC	Active BDM	6B/d/RD16	Read program counter (PC)
READ_HX	Active BDM	6C/d/RD16	Read H and X register pair (H:X)
READ_SP	Active BDM	6F/d/RD16	Read stack pointer (SP)
READ_NEXT	Active BDM	70/d/RD	Increment H:X by one then read memory byte located at H:X
READ_NEXT_WS	Active BDM	71/d/SS/RD	Increment H:X by one then read memory byte located at H:X. Report status and data.
WRITE_A	Active BDM	48/WD/d	Write accumulator (A)
WRITE_CCR	Active BDM	49/WD/d	Write condition code register (CCR)
WRITE_PC	Active BDM	4B/WD16/d	Write program counter (PC)
WRITE_HX	Active BDM	4C/WD16/d	Write H and X register pair (H:X)
WRITE_SP	Active BDM	4F/WD16/d	Write stack pointer (SP)
WRITE_NEXT	Active BDM	50/WD/d	Increment H:X by one, then write memory byte located at H:X
WRITE_NEXT_WS	Active BDM	51/WD/d/SS	Increment H:X by one, then write memory byte located at H:X. Also report status.

1. The SYNC command is a special operation that does not have a command code.

The SYNC command is unlike other BDC commands because the host does not necessarily know the correct communications speed to use for BDC communications until after it has analyzed the response to the SYNC command.

To issue a SYNC command, the host:

- Drives the BKGD/PTA4 pin low for at least 128 cycles of the slowest possible BDC clock (The slowest clock is normally the reference oscillator/64 or the self-clocked rate/64.)

- Drives BKGD/PTA4 high for a brief speedup pulse to get a fast rise time (This speedup pulse is typically one cycle of the fastest clock in the system.)
- Removes all drive to the BKGD/PTA4 pin so it reverts to high impedance
- Monitors the BKGD/PTA4 pin for the sync response pulse

The target, upon detecting the SYNC request from the host (which is a much longer low time than would ever occur during normal BDC communications):

- Waits for BKGD/PTA4 to return to a logic high
- Delays 16 cycles to allow the host to STOP driving the high speedup pulse
- Drives BKGD/PTA4 low for 128 BDC clock cycles
- Drives a 1-cycle high speedup pulse to force a fast rise time on BKGD/PTA4
- Removes all drive to the BKGD/PTA4 pin so it reverts to high impedance

The host measures the low time of this 128-cycle sync response pulse and determines the correct speed for subsequent BDC communications. Typically, the host can determine the correct communication speed within a few percent of the actual target speed and the communication protocol can easily tolerate speed errors of several percent.

15.2.4 BDC Hardware Breakpoint

The BDC includes one relatively simple hardware breakpoint that compares the CPU address bus to a 16-bit match value in the BDCBKPT register. This breakpoint can generate a forced breakpoint or a tagged breakpoint. A forced breakpoint causes the CPU to enter ACTIVE BACKGROUND mode at the first instruction boundary following any access to the breakpoint address. The tagged breakpoint causes the instruction opcode at the breakpoint address to be tagged so that the CPU will enter ACTIVE BACKGROUND mode rather than executing that instruction if and when it reaches the end of the instruction queue. This implies that tagged breakpoints can only be placed at the address of an instruction opcode while forced breakpoints can be set at any address.

The breakpoint enable (BKPTEN) control bit in the BDC status and control register (BDCSCR) is used to enable the breakpoint logic (BKPTEN = 1). When BKPTEN = 0, its default value after reset, the breakpoint logic is disabled and no BDC breakpoints are requested regardless of the values in other BDC breakpoint registers and control bits. The force/tag select (FTS) control bit in BDCSCR is used to select forced (FTS = 1) or tagged (FTS = 0) type breakpoints.

15.3 Register Definition

This section contains the descriptions of the BDC registers and control bits.

This section refers to registers and control bits only by their names. A NXP provided equate or header file is used to translate these names into the appropriate absolute addresses.

15.3.1 BDC Registers and Control Bits

The BDC has two registers:

- The BDC status and control register (BDCSCR) is an 8-bit register containing control and status bits for the BACKGROUND DEBUG controller.
- The BDC breakpoint match register (BDCBKPT) holds a 16-bit breakpoint match address.

These registers are accessed with dedicated serial BDC commands and are not located in the memory space of the target MCU (so they do not have addresses and cannot be accessed by user programs).

Some of the bits in the BDCSCR have write limitations; otherwise, these registers may be read or written at any time. For example, the ENBDM control bit may not be written while the MCU is in ACTIVE BACKGROUND mode. (This prevents the ambiguous condition of the control bit forbidding ACTIVE BACKGROUND mode while the MCU is already in ACTIVE BACKGROUND mode.) Also, the four status bits (BDMACT, WS, WSF, and DVF) are read-only status indicators and can never be written by the WRITE_CONTROL serial BDC command. The clock switch (CLKSW) control bit may be read or written at any time.

15.3.2 BDC Status and Control Register (BDCSCR)

This register can be read or written by serial BDC commands (READ_STATUS and WRITE_CONTROL) but is not accessible to user programs because it is not located in the normal memory map of the MCU.

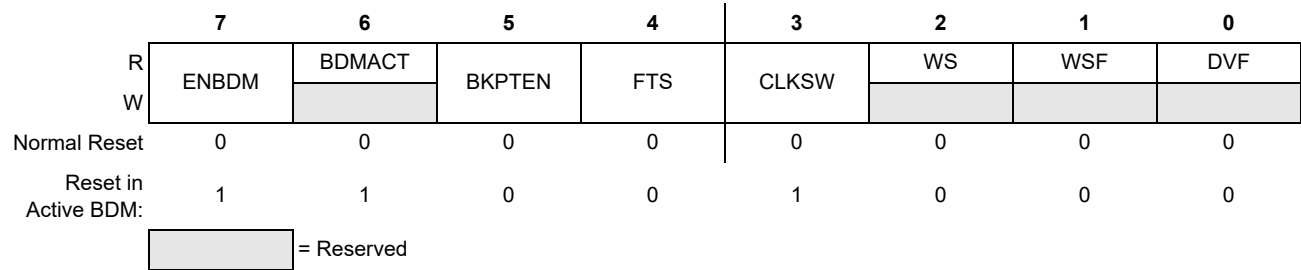

Figure 118. BDC Status and Control Register (BDCSCR)

Table 91. BDCSCR Register Field Descriptions

Field	Description
7 ENBDM	Enable BDM (Permit ACTIVE BACKGROUND Mode) — Typically, this bit is written to 1 by the debug host shortly after the beginning of a debug session or whenever the debug host resets the target and remains 1 until a normal reset clears it. 0 BDM cannot be made active (non-intrusive commands still allowed) 1 BDM can be made active to allow ACTIVE BACKGROUND mode commands
6 BDMACT	BACKGROUND Mode Active Status — This is a read-only status bit. 0 BDM not active (user application program running) 1 BDM active and waiting for serial commands
5 BKPTEN	BDC Breakpoint Enable — If this bit is clear, the BDC breakpoint is disabled and the FTS (force tag select) control bit and BDCBKPT match register are ignored. 0 BDC breakpoint disabled 1 BDC breakpoint enabled
4 FTS	Force/Tag Select — When FTS = 1, a breakpoint is requested whenever the CPU address bus matches the BDCBKPT match register. When FTS = 0, a match between the CPU address bus and the BDCBKPT register causes the fetched opcode to be tagged. If this tagged opcode ever reaches the end of the instruction queue, the CPU enters ACTIVE BACKGROUND mode rather than executing the tagged opcode. 0 Tag opcode at breakpoint address and enter ACTIVE BACKGROUND mode if CPU attempts to execute that instruction 1 Breakpoint match forces ACTIVE BACKGROUND mode at next instruction boundary (address need not be an opcode)
3 CLKSW	Select Source for BDC Communications Clock — CLKSW defaults to 0, which selects the alternate BDC clock source. 0 Alternate BDC clock source 1 MCU bus clock
2 WS	WAIT or STOP Status — When the target CPU is in WAIT or STOP mode, most BDC commands cannot function. However, the BACKGROUND command can be used to force the target CPU out of WAIT or STOP and into ACTIVE BACKGROUND mode where all BDC commands work. Whenever the host forces the target MCU into ACTIVE BACKGROUND mode, the host should issue a READ_STATUS command to check that BDMACT = 1 before attempting other BDC commands. 0 Target CPU is running user application code or in ACTIVE BACKGROUND mode (was not in WAIT or STOP mode when BACKGROUND became active) 1 Target CPU is in WAIT or STOP mode, or a BACKGROUND command was used to change from WAIT or STOP to ACTIVE BACKGROUND mode
1 WSF	WAIT or STOP Failure Status — This status bit is set if a memory access command failed due to the target CPU executing a WAIT or STOP instruction at or about the same time. The usual recovery strategy is to issue a BACKGROUND command to get out of WAIT or STOP mode into ACTIVE BACKGROUND mode, repeat the command that failed, then return to the user program. (Typically, the host would restore CPU registers and stack values and re-execute the WAIT or STOP instruction.) 0 Memory access did not conflict with a WAIT or STOP instruction 1 Memory access command failed because the CPU entered WAIT or STOP mode
0 DVF	Data Valid Failure Status — This status bit is not used in the MC9S08RA16 because it does not have any slow access memory. 0 Memory access did not conflict with a slow memory access 1 Memory access command failed because CPU was not finished with a slow memory access

15.3.3 BDC Breakpoint Match Register (BDCBKPT)

This 16-bit register holds the address for the hardware breakpoint in the BDC. The BKPTEN and FTS control bits in BDCSCR are used to enable and configure the breakpoint logic. Dedicated serial BDC commands (READ_BKPT and WRITE_BKPT) are used to read and write the BDCBKPT register but is not accessible to user programs because it is not located in the normal memory map of the MCU. Breakpoints are normally set while the target MCU is in ACTIVE BACKGROUND mode before running the user application program. For additional information about setup and use of the hardware breakpoint logic in the BDC, refer to [Section 15.2.4](#).

15.3.4 System Background Debug Force Reset Register (SBDFR)

This register contains a single write-only control bit. A serial BACKGROUND mode command such as WRITE_BYTE must be used to write to SBDFR. Attempts to write this register from a user program are ignored. Reads always return 0x00.

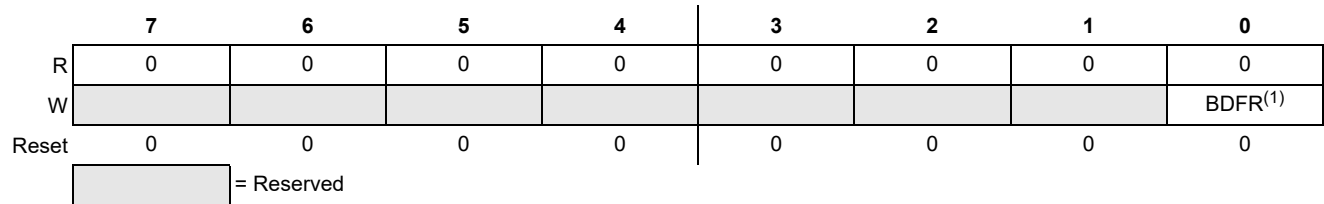

1. BDFR is writable only through serial BACKGROUND mode debug commands, not from user programs.

Figure 119. System Background Debug Force Reset Register (SBDFR)

Table 92. SBDFR Register Field Description

Field	Description
0 BDFR	Background Debug Force Reset — A serial ACTIVE BACKGROUND mode command such as WRITE_BYTE allows an external debug host to force a target system reset. Writing 1 to this bit forces an MCU reset. This bit cannot be written from a user program.

16 Battery Charge Consumption Modeling

The supply current consumed by the FXTH870x6 can be estimated using the following basic model.

16.1 Standby Current

The overall charge consumed by the standby features is:

$$Q_{\text{STDBY}} = t_{\text{TOT}} \times \frac{(I_{\text{STDBY}} + I_{\text{LF}})}{1000} \quad \text{Eqn. 12}$$

where:

Q_{STDBY} = Standby charge over lifetime, t_{TOT} , in mA-hr
 t_{TOT} = Total lifetime in hours
 I_{STDBY} = General standby current in μA
 I_{LF} = LFR detector (if used) current in μA

16.2 Measurement Events

The overall charge consumed by the measurements is:

$$Q_{\text{MEAS}} = \frac{1}{1000} \times (n_{\text{PRESS}} \times Q_{\text{PRESS}} + n_{\text{TEMP}} \times Q_{\text{TEMP}} + n_{\text{VOLT}} \times Q_{\text{VOLT}}) \quad \text{Eqn. 13}$$

where:

Q_{MEAS} = Total measurement charge over lifetime in mA-sec
 Q_{PRESS} = Measurement charge per pressure measurement in $\mu\text{A-sec}$
 Q_{TEMP} = Measurement charge per temperature measurement in $\mu\text{A-sec}$
 Q_{VOLT} = Measurement charge per voltage measurement in $\mu\text{A-sec}$
 n_{PRESS} = Total number of pressure measurements over lifetime
 n_{TEMP} = Total number of temperature measurements over lifetime
 n_{VOLT} = Total number of voltage measurements over lifetime

16.3 Transmission Events

The overall charge consumed by the transmissions is:

$$Q_{\text{XMT}} = \frac{Q_{\text{FRM}}}{1000} \times F \times n_{\text{XMT}} \quad \text{Eqn. 14}$$

where:

Q_{XMT} = Transmit charge over lifetime, t_{TOT} , in mA-hr
 Q_{FRM} = Transmit charge per frame of data in $\mu\text{A-sec}$
 n_{XMT} = Number of transmissions over lifetime
 F = Frames transmitted during each datagram

16.4 Total Consumption

The overall charge consumed is:

$$Q_{\text{TOT}} = \frac{(Q_{\text{STDBY}} + Q_{\text{MEAS}} + Q_{\text{XMT}})}{(1 - Y \times \text{SD}/100)} \quad \text{Eqn. 15}$$

where:

Q_{TOT} = Total charge over lifetime, t_{TOT} , in mA-hr
 Q_{STDBY} = Standby charge over lifetime in mA-hr
 Q_{MEAS} = Measurement charge over lifetime in mA-hr
 Q_{XMT} = Transmit charge over lifetime in mA-hr
 Y = Lifetime in years
 SD = Battery self-discharge rate in%/year

Additional margin in battery capacity can be added to the calculated value of Q_{TOT} .

17 Electrical Specifications

17.1 Maximum Ratings

Maximum ratings are the extreme limits to which the device can be exposed without permanently damaging it. The device contains circuitry to protect the inputs against damage from high static voltages; however, do not apply voltages higher than those shown in the table below. Keep V_{IN} and V_{OUT} within the range $V_{SS} \leq (V_{IN} \text{ or } V_{OUT}) \leq V_{DD}$.

#	Rating	Symbol	Value	Unit	
100	Supply Voltage (V_{DD} , AV_{DD})	V_{DD}	-0.3 to +3.8	V	(3)
101	Input Voltage X1	V_{IN}	-0.3 to $V_{DD}+0.3$	V	(3)
102	PTA0, PTA1, PTA2, PTA3, PTB0, PTB1	V_{IN}	-0.3 to $V_{DD}+0.3$	V	(3)
103	BKGD/PTA4, $\overline{\text{RESET}}$	V_{IN}	-0.3 to $V_{DD}+0.3$	V	(3)
104	LFA, LFB	V_{IN}	-0.3 to $V_{DD}+0.3$	V	(3)
105	Input Current X1	I_{IN}	± 10	mA	(3)
106	PTA0, PTA1, PTA2, PTA3, PTB0, PTB1	I_{IN}	± 10	mA	(3)
107	BKGD/PTA4, $\overline{\text{RESET}}$	I_{IN}	± 10	mA	(3)
108	LFA, LFB	I_{IN}	± 10	mA	(3)
109	Substrate Current Injection Current from any pin to V_{SS} - 0.3 VDC XI, PTA0, PTA1, PTA2, PTA3, PTB0, PTB1, BKGD/PTA4, $\overline{\text{RESET}}$	I_{SUB}	600	μA	(3)
110	LFA, LFB	I_{SUB}	2	mA	(3)
111	Latchup Current Current to/from any pin to supply rails + 0.3 VDC	I_{LATCH}	± 100	mA	(3)
112	Electrostatic Discharge Human Body Model (HBM), all pins other than RF	V_{ESD}	± 2000	V	(3)
113	Human Body Model (HBM), RF pin	V_{ESD}	± 3000	V	(3)
114	Charged Device Model (CDM)	V_{ESD}	± 500	V	(3)
115	Maximum Storage Temperature Range	T_{stg}	-50 to +150	$^{\circ}\text{C}$	(3)

Note: Refer to [page 169](#) for description of notes.

17.2 Operating Range

The limits normally expected in the application which define range of operation.

#	Characteristic	Symbol	Min	Typ	Max	Units	
	Operating Supply Voltage ($V_{DD} = AV_{DD}$)		V_L		V_H		
	Measurements						
200	Pressure, Temperature, Acceleration	V_{DD}	2.3	3.0	3.6	V	(2)
201	Voltage	V_{DD}	1.8	3.0	3.6	V	(2)
202	LFR Operation ($-20 < T_A < +85^{\circ}\text{C}$)	V_{DD}	2.3	3.0	3.6	V	(2)
203	RF Transmissions	V_{DD}	1.8	3.0	3.6	V	(2)
	MCU operation (CPU, ADC10, RAM, TPM1)						
204	FLASH write (-40 to $+125^{\circ}\text{C}$)	V_{DD}	2.3	3.0	3.6	V	(2)
205	FLASH write (-20 to $+85^{\circ}\text{C}$)	V_{DD}	2.1	3.0	3.6	V	(2)
206	FLASH read	V_{DD}	1.8	3.0	3.6	V	(2)
207	Parameter registers data retention	V_{DD}	1.2	—	—	V	(2)
	Operating Temperature Range		T_L		T_H		
208	Continuous Temperature Range	T_A	-40	—	+125	$^{\circ}\text{C}$	(3)
209	STOP1 mode (note 5)	T_A	-40	—	+150	$^{\circ}\text{C}$	(3)

Note: Refer to [page 169](#) for description of notes.

17.3 Electrical Characteristics

$1.8 \leq V_{DD} \leq 3.6$, $T_L \leq T_A \leq T_H$, unless otherwise specified.

#	Characteristic	Symbol	Min	Typ	Max	Units	
300	Output High Voltage ($I_{Load} = 5 \text{ mA}$) PTA0, PTA1, PTA2, PTA3, PTB0, PTB1	V_{OH}	$V_{DD}-0.35$	—	—	V	(2)
301	Output Low Voltage ($I_{Load} = -5 \text{ mA}$) PTA0, PTA1, PTA2, PTA3, PTB0, PTB1	V_{OL}	—	—	0.35	V	(2)
302	Input High Voltage ($2.3 < V_{DD} \leq V_H$) PTA0, PTA1, PTA2, PTA3, PTB0, PTB1, BKGD/PTA4	V_{IH}	$0.7 \times V_{DD}$	—	—	V	(2)
303	Input High Voltage ($V_L \leq V_{DD} \leq 2.3$) PTA0, PTA1, PTA2, PTA3, PTB0, PTB1, BKGD/PTA4	V_{IH}	$0.85 \times V_{DD}$	—	—	V	(3)
304	Input Low Voltage ($2.3 < V_{DD} \leq V_H$) PTA0, PTA1, PTA2, PTA3, PTB0, PTB1, BKGD/PTA4	V_{IL}	V_{SS}	—	$0.35 \times V_{DD}$	V	(2)
305	Input Low Voltage ($V_L \leq V_{DD} \leq 2.3$) PTA0, PTA1, PTA2, PTA3, PTB0, PTB1, BKGD/PTA4	V_{IL}	V_{SS}	—	$0.28 \times V_{DD}$	V	(3)
306	Input High Current (at min V_{IH}) BKGD/PTA4	I_{IH}	-1	—	+1	μA	(1)
307	PTA0, PTA1, PTA2, PTA3 (pulldown off)	I_{IH}	-1	—	+1	μA	(2)
308	PTA0, PTA1, PTA2, PTA3 (pulldown active)	I_{IH}	0	—	+120	μA	(2)
309	Input Low Current (at max V_{IL}) BKGD/PTA4	I_{IL}	-120	—	0	μA	(1)
310	PTA0, PTA1, PTA2, PTA3, PTB0, PTB1 (pullup off)	I_{IL}	-1	—	+1	μA	(2)
311	PTA0, PTA1, PTA2, PTA3 (pullup active)	I_{IL}	-120	—	0	μA	(2)
312	Pin Capacitance (3 V) BKGD/PTA4, PTA0, PTA1, PTA2, PTA3, PTB0, PTB1	C	0	—	15	pF	(3)

Note: Refer to [page 169](#) for description of notes.

17.4 Power Consumption (MCU)

$1.8 \leq V_{DD} \leq 3.6$, $T_A = -40$ to 125 °C unless otherwise specified.

#	Characteristic	Symbol	Min	Typ	Max	Units	
	Standby Supply Current STOP1 mode, LFR, LVD and TR all off						
400	$T_A = -40$ °C, $V_{DD} = 3.0$ V	I_{STDBY1}	—	—	0.9	μ A	(3)
401	$T_A = 0$ °C, $V_{DD} = 3.0$ V	I_{STDBY1}	—	—	0.9	μ A	(3)
402	$T_A = 25$ °C, $V_{DD} = 1.8$ V	I_{STDBY1}	—	—	0.8	μ A	(3)
403	$T_A = 25$ °C, $V_{DD} = 3.0$ V	I_{STDBY1}	—	0.5	0.7	μ A	(2)
404	$T_A = 25$ °C, $V_{DD} = 3.6$ V	I_{STDBY1}	—	—	0.9	μ A	(3)
405	$T_A = 70$ °C, $V_{DD} = 3.0$ V	I_{STDBY1}	—	—	1.5	μ A	(3)
406	$T_A = 125$ °C, $3.0 \text{ V} \leq V_{DD} \leq 3.6 \text{ V}$	I_{STDBY1}	—	—	13	μ A	(3)
	Standby Supply Current STOP4 mode, LFR and TR off, LVD or RFLVD on						
407	$T_A = -40$ °C, $V_{DD} = 3.0$ V	I_{STDBY4}	—	—	100	μ A	(3)
408	$T_A = 0$ °C, $V_{DD} = 3.0$ V	I_{STDBY4}	—	—	100	μ A	(3)
409	$T_A = 25$ °C, $V_{DD} = 1.8$ V	I_{STDBY4}	—	—	95	μ A	(3)
410	$T_A = 25$ °C, $V_{DD} \geq 3.0$ V	I_{STDBY4}	—	73	95	μ A	(2)
411	$T_A = 70$ °C, $V_{DD} = 3.0$ V	I_{STDBY4}	—	—	100	μ A	(3)
412	$T_A = 125$ °C, $3.0 \text{ V} \leq V_{DD} \leq 3.6 \text{ V}$	I_{STDBY4}	—	—	140	μ A	(3)
	MCU Operate Current ($1.8 \leq V_{DD} \leq 3.0 \text{ V}$, -40 °C $\leq T_A \leq 125$ °C) Instruction Speed = $0.333 \text{ MIP}/f_{BUS}$						
413	0.5 MHz f_{BUS} , $BUSCLKS[1:0] = 11$	I_{DD}	—	0.72	1.0	mA	(3)
414	1 MHz f_{BUS} , $BUSCLKS[1:0] = 10$	I_{DD}	—	0.94	1.1	mA	(3)
415	2 MHz f_{BUS} , $BUSCLKS[1:0] = 01$	I_{DD}	—	1.46	1.7	mA	(3)
416	4 MHz f_{BUS} , $BUSCLKS[1:0] = 00$	I_{DD}	—	2.50	2.9	mA	(1)
	Standby Current Adder for Temperature Restart						
417	$V_{DD} = 1.8 \text{ V}$, $T_A = 125$ °C	ΔI_{DD}	—	10	15	μ A	(3)
418	$V_{DD} = 3.0 \text{ V}$, $T_A = 125$ °C	ΔI_{DD}	—	10	15	μ A	(3)
	MCU Wakeup Consumption (+25 °C, 3 V) From STOP1 to first instruction, $f_{BUS} = 4 \text{ MHz}$						
419		Q_{WAKE}	0	0.05	0.1	μ A-sec	(3)
	External Battery Model						
420	Series impedance at end-of-life	Z_{EOL}	—	—	60	Ω	(4)
421	Open circuit voltage at end-of-life	V_{EOL}	2.7	—	—	V	(4)

Note: Refer to [page 169](#) for description of notes.

17.5 Control Timing

$1.8 \leq V_{DD} \leq 3.6$, $T_L \leq T_A \leq T_H$, unless otherwise specified.

#	Characteristic	Symbol	Min	Typ	Max	Units	
500	Internal Clock Frequency						
	Initial startup frequency	$f_{OSCINIT}$	6	8	10	MHz	(3)
501	Final frequency						
502	Limited temperature range, -20 °C to +85 °C	f_{OSC}	7.2	—	8.1	MHz	(2)
503	Full temperature range, -40 °C to +125 °C	f_{OSC}	6.8	—	8.1	MHz	(3)
504	Complete stabilization time (see Figure 120)	t_{OSCSU}	—	300	1000	μ sec	(3)
505	MCU Bus Frequency	f_{BUS}	—	$0.5 f_{OSC}$	—	MHz	(2)
506	Medium frequency clock (MFO)						
	Limited temperature range, -20 °C to +85 °C	f_{MFO}	115	125	128	kHz	(2)
507	Full temperature range, -40 °C to +125 °C	f_{MFO}	106	—	128	kHz	(3)
508	Low frequency clock (LFO)						
	Limited temperature range, 0 °C to +70 °C	f_{LFO}	833	—	1250	Hz	(2)
509	Full temperature range, -40 °C to +125 °C	f_{LFO}	770	—	1429	Hz	(3)
510	LFR clock (derived from LFRO)	f_{LFRO}	122	129	135	kHz	(1)
511	Power-On Reset Response						
	Supply voltage rise time	t_{VDDR}	—	—	1	sec	(3)
512	Recovery time below $V_{DD} = 0.5$ V	t_{VDDOFF}	0	—	70	μ sec	(3)
513	MCU Wakeup Time (see Figure 120)						
	From STOP1 to first instruction, $f_{BUS} = 4$ MHz	$t_{MCUWAKE}$	—	50	70	μ sec	(3)
514	From STOP4 to first instruction, $f_{BUS} = 4$ MHz	$t_{MCUWAKE}$	—	100	155	μ sec	(3)
515	FLASH Data Retention Time	t_{DR}	10	—	—	year	(4)

Note: Refer to page 169 for description of notes.

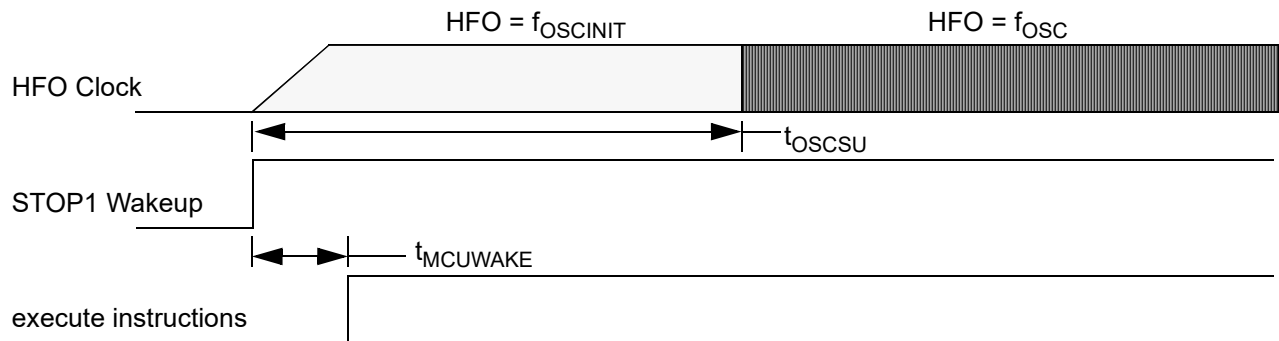

Figure 120. MCU Startup Delays

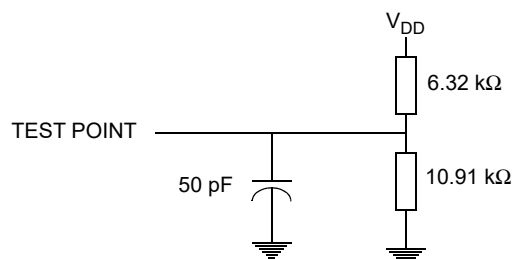

Figure 121. Control Timing Test Load for Digital Pins

17.6 Voltage Measurement Characteristics

$1.8 \leq V_{DD} \leq 3.6$, $T_L \leq T_A \leq T_H$, unless otherwise specified.

#	Characteristic	Symbol	Min	Typ	Max	Units	
600	Lower LVD detect threshold (note 15) V_{DD} falling	V_{LVDL}	1.79	1.88	1.96	V	(2)
601	V_{DD} rising	V_{LVDL}	1.87	—	2.03	V	(3)
602	Voltage drop detection time (note 16)	t_{LVDL}	—	—	10	μ sec	(3)
603	Higher LVD detect threshold (note 15) V_{DD} falling	V_{LVDH}	2.05	—	2.3	V	(1)
604	V_{DD} rising	V_{LVDH}	2.12	—	2.3	V	(3)
605	Voltage drop detection time (note 16)	t_{LVDH}	—	—	10	μ sec	(3)
606	Lower LVW detect threshold (LVWV = 0, note 15) V_{DD} falling	V_{LVWL}	2.05	—	2.3	V	(1)
607	V_{DD} rising	V_{LVWL}	2.12	—	2.3	V	(3)
608	Voltage drop detection time (note 16)	t_{LVWL}	—	—	10	μ sec	(3)
609	Higher LVW detect threshold (LVWV = 1, note 15) V_{DD} falling	V_{LVWH}	2.28	—	2.54	V	(1)
610	V_{DD} rising	V_{LVWH}	2.34	—	2.61	V	(3)
611	Voltage drop detection time (note 16)	t_{LVWH}	—	—	10	μ sec	(3)
612	RF LVD detect threshold, V_{DD} falling (note 15)	V_{LVDRF}	1.60	1.79	1.95	V	(2)
613	Voltage drop detection time (note 16)	t_{LVDRF}	—	—	10	μ sec	(3)
614	Power-On Reset Voltage (note 15) Rising Voltage to Recover	V_{PORR}	—	—	2.1	V	(3)
615	Falling Voltage to Reset	V_{PORF}	0.8	—	—	V	(3)
616	Internal Voltage (V_{DD} , monotonic response). $V_{CODE} = 0$	V_{INT}	—	FAULT	—	V	(3)
617	= 58	V_{INT}	1.6	1.8	2.0	V	(3)
618	= 88	V_{INT}	2.0	2.1	2.2	V	(3)
619	= 108	V_{INT}	2.2	2.3	2.4	V	(3)
620	= 128	V_{INT}	2.4	2.5	2.6	V	(3)
621	= 158	V_{INT}	2.7	2.8	2.9	V	(1)
622	= 208	V_{INT}	3.2	3.3	3.4	V	(3)
623	= 238	V_{INT}	3.5	3.6	3.7	V	(3)
624	= 255	V_{INT}	—	FAULT	—	V	(3)
625	Voltage sensitivity	ΔV_{INT}	—	10	—	mV/count	(3)
626	External Voltage (PTA[1:0], monotonic response, conversion is ratiometric to V_{DD}) Gx_{CODE} , where x = 0, 1 refers to PTA0 or PTA1	n	—	1023 (V_{IN}/V_{DD})	—	count	(4)
627	Voltage sensitivity	ΔV_{EXT}	—	$V_{DD}/1023$	—	V/count	(4)
628	ADC INL	INL	-1	—	+1	LSB	(3)
629	ADC DNL	DNL	-1	—	+1	LSB	(3)
630	Voltage Measurement (internal voltage or external pin) Sensor measurement time (note 7)	t_{VM}	—	0.45	0.53	ms	(3)
631	Peak current (note 8)	I_V	—	3.2	3.9	mA	(3)
632	Power consumption (note 22) Raw measurement, 10-bit	Q_V	—	0.13	0.3	μ A-sec	(3)
633	Compensation, 8-bit	Q_V	—	0.40	0.64	μ A-sec	(3)
634	Basic compensated reading, 8-bit	Q_V	—	0.53	0.9	μ A-sec	(3)
635	Full compensated reading, 8-bit	Q_V	—	0.53	0.9	μ A-sec	(3)

Note: Refer to [page 169](#) for description of notes

17.7 Temperature Measurement Characteristics

$2.3 \leq V_{DD} \leq 3.6$, $T_L \leq T_A \leq T_H$, unless otherwise specified.

#	Characteristic	Symbol	Min	Typ	Max	Units	
700	Temperature measurement (monotonic response) (note 11)						
	$T_{CODE} = 0$	T	—	FAULT	—	°C	(3)
701	= 15	T	-45	-40	-35	°C	(3)
702	= 35	T	-23	-20	-17	°C	(1)
703	= 55	T	-3	0	3	°C	(3)
704	= 84	T	26	29	32	°C	(3)
705	= 125	T	67	70	73	°C	(3)
706	= 140	T	81	85	89	°C	(1)
707	= 180	T	120	125	130	°C	(3)
708	= 255	T	—	FAULT	—	°C	(3)
709	Temperature sensitivity	ΔT	—	1.0	—	°C/count	(3)
710	Temperature measurement stability range (note 10)	T_{STAB}	—	—	2	count	(3)
	Thermal Shutdown Recovery (TRE = 1)						
711	High Re-Arming Temperature (TRH = 1, note 13)	T_{REARMH}	—	—	125	°C	(4)
712	High Reset Temperature (TRH = 1)	T_{RESETH}	95	—	—	°C	(4)
713	Low Re-Arming Temperature (TRH = 0, note 13)	T_{REARML}	-90	—	—	°C	(4)
714	Low Reset Temperature (TRH = 0)	T_{RESETL}	—	—	4	°C	(4)
	Temperature Measurement						
715	Sensor measurement time (note 7)	t_{TM}	—	0.6	0.7	ms	(3)
716	Peak current (note 8)	I_T	—	3.0	3.9	mA	(3)
	Power consumption (note 22)						
717	Raw measurement, 12-bit	Q_T	—	0.19	0.3	μA -sec	(3)
718	Compensation, 8-bit	Q_T	—	0.43	0.6	μA -sec	(3)
719	Basic compensated reading, 8-bit	Q_T	—	0.62	0.82	μA -sec	(3)
720	Full compensated reading, 8-bit	Q_T	—	0.62	0.82	μA -sec	(3)

Note: Refer to [page 169](#) for description of notes.

17.8 Pressure Measurement Characteristic (100 to 450 kPa ranges)

$2.3 \leq V_{DD} \leq 3.6$, $T_L \leq T_A \leq T_H$, unless otherwise specified.

Pressure accuracy specified for pressure drops slower than 1 kPa/sec.

#	Characteristic	Symbol	Min	Typ	Max	Units	
	Pressure Measurement (note 6) $0\text{ }^\circ\text{C} \leq T_A \leq +70\text{ }^\circ\text{C}$						
800	$P_{\text{CODE}} = 0$	P	—	FAULT	—	kPa	(3)
801	= 1	P	93	100	107	kPa	(4)
802	= 10	P	100	107	114	kPa	(3)
803	= 255	P	268	275	282	kPa	(3)
804	= 499	P	436	443	450	kPa	(3)
805	= 510	P	443	450	457	kPa	(4)
806	= 511	P	—	FAULT	—	kPa	(3)
	$-20\text{ }^\circ\text{C} \leq T_A < 0\text{ }^\circ\text{C}$, $70\text{ }^\circ\text{C} < T_A \leq 85\text{ }^\circ\text{C}$						
807	$P_{\text{CODE}} = 0$	P	—	FAULT	—	kPa	(3)
808	= 1	P	89.5	100	110.5	kPa	(4)
809	= 10	P	96.5	107	117.5	kPa	(3)
810	= 255	P	264.5	275	285.5	kPa	(1)
811	= 499	P	432.5	443	453.5	kPa	(3)
812	= 510	P	439.5	450	460.5	kPa	(4)
813	= 511	P	—	FAULT	—	kPa	(3)
	$-40\text{ }^\circ\text{C} \leq T_A < -20\text{ }^\circ\text{C}$, $85\text{ }^\circ\text{C} < T_A \leq 125\text{ }^\circ\text{C}$						
814	$P_{\text{CODE}} = 0$	P	—	FAULT	—	kPa	(3)
815	= 1	P	83.2	100	116.8	kPa	(4)
816	= 10	P	90.2	107	123.8	kPa	(3)
817	= 255	P	258.2	275	291.8	kPa	(3)
818	= 499	P	426.2	443	459.8	kPa	(3)
819	= 510	P	433.2	450	466.8	kPa	(4)
820	= 511	P	—	FAULT	—	kPa	(3)
821*	Pressure Sensitivity	ΔP_{RANGE}	—	0.688	—	kPa/count	(3)
822**	Pressure Measurement Stability Range	P_{STAB}	—	—	6	count	(3)

* FSL D-FMEA class 163.

** FSL D-FMEA class 164.

Note: Refer to [page 169](#) for description of notes.

17.9 Pressure Measurement Characteristic (100 to 900 kPa ranges)

$2.3 \leq V_{DD} \leq 3.6$, $T_L \leq T_A \leq T_H$, unless otherwise specified.

Pressure accuracy specified for pressure drops slower than 1 kPa/sec.

#	Characteristic	Symbol	Min	Typ	Max	Units	
	Pressure Measurement (note 6) $0\text{ }^\circ\text{C} \leq T_A \leq +70\text{ }^\circ\text{C}$						
900	$P_{CODE} = 0$	P	—	FAULT	—	kPa	(3)
901	= 1	P	90	100	110	kPa	(4)
902	= 10	P	106	116	126	kPa	(3)
903	= 255	P	491	501	511	kPa	(3)
904	= 499	P	874	884	894	kPa	(3)
905	= 510	P	890	900	910	kPa	(4)
906	= 511	P	—	FAULT	—	kPa	(3)
	$-20\text{ }^\circ\text{C} \leq T_A < 0\text{ }^\circ\text{C}$, $70\text{ }^\circ\text{C} < T_A \leq 85\text{ }^\circ\text{C}$						
907	$P_{CODE} = 0$	P	—	FAULT	—	kPa	(3)
908	= 1	P	85	100	115	kPa	(4)
909	= 10	P	101	116	131	kPa	(3)
910	= 255	P	486	501	516	kPa	(1)
911	= 499	P	869	884	899	kPa	(3)
912	= 510	P	885	900	915	kPa	(4)
913	= 511	P	—	FAULT	—	kPa	(3)
	$-40\text{ }^\circ\text{C} \leq T_A < -20\text{ }^\circ\text{C}$, $85\text{ }^\circ\text{C} < T_A \leq 125\text{ }^\circ\text{C}$						
914	$P_{CODE} = 0$	P	—	FAULT	—	kPa	(3)
915	= 1	P	76	100	124	kPa	(4)
916	= 10	P	92	116	140	kPa	(3)
917	= 255	P	477	501	525	kPa	(3)
918	= 499	P	860	884	908	kPa	(3)
919	= 510	P	876	900	924	kPa	(4)
920	= 511	P	—	FAULT	—	kPa	(3)
921*	Pressure Range	ΔP_{RANGE}	—	1.572	—	kPa/count	(3)
922**	Pressure Measurement Stability Range	P_{STAB}	—	—	4	count	(3)
	Pressure Sensitivity to Z-Axis Acceleration (note 12)						
923	0-500g	P_{ACC}	0	—	0	Pa/g	(3)
924	>500g	P_{ACC}	-6.5	-4.5	-2	Pa/g	(3)
	Pressure Measurement						
925	Sensor measurement time (note 7)	t_{PM}	—	4.0	4.4	ms	(3)
926	Peak current (note 8)	I_P	—	3.0	3.4	mA	(3)
	Power consumption (note 22)						
927	Raw measurement, 10-bit	Q_P	—	2.1	3.25	$\mu\text{A-sec}$	(3)
928	Compensation, 9-bit	Q_P	—	1.8	2.3	$\mu\text{A-sec}$	(3)
929	Basic compensated reading, 9-bit	Q_P	—	3.9	5.3	$\mu\text{A-sec}$	(3)
930	Full compensated reading	Q_P	—	4.3	5.85	$\mu\text{A-sec}$	(3)

* FSL D-FMEA class 194.

**FSL D-FMEA class 195.

Note: Refer to [page 169](#) for description of notes.

17.10 Optional Acceleration Sensor Characteristics

17.10.1 Example Z-Axis Acceleration Sensor Calculations (similar for X-Axis)

As an example, consider that the dynamic firmware routine has returned STEP = 6 indicating offset step 6, and $A_{ZCODE} = 256$. First, refer to lines 1001 and 1009 to retrieve the step number 6 values for $A_{ZCODE} = 510$ and for $A_{ZCODE} = 1$. Then apply the following to calculate the sensitivity for offset step 6:

$$\begin{aligned}\Delta A_{Z-6} &= (A_{Z-6} @ A_{ZCODE}^{510} - A_{Z-6} @ A_{ZCODE}^1) / 510 \\ &= (42.1 - (-42.9)) / 510 \\ &= 0.167 \text{ g per } A_{ZCODE} \text{ integer}\end{aligned}$$

Eqn. 16

Once the sensitivity ΔA_{Z-6} has been calculated, the acceleration A_Z can be calculated with the following transfer function:

$$\begin{aligned}A_Z &= \Delta A_{Z-6} \times A_{ZCODE} + (A_{Z-6} @ A_{ZCODE}^1 - \Delta A_{Z-6}) \\ &= 0.167 \times 256 + (-42.9 - 0.167) \\ &= \sim -0.3 \text{ g}\end{aligned}$$

Eqn. 17

Another example where STEP has been returned as 15 and A_{ZCODE} has been returned as 256:

$$\begin{aligned}\Delta A_{Z-15} &= (A_{Z-15} @ A_{ZCODE}^{510} + A_{Z-15} @ A_{ZCODE}^1) / 510 \\ &= (402 - 315) / 510 \\ &= 0.171 \text{ g per } A_{ZCODE} \text{ integer}\end{aligned}$$

Eqn. 18

Then:

$$\begin{aligned}A_Z &= \Delta A_{Z-15} \times A_{ZCODE} + (A_{Z-15} @ A_{ZCODE}^1 - \Delta A_{Z-15}) \\ &= 0.171 \times 256 + (315 - 0.171) \\ &= \sim 359 \text{ g}\end{aligned}$$

Eqn. 19

17.10.2 Acceleration Measurement Characteristics (Z and X ranges)

$2.3 \leq V_{DD} \leq 3.6$, $T_L \leq T_A \leq T_H$, unless otherwise specified.

Acceleration accuracy specified for pressure drops slower than 1 kPa/sec.

Note: Refer to [page 169](#) for description of notes.

#	Characteristic	Symbol	FXTH870x02 family (Z-axis)			FXTH870x11 family (Z-axis)			FXTH870x11 family (X-axis)			Units		
			Min	Typ	Max	Min	Typ	Max	Min	Typ	Max			
1000	Acceleration Measurement (note 9) $A_{CODE} = 0$	A_6	—	FAULT	—	—	FAULT	—	—	FAULT	—	g	(3)	
1001	= 1	A_6	-51.9	-42.9	-33.2	See Offset STEP = 7			See Offset STEP = 7			g	(3)	
1002	= 16	A_6	-49.2	-40.4	-31.1							g	(3)	
1003	= 196	A_6	-14.7	-10.3	-5.7							g	(3)	
1004	= 250	A_6	-4.2	-1	2.1							g	(3)	
1005	= 256	A_6	-3	0	3							g	(1)	
1006	= 262	A_6	-2.1	1	4.2							g	(3)	
1007	= 316	A_6	5.4	9.7	14.4							g	(3)	
1008	= 496	A_6	31.2	39.8	49.3							g	(3)	
1009	= 510	A_6	33.0	42.1	51.8							g	(3)	
1010	= 511	A_6	—	FAULT	—							—	FAULT	—
1011	Average Accel Sensitivity (1 to 510 counts)	$\Delta A_{average}$	—	0.167	—	—	0.118	—	—	0.039	—	g/count	(3)	
1012	Average Offset step at acceleration output = 256. $V_{DD} = 3 V$	A_{INCR}	37	39.5	42	—	30	—	—	10	—	g/Offset Step	(3)	
1013	Acceleration measurement stability range (note 10)	A_{STAB}	—	—	4	—	—	5	—	—	4	count	(3)	
1014	Minimum range of acceleration measurement for each offset code. Average Offset STEP= 0	A_0											g	(3)
1015	$A_{CODE} = 1$		-304	-271	238	—	-210	—	—	-80	—			
1016	= 256		—	-231	—	—	-180	—	—	-70	—			
1017	= 510		-215	-191	-167	—	-150	—	—	-60	—			
1018	Offset STEP = 1	A_1											g	(3)
1019	$A_{CODE} = 1$		-264	-234	-204	—	-180	—	—	-70	—			
1020	= 256		—	-193	—	—	-150	—	—	-60	—			
1021	= 510		-173	-153	-133	—	-120	—	—	-50	—			
1022	Offset STEP = 2	A_2											g	(3)
1023	$A_{CODE} = 1$		-223	-197	170	—	-150	—	—	-60	—			
1024	= 256		—	-156	—	—	-120	—	—	-50	—			
1025	= 510		-132	-114	97	—	-90	—	—	-40	—			
1026	Offset STEP = 3	A_3											g	(3)
1027	$A_{CODE} = 1$		-181	-158	-136	—	-120	—	—	-50	—			
1028	= 256		—	-117	—	—	-90	—	—	-40	—			
1029	= 510		-88	-75	-62	—	-60	—	—	-30	—			
1030	Offset STEP = 4	A_4											g	(3)
1031	$A_{CODE} = 1$		-140	-120	-100	—	-90	—	—	-40	—			
1032	= 256		—	-78	—	—	-60	—	—	-30	—			
1033	= 510		-48	-36	-24	—	-30	—	—	-20	—			
1034	Offset STEP = 5	A_5											g	(3)
1035	$A_{CODE} = 1$		-88	-81	-74	—	-60	—	—	-30	—			
1036	= 256		-45	-39	-33	—	-30	—	—	-20	—			
1037	= 510		-2	4	9	—	0	—	—	-10	—			
1038	Offset STEP = 6	A_6											g	(3)
1039	$A_{CODE} = 1$		See lines 1001-1009			—	-30	—	—	-20	—			
1040	= 256					—	0	—	—	-10	—			
1041	= 510					—	30	—	—	0	—			

#	Characteristic	Symbol	FXTH870x02 family (Z-axis)			FXTH870x11 family (Z-axis)			FXTH870x11 family (X-axis)			Units	
			Min	Typ	Max	Min	Typ	Max	Min	Typ	Max		
1042	Offset STEP = 7	A ₇	-10	-5	1	-3	0	+3	-14	-10	-6	g	(3)
1043	A _{CODE} = 1		32	38	44	22	30	38	-3	0	+3		
1044	= 256		74	80	87	46	60	74	6	10	14		
1045	= 510												
1046	Offset STEP = 8	A ₈	23	35	47	—	30	—	—	0	—	g	(3)
1047	A _{CODE} = 1		—	78	—	—	60	—	—	10	—		
1048	= 256		100	121	142	—	90	—	—	20	—		
1049	= 510												
1050	Offset STEP = 9	A ₉	61	75	88	—	60	—	—	10	—	g	(3)
1051	A _{CODE} = 1		—	118	—	—	90	—	—	20	—		
1052	= 256		138	160	183	—	120	—	—	30	—		
1053	= 510												
1054	Offset STEP = 10	A ₁₀	97	115	133	—	90	—	—	20	—	g	(3)
1055	A _{CODE} = 1		—	158	—	—	120	—	—	30	—		
1056	= 256		173	201	229	—	150	—	—	40	—		
1057	= 510												
1058	Offset STEP = 11	A ₁₁	134	155	176	—	120	—	—	30	—	g	(3)
1059	A _{CODE} = 1		—	198	—	—	150	—	—	40	—		
1060	= 256		210	241	273	—	180	—	—	50	—		
1061	= 510												
1062	Offset STEP = 12	A ₁₂	170	195	221	—	150	—	—	40	—	g	(3)
1063	A _{CODE} = 1		—	238	—	—	180	—	—	50	—		
1064	= 256		246	281	317	—	210	—	—	60	—		
1065	= 510												
1066	Offset STEP = 13	A ₁₃	204	235	267	—	180	—	—	50	—	g	(3)
1067	A _{CODE} = 1		—	279	—	—	210	—	—	60	—		
1068	= 256		280	322	364	—	240	—	—	70	—		
1069	= 51												
1070	Offset STEP = 14	A ₁₄	240	275	310	—	210	—	—	60	—	g	(3)
1071	A _{CODE} = 1		—	319	—	—	240	—	—	70	—		
1072	= 256		317	362	408	—	270	—	—	80	—		
1073	= 510												
1074	Offset STEP = 15	A ₁₅	274	315	356	—	240	—	—	70	—	g	(3)
1075	A _{CODE} = 1		—	359	—	—	270	—	—	80	—		
1076	= 256		350	402	455	—	300	—	—	90	—		
1077	= 510												

2.3 ≤ V_{DD} ≤ 3.6, -20 °C ≤ T_A ≤ 85 °C, unless otherwise specified.

#	Characteristic	Symbol	All families			Units	
			Min	Typ	Max		
1078	Acceleration cross-axis sensitivity	A _{CROSS}	-5	—	5	%	(4)
1079	Acceleration sensitivity variation	ΔΔA _Z	-15	0	15	%	(4)
1080	Z-axis Acceleration Measurement						(3)
	Sensor measurement time (note 7)	t _{AM}	—	4.0	4.8	ms	(3)
1081	Peak current (note 8)	I _A	—	3.0	3.4	mA	(3)
	Power consumption						(3)
1082	Raw measurement, 10-bit	Q _C	—	2.1	3.6	μA-sec	(3)
1083	Compensation, 9-bit	Q _C	—	1.9	2.3	μA-sec	(3)
1084	Basic compensated reading, 9-bit	Q _C	—	4.0	6.0	μA-sec	(3)
1085	Full compensated reading, 9-bit	Q _C	—	4.4	6.0	μA-sec	(3)

17.11 LFR Sensitivity

$2.3 \leq V_{DD} \leq 3.6$, $-20 \text{ }^\circ\text{C} \leq T_A \leq 85 \text{ }^\circ\text{C}$, unless otherwise specified. Detection and no detection criteria defined by notes 19 and 20.

#	Characteristic	Symbol	Min	Typ	Max	Units	
1100	LFR Input Sensitivity in carrier mode, 125 kHz carrier, LFCDTM = 256 μ s UOS Very Low Sensitivity, SENS(1:0) = 00 Detect level, LFA:B	S_{DET_VL}	—	—	60	mV p-p	(4)
1101	No detect level, LFA:B	S_{NODET_VL}	24	—	—	mV p-p	(4)
1102	Low Sensitivity, SENS(1:0) = 00 Detect level, LFA:B	S_{DET_L}	—	—	14	mV p-p	(4)
1103	No detect level, LFA:B	S_{NODET_L}	2	—	—	mV p-p	(4)
1104	High Sensitivity, SENS[1:0] = 10, CHK125 = 01 Detect level, LFA:B	S_{DET_H}	—	—	3.5	mV p-p	(2)
1105	No detect level, LFA:B	S_{NODET_H}	0.5	—	—	mV p-p	(2)
1106	Sensitivity Shift in High Sensitivity, SENS[1:0] = 10, CHK125 = 00 Detect level, LFA:B, (typical difference observed between CHK125 = 00 and 01	S_{DET_H}	—	-0.12	—	mV p-p	(3)
1107	No detect level, LFA:B, No detect level, LFA:B (typical difference observed between CHK125 = 00 and 01)	S_{NODET_H}	—	-0.12	—	mV p-p	(3)
1108	LFR Input Sensitivity in data mode 125 kHz carrier, LFCDTM = 64 μ sec Valid reception of 10 consecutive frames of 16-bit Manchester bit preamble + 9T SYNC + 16-bit ID + 4 bytes of data. Continuously ON High Sensitivity, SENS[1:0] = 10, CHK125 = 01 Data detect level	S_{PER_H}	—	—	3.5	mV p-p	(2)
1109	Data no detect level	S_{NOPER_H}	0.25	—	—	mV p-p	(2)
1110	LFR Input Sensitivity in data mode 125 kHz carrier, LFCDTM = 64 μ sec Valid reception of 10 consecutive frames of 16-bit Manchester bit preamble + 9T SYNC + 16-bit ID + 4 bytes of data. Continuously ON Low Sensitivity, SENS[1:0] = 01, CHK125 = 00 Data detect level	S_{PER_L}	—	—	14	mV p-p	(3)
1111	Data no detect level	S_{NOPER_L}	2	—	—	mV p-p	(3)

Note: Refer to [page 169](#) for description of notes.

17.12 LFR Characteristics

$2.3 \leq V_{DD} \leq 3.6$, $-20 \text{ }^\circ\text{C} \leq T_A \leq 85 \text{ }^\circ\text{C}$, unless otherwise specified.

#	Characteristic	Symbol	Min	Typ	Max	Units	
1200	LF Input Signal Characteristics Relative to High Sensitivity Data Mode Always Detect, S_{PER_H} Dynamic Range, $DEQEN = 0$	V_{IN}	56	—	—	dB	(3)
1201	LFR Input Signal Characteristics (Manchester Data Mode) Modulation Depth (Data 1 - Data 0)/Data 1	M_R	70	—	100	%	(3)
1202	Data bit time	t_{DATA}	248	256	264	μsec	(3)
1203	Bit Duty Cycle	M_{DC}	45	—	55	%	(3)
1204	LFR Differential Input (LFA to LFB, Figure 122) Differential Resistance	R_{LDFD}	1	—	4	$M\Omega$	(3)
1205	Differential Capacitance (C_3)	C_{LDFD}	2	3.8	6	μF	(3)
1206	LFR Carrier Frequency Range $VALEN = 1$, $LFCDTM = 256 \mu\text{sec}$ Always accepted carrier	f_{LFC}	121.25	—	128.75	kHz	(3)
1207	Always rejected carrier, rejected frequencies upper limit	f_{LFCH}	—	—	80	kHz	(3)
1208	Always rejected carrier, rejected frequencies lower limit	f_{LFCL}	210	—	—	kHz	(3)
1209	$VALEN = 0$, $LFCDTM = 256 \text{ ms}$ High Cutoff Freq, 5 mV p-p input, $SENS[1:0] = 00$	f_{LFCO}	—	350	—	kHz	(4)
1210	LFR Detector Power Up Settling Time (2 LFO cycles)	t_{PU}	1.4	2.0	2.6	ms	(4)
1211	LFR Preamble Decoder Settling Time Data Mode Only, $LFCDTM$ plus t_{DEC} $LPSM = 0$	t_{DEC}	—	—	200	μsec	(4)
1212	$LPSM = 1$	t_{DEC}	—	—	400	μsec	(4)

Note: Refer to [page 169](#) for description of notes.

17.13 LFR Power Consumption

$2.3 \leq V_{DD} \leq 3.6$, $-20 \text{ }^\circ\text{C} \leq T_A \leq 85 \text{ }^\circ\text{C}$, unless otherwise specified. All parameters based upon $DEQEN = 0$ setting.

#	Characteristic	Symbol	Min	Typ	Max	Units	
1300	LFR Supply Current, Carrier Detect Mode Monitor for carrier with $VALEN = 0$, $LPSM = 1$ $T_A = 25 \text{ }^\circ\text{C}$, $3.0 \text{ V } V_{DD}$	I_{LFR}	—	3.9	—	μA	(3)
1301	$T_A = -40 \text{ }^\circ\text{C}$ to $125 \text{ }^\circ\text{C}$, 2.3 to $3.6 \text{ V } V_{DD}$		—	—	5.5		
1302	Frequency validation with $VALEN = 1$, $LPSM = 1$ and $CHK125 = 00$ $T_A = 25 \text{ }^\circ\text{C}$, $3.0 \text{ V } V_{DD}$	I_{LFR}	—	5.6	—	μA	(3)
1303	$T_A = -40 \text{ }^\circ\text{C}$ to $125 \text{ }^\circ\text{C}$, 2.3 to $3.6 \text{ V } V_{DD}$		—	—	7.5		
1304	Frequency validation with $VALEN = 1$, $LPSM = 1$ and $CHK125 = 01$ $T_A = 25 \text{ }^\circ\text{C}$, $3.0 \text{ V } V_{DD}$	I_{LFR}	—	5.8	—	μA	(1)
1305	$T_A = -40 \text{ }^\circ\text{C}$ to $125 \text{ }^\circ\text{C}$, 2.3 to $3.6 \text{ V } V_{DD}$		—	—	8.0		
1306	LFR Supply Current, Manchester Data Mode Decoding of data stream after carrier detected $T_A = 25 \text{ }^\circ\text{C}$, $3.0 \text{ V } V_{DD}$	I_{LFR}	—	11.8	—	μA	(3)
1307	$T_A = -40 \text{ }^\circ\text{C}$ to $125 \text{ }^\circ\text{C}$, 2.3 to $3.6 \text{ V } V_{DD}$		—	—	13.5		

Note: Refer to [page 169](#) for description of notes.

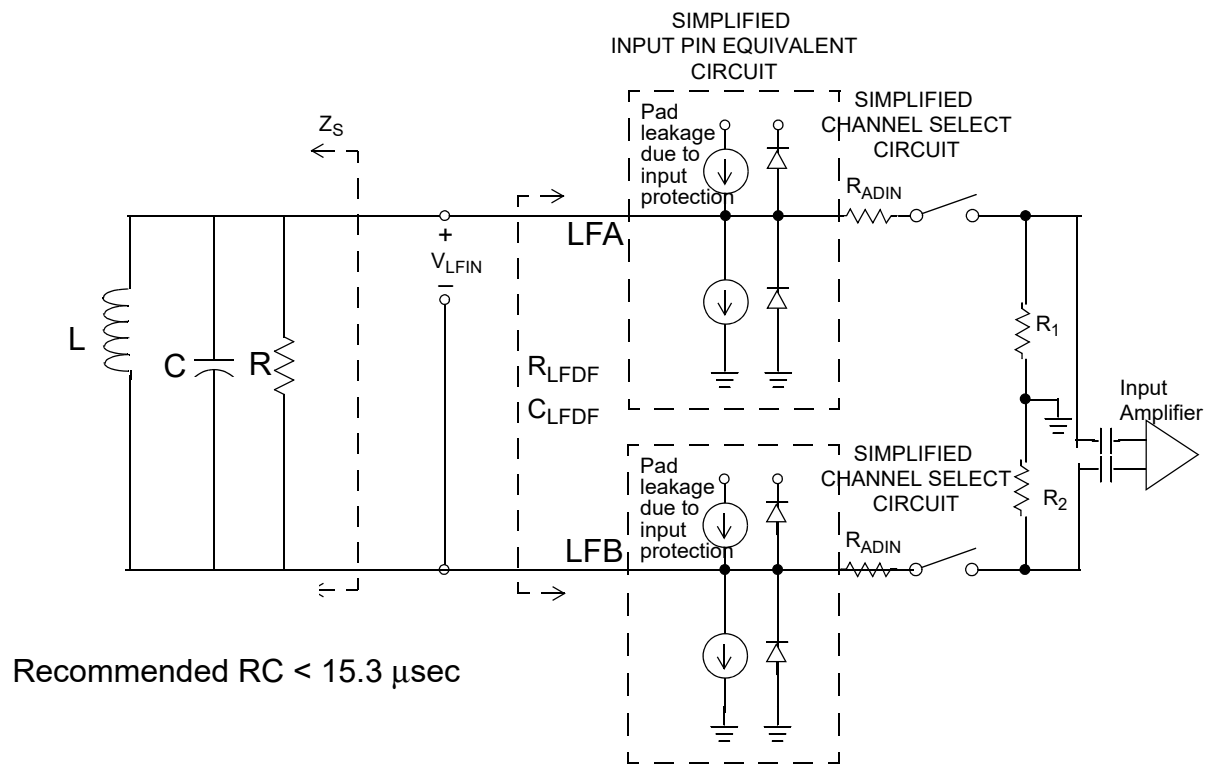

Figure 122. LFR Detector Input Equivalent Circuit

17.14 RF Output Stage

$1.8 \leq V_{DD} \leq 3.6$, $T_L \leq T_A \leq T_H$, unless otherwise specified.

Power output based on using Dynamic RF Power Correction firmware routine.

Output load of 50Ω resistance as shown in [Figure 125](#) unless otherwise specified.

MCU in STOP1 mode during all RF tests.

RF output will shutdown when the total RF I_{DD} causes V_{DD} to fall below 1.8 V ($V_{DD} = V_{BATT} - I_{BATT} \times R_{BATT}$). See [Figure 126](#).

#	Characteristic	Symbol	Min	Typ	Max	Units	
1400	Nominal Output Power with 50Ω matching network (note 21) 315 MHz, $T_A = 25^\circ\text{C}$, $V_{DD} = 3\text{ V}$, PWR[4:0] = 01110	P_{RF}	4.0	5.2	6.0	dBm	(1)
1401	434 MHz, $T_A = 25^\circ\text{C}$, $V_{DD} = 3\text{ V}$, PWR[4:0] = 01111	P_{RF}	3.5	4.9	6.0	dBm	(1)
1402*	Nominal Output Power with 50Ω matching network at maximum power step, PWR[4:0] = 10100. Temperature and voltage range defined by Figure 123 and Figure 124 .	P_{RF}	3	—	—	dBm	(3)
1403	Programmable Power Adjustment PWR[4:0] = 00000 through 11111 Low Power Mode (PWR[4:0] = 00000)	P_{LPM}	—	-10	—	dBm	(3)
1404	Range (nominal, (PWR[4:0] > 00000))	P_{RF}	-1.5	—	8.0	dBm	(3)
1405	Adjustment step (-1.5 to +8 dBm)	P_{ADJ}	—	0.5	—	dBm	(3)
1406	Programmable Frequency Steps Carrier & FSK Deviation (AFREQ[12:0] and BFREQ[12:0])	f_{STEP}	—	3.174	—	kHz	(3)
1407	External Crystal Frequency (note 14)	f_{XTAL}	—	26.000	—	MHz	(3)
1408	Fixed portion of RF start process,	t_{S-RCTS}	—	—	300	μsec	(3)
1409	Variable portion of RF start process	Bits	—	3	—	bit times	(4)
1410	Total RF transmit start time from write of SEND bit to start of RF @ 2,000 bps $t_{RF} = t_{S-RCTS} + (\text{Bits} \times \text{bps}^{-1})$	t_{RF2}	—	—	1.8	ms	(3)
1411	Total RF transmit start time from write of SEND bit to start of RF @ 9,600 bps $t_{RF} = t_{S-RCTS} + (\text{Bits} \times \text{bps}^{-1})$	$t_{RF9.6}$	—	—	613	μsec	(3)
1412	Total RF transmit start time from write of SEND bit to start of RF @ 20,000 bps $t_{RF} = t_{S-RCTS} + (\text{Bits} \times \text{bps}^{-1})$	t_{RF20}	—	—	450	μsec	(3)
1413	OOK Modulation Depth	M_{OOK}	50	—	—	dBc	(3)
1414	Manchester Encoding Data Rate Bit Rate Dependent on accuracy of MFO (note 18).	DR	—	—	± 5	%	(3)
1415	Modulation Duty-Cycle (OOK and FSK)	DC	45	50	55	%	(3)
1416	XTAL Oscillator Margin (over 26 MHz) (note 17)	ML	600	—	—	Ω	(4)
1417	Harmonic 2 Level (315 and 434 MHz bands, with matching reference network) $V_{DD} = 3\text{ V}$, $T_A = 25^\circ\text{C}$, PWR[4:0] = 01110	H2	—	-35	-22	dBc	(3)
1418	$1.8 \leq V_{DD} \leq 3.6$, $T_L \leq T_A \leq T_H$, power step adjusted to reach the targeted power in each domain	H2	—	-25	-20	dBc	(3)
1419	Harmonic 4 Level and above (315 and 434 MHz bands, with matching reference network) $V_{DD} = 3\text{ V}$, $T_A = 25^\circ\text{C}$, PWR[4:0] = 01110	H4	—	—	-30	dBc	(3)
1420	$1.8 \leq V_{DD} \leq 3.6$, $T_L \leq T_A \leq T_H$, power step adjusted to reach the targeted power in each domain	H4	—	—	-30	dBc	(3)

#	Characteristic	Symbol	Min	Typ	Max	Units	
1421	Harmonic 3 Level (315 and 434 MHz bands, with matching reference network) $V_{DD} = 3\text{ V}$, $T_A = 25\text{ }^\circ\text{C}$, $PWR[4:0] = 01110$	H3	—	-31	-28	dBc	(3)
1422	$1.8 \leq V_{DD} \leq 3.6$, $T_L \leq T_A \leq T_H$, power step adjusted to reach the targeted power in each domain	H3	—	-27	-25	dBc	(3)
1423	Noise for BOOST = 0 Phase Noise (315 MHz) $f_{RF} \pm 10\text{ kHz}$	N_{PH}	—	-86	-78	dBc/Hz	(3)
1424	$f_{RF} \pm 100\text{ kHz}$	N_{PH}	—	-92	-86	dBc/Hz	(3)
1425	$f_{RF} \pm 1\text{ MHz}$	N_{PH}	—	-84	-82	dBc/Hz	(3)
1426	Phase Noise (434 MHz) $f_{RF} \pm 10\text{ kHz}$	N_{PH}	—	-84	-76	dBc/Hz	(3)
1427	$f_{RF} \pm 100\text{ kHz}$	N_{PH}	—	-89	-83	dBc/Hz	(3)
1428	$f_{RF} \pm 1\text{ MHz}$	N_{PH}	—	-82	-80	dBc/Hz	(3)
1429	Spurious Noise (315 and 434 MHz bands) $f_{RF} \pm f_{REF}$	N_{SPUR}	—	-45	-40	dBc	(3)
1430	Occupied Bandwidth (Korea, MIC 2007-63) For FSK up to $\pm 45\text{ kHz}$ and 9600 bit/sec and for OOK up to 9600 bit/sec Analyzed setup: RBW = VBW up to 10 kHz, Span up to 1.25 MHz, and MaxHold	OBW_K	—	—	180	kHz	(3)
1431	Noise for BOOST = 1 Phase Noise (315 MHz) $f_{RF} \pm 10\text{ kHz}$	N_{PH}	—	-75	-67	dBc/Hz	(3)
1432	$f_{RF} \pm 100\text{ kHz}$	N_{PH}	—	-80	-76	dBc/Hz	(3)
1433	$f_{RF} \pm 1\text{ MHz}$	N_{PH}	—	-95	-93	dBc/Hz	(3)
1434	Spurious Noise (315 MHz bands) $f_{RF} \pm f_{REF}$	N_{SPUR}	—	-45	-40	dBc	(3)
1435	Occupied Bandwidth (Japan, ARIB STD-T93) For FSK up to $\pm 45\text{ kHz}$ and 9600 bit/sec	OBW_J	—	—	400	kHz	(3)
1436	For OOK up to 9600 bit/sec Analyzed setup: RBW = VBW up to 30 kHz, Span up to 3.5 MHz, and MaxHold	OBW_J	—	—	600	kHz	(3)
1437	RF Oscillator Frequency Accuracy, XCO (note 21) excluding external crystal and component variations	f_{XCO}	-30	—	+30	ppm	(3)

* FSL D-FMEA class 306.

Note: Refer to [page 169](#) for description of notes.

17.15 Power Consumption RF Transmissions

$1.8 \leq V_{DD} \leq 3.6$, $T_A = 25^\circ\text{C}$ unless otherwise specified.

#	Characteristic	Symbol	Min	Typ	Max	Units
1500	RF Supply Transmission Current $V_{DD} = 3.0\text{ V}$, PWR[4:0] set for nominal 5 dBm 315 MHz Power delta for BOOST = 1 315 MHz Carrier Frequency, BOOST = 0	ΔI_{DD}	—	—	0.55	mA (2)
1501	Data 1, FSK or OOK 434 MHz Carrier Frequency, BOOST = 0	I_{DD}	—	6.0	7.0	mA (1)
1502	Data 1, FSK or OOK	I_{DD}	—	6.6	7.6	mA (1)
1503	Interframe period, IFPD = 0.	I_{DD}	—	617	696	μA (3)
1504	Interframe period, IFPD = 0, $1.8 \leq V_{DD} \leq 3.6$, $TL \leq TA \leq TH$	I_{DD}	—	—	789	μA (3)
1505	Interframe period, IFPD = 1, DRLPEN = 1, $1.8 \leq V_{DD} \leq 3.6$, $TL \leq TA \leq TH$	I_{DD}	—	20	29	μA (3)
1506	Interframe period, IFPD = 1, DRLPEN = 0	I_{DD}	—	77	96	μA (3)
1507	Interframe period, IFPD = 1, DRLPEN = 0, $1.8 \leq V_{DD} \leq 3.6$, $TL \leq TA \leq TH$	I_{DD}	—	—	125	μA (3)

Note: Refer to [page 169](#) for description of notes.

Using the TPMS_RF_DYNAMIC_POWER firmware routine (see [Section 14](#)) allows adjusting power step in order to compensate variations of output power versus temperature and voltage. This routine will be associated to a part to part trimming that initially adjusts the power step to compensate for process variations.

Both these trim and look-up table allow to guarantee by characterization the typical values of power consumption as presented below (average values among 100 parts plus improvements prediction from design).

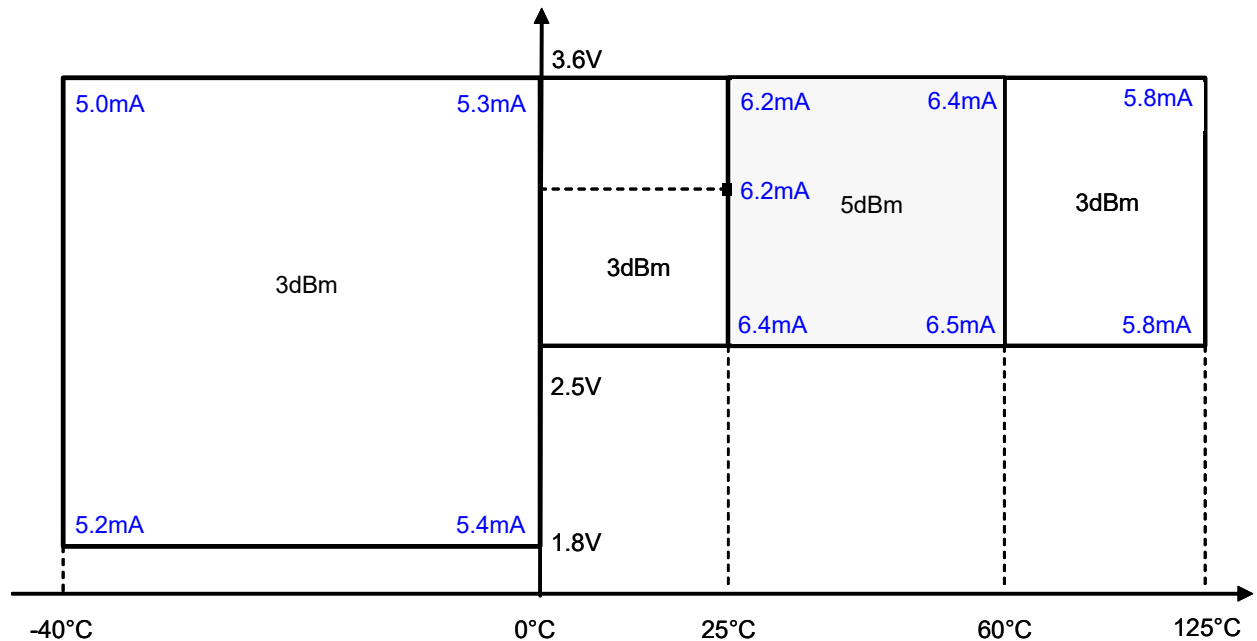

Figure 123. Dynamic Power Adjustment - 315 MHz

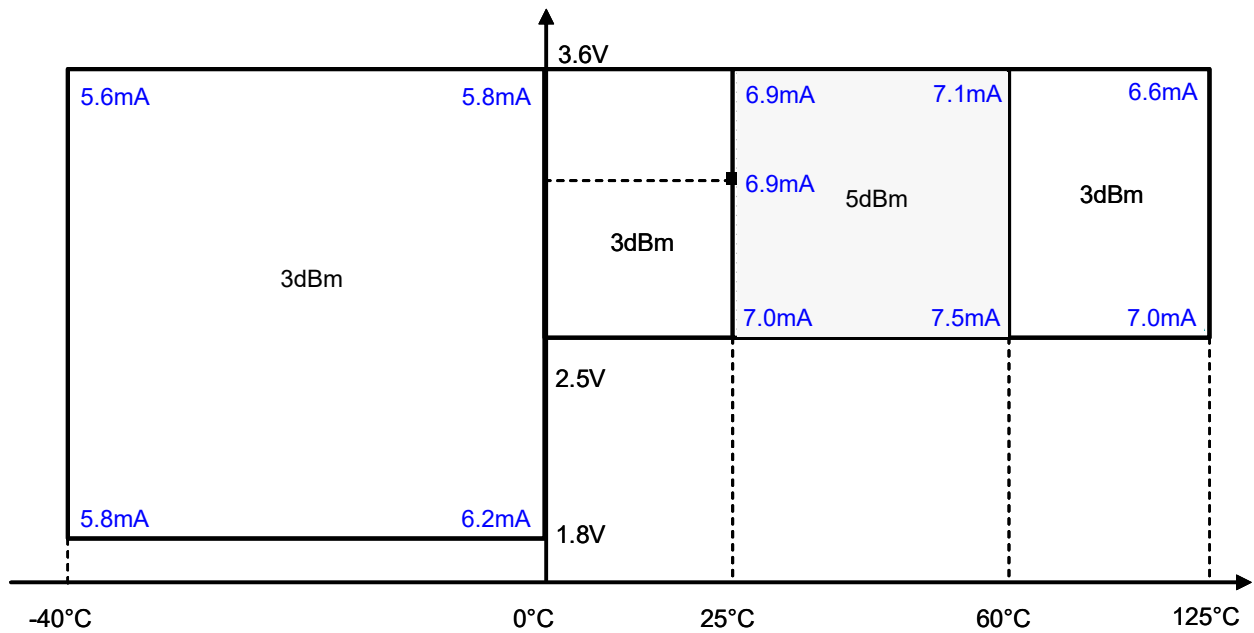

Figure 124. Dynamic Power Adjustment - 434 MHz

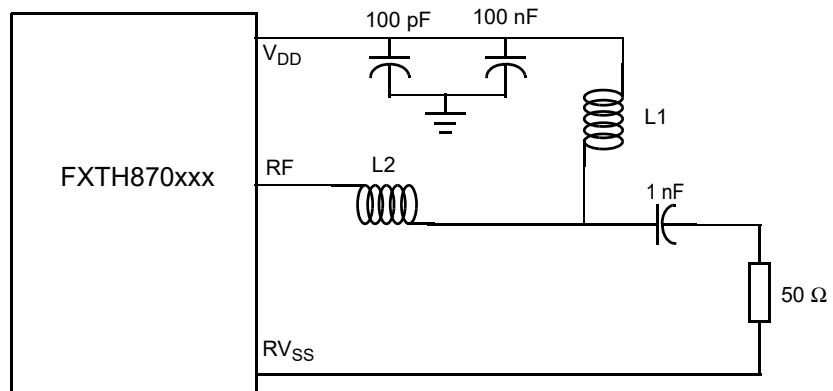

Figure 125. RF Output Power Measurement Configuration

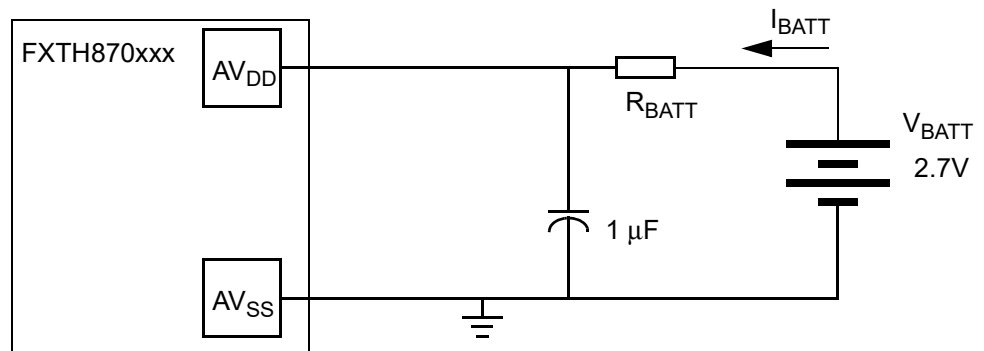

Figure 126. Battery Performance Test Configuration

18 Mechanical Specifications

18.1 Maximum Ratings

Maximum ratings are the extreme limits to which the device can be exposed without permanently damaging it. The device contains circuitry to protect the inputs against damage from high static voltages; however, do not apply voltages higher than those shown in the table below. Keep V_{IN} and V_{OUT} within the range $V_{SS} \leq (V_{IN} \text{ or } V_{OUT}) \leq V_{DD}$.

#	Rating	Symbol	Value	Unit	
1800	Maximum Pressure (absolute)				(3)
1801	Continuous	p_{max}	1500	kPa	(3)
	Pulsed, 5 seconds, 25 °C	p_{max}	2000	kPa	(3)
1802	Centrifugal Force Effects (Z-axis)				(3)
	Sustained acceleration (Z-axis)	g_{CENT}	2600	g	(3)
1803	Powered Shock (peak, 0.1 ms, half-sine, 6-axis)	g_{shock}	6000	g	(3)
1804	Drop Test (onto concrete, unpowered)	h_{DROP}	1.2	m	(3)
1805	Pressure Sensor Resonance				(4)
1806	Resonant frequency	f_{P0}	5.5	MHz	(4)
	Damping Ratio	Q_P	1		(4)
1807	Optional X-axis Accelerometer Sensor Resonance				(4)
1808	Resonant frequency (no-peak, over-damped)	f_{X0}	12.5	kHz	(4)
1809	Damping Ratio	Q_X	0.1		(4)
	Maximum acceleration before limit stops are reached	g_{MAX}	180	g	(4)
1810	Optional Z-axis Accelerometer Sensor Resonance				(4)
1811	Resonant frequency (no-peak, over-damped)	f_{Z0}	9	kHz	(4)
1812	Damping Ratio	Q_Z	5		(4)
	Maximum acceleration before limit stops are reached	g_{MAX}	800	g	(4)
1813	Package Weight	w	0.30	gm	(3)

Note: Refer to [page 169](#) for description of notes.

18.2 Media Compatibility

Media compatibility is based on media and test method described in NXP specification 12MWS10081G, Media Test for TPMS MCM Automotive Pressure Sensors. Consult your sales representative for more details and specific requirements.

18.3 Mounting Recommendations

The package should be mounted with the pressure port pointing away from the axis of tire rotation so that centrifugal force will propel any contaminants out of the pressure port. In cases where the application must orient the pressure port pointing inward, care must be taken to assure contaminants do not reach inside the pressure port.

A plugged port will exhibit no change in pressure and can be cross checked in the user's software using the method described in [Section 10.1](#).

Please refer to application note AN1902 for proper printed circuit board attributes and recommendations.

Notes:

1. Parameters tested 100% at final test.
2. Parameters tested 100% at unit probe.
3. Verified by characterization, not tested in production.
4. For information only, may be determined by simulation.
5. Total of three hours over the life of the device.
6. Fully compensated pressure reading using TPMS_READ_PRESSURE followed by TPMS_COMP_PRESSURE routine with single reading and 500 Hz low-pass filter ON.
7. Measurement times for one complete compensated reading; and times dependent on clock tolerances.
8. Peak currents measured as the current over 10 MCU bus cycles immediately after the ADC wakes up the MCU using the external network shown in [Figure 126](#) with R_{BATT} equal to zero-ohm resistance.
9. Fully compensated acceleration reading using TPMS_READ_ACCELERATION followed by TPMS_COMP_ACCELERATION routine with single reading and 500 Hz low-pass filter ON.
10. Total range of variation over 30 consecutive measurements, using compensated output format.
11. Temperature error for MCU or RFM powered up at less the 10% duty-cycle
12. Package mounted with pressure port facing radially outward from axis of rotation.
13. Temperature shutdown points trimmed at final test. Limits when TRH (\$180F bits 6:4) overwritten by customer application to 0x06.
14. Suggested crystal is NDK NX3225SA, 26.000 MHz.
15. Low voltage detection and warning thresholds defined for voltage change rates less than 20 mV/ μ s. Hysteresis thresholds may decrease above 85 °C.
16. Response time to VDD of more than 100 mV below the minimum VDD falling threshold.
17. Crystal oscillator margin is the value of the total series resistance including the XTAL ESR, that can be applied before the XCO does not start up. This definition does not define any specific start up time.
18. Accuracy of the RF data rate when using the data buffer is dependent on the overall oscillator function (i.e. including external crystal and internal circuit tolerances).
19. LFR detection is tested to assure > 90% message success rate. LFR no detection is tested to assure < 10% message success rate. In carrier detect mode the applied input pulse is at least 2x the LFCDTM selected. In all cases the envelop of the input waveform must have a RC time constant less than 15.3 μ sec. LF sensitivity limits are measured while the device is in the STOP1 mode, which is characterized as a worst-case condition; sensitivity in the other modes are improved versus the STOP1 modes.
20. Using firmware release \$28 or higher for FXTH870x02, FXTH870x11 and FXTH870x12; using firmware release \$11 for FXTH870x22.
21. Actual final test value degraded by losses in the tester. Correlation study done as characterization to infer actual value.
22. Power consumption values refer to the firmware data flow in [Figure 57](#). The BASIC Compensated value includes just the raw measurement and compensation routine for that parameter. Other raw readings needed for full compensation will be pulled from the UUMA. The FULL Compensated value includes taking all required raw readings and using the compensation routine for that parameter.

19 Package Outline

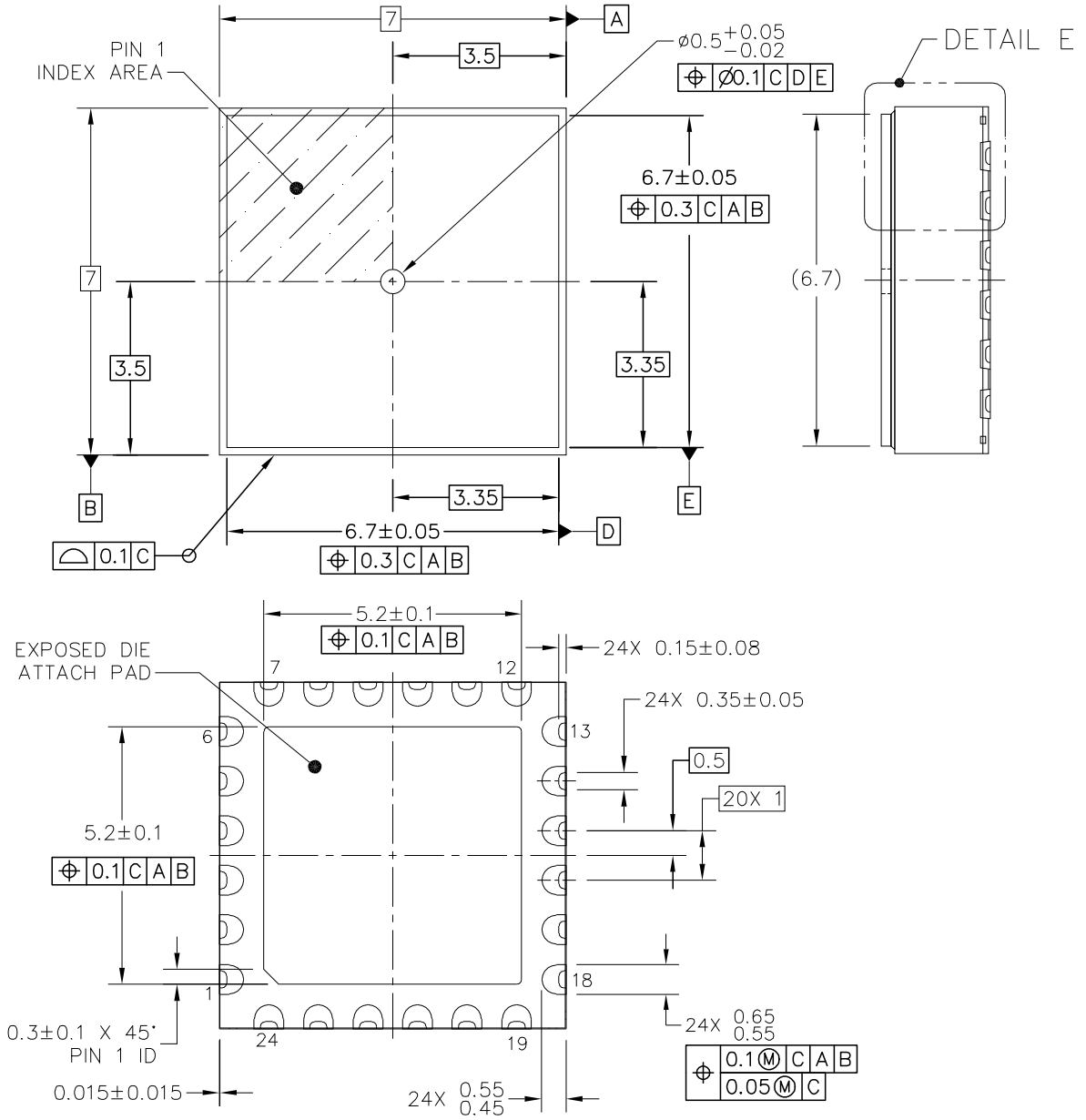

© NXP SEMICONDUCTORS N.V. ALL RIGHTS RESERVED	MECHANICAL OUTLINE	PRINT VERSION NOT TO SCALE
TITLE: QFN, THERMALLY ENHANCED, 7 X 7 X 2.2, 1.0 PITCH, 24 TERMINAL	DOCUMENT NO: 98ASA00432D	REV: H
	STANDARD: NON-JEDEC	
	SOT1575-1	08 JAN 2016

Figure 127. QFN Case Outline

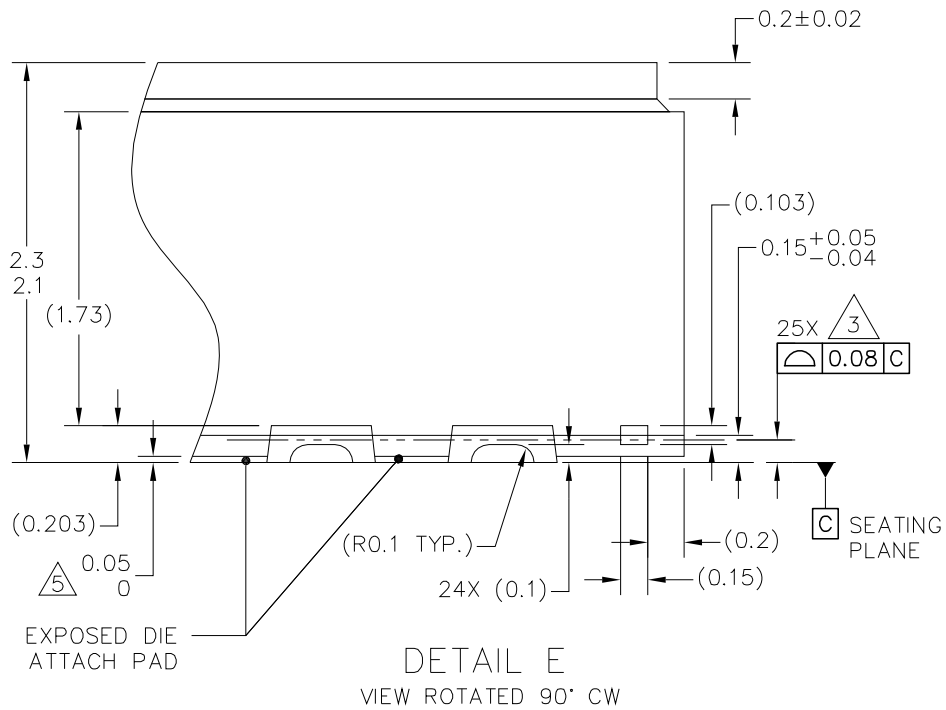

© NXP SEMICONDUCTORS N.V. ALL RIGHTS RESERVED	MECHANICAL OUTLINE	PRINT VERSION NOT TO SCALE	
TITLE: QFN, THERMALLY ENHANCED, 7 X 7 X 2.2, 1.0 PITCH, 24 TERMINAL	DOCUMENT NO: 98ASA00432D	REV: H	
	STANDARD: NON-JEDEC		
	SOT1575-1	08 JAN 2016	

Figure 128. QFN Case Outline



NOTES:

1. DIMENSIONS ARE IN MILLIMETERS.
2. INTERPRET DIMENSIONS AND TOLERANCES PER ASME Y14.5M-1994.
3. COPLANARITY APPLIES TO LEADS, AND DIE ATTACH PAD.
4. MIN METAL GAP SHOULD BE 0.2MM.
5. THIS DIMENSION APPLIES ONLY FOR TERMINALS.

© NXP SEMICONDUCTORS N.V. ALL RIGHTS RESERVED	MECHANICAL OUTLINE	PRINT VERSION NOT TO SCALE	
TITLE: QFN, THERMALLY ENHANCED, 7 X 7 X 2.2, 1.0 PITCH, 24 TERMINAL		DOCUMENT NO: 98ASA00432D	REV: H
		STANDARD: NON-JEDEC	
		SOT1575-1	08 JAN 2016

Figure 129. QFN Case Outline

20 Revision History

Document number	Date	Supersedes
FXTH870x6 v.1.7	02/2019	FXTH870x6 v.1.6
Modifications	<ul style="list-style-type: none"> • Section 2.2: Revised as follows: <ul style="list-style-type: none"> – Moved Figure 5 from Section 2.3 to Section 2.2. – Figure 5: Updated the image for Figure 5, removing the asterisk next to “C4” in the image and the corresponding paragraph embedded below in the image. – Inserted the paragraph removed from Figure 5 into the narrative of Section 2.2 and revised the paragraph. – Inserted a second paragraph and a note as the last paragraph of Section 2.2. 	
FXTH870x6 v.1.6	08/2017	FXTH870x6 v.1.5
FXTH870x6 v.1.5	02/2015	FXTH870x6 v.1.4
FXTH870x6 v.1.4	01/2015	FXTH870x6 v.1.3
FXTH870x6 v.1.3	09/2014	FXTH870x6 v.1.2
FXTH870x6 v.1.2	08/2014	FXTH870x6 v.1.1
FXTH870x6 v.1.1	07/2014	FXTH870x6 v.1
FXTH870x6 v.1	07/2014	FXTH870x6 v.0
FXTH870x6 v.0	05/2014	—



How to Reach Us:

Home Page:
[NXP.com](http://www.nxp.com)

Web Support:
<http://www.nxp.com/support>

Information in this document is provided solely to enable system and software implementers to use NXP products. There are no expressed or implied copyright licenses granted hereunder to design or fabricate any integrated circuits based on the information in this document. NXP reserves the right to make changes without further notice to any products herein.

NXP makes no warranty, representation, or guarantee regarding the suitability of its products for any particular purpose, nor does NXP assume any liability arising out of the application or use of any product or circuit, and specifically disclaims any and all liability, including without limitation, consequential or incidental damages. "Typical" parameters that may be provided in NXP data sheets and/or specifications can and do vary in different applications, and actual performance may vary over time. All operating parameters, including "typicals," must be validated for each customer application by the customer's technical experts. NXP does not convey any license under its patent rights nor the rights of others. NXP sells products pursuant to standard terms and conditions of sale, which can be found at the following address:

<http://www.nxp.com/terms-of-use.html>.

NXP, the NXP logo, Freescale, the Freescale logo, CodeWarrior, and the Energy Efficient Solutions logo are trademarks of NXP B.V. All other product or service names are the property of their respective owners. All rights reserved.

© 2019 NXP B.V.

Document Number: FXT870x6
Rev. 1.7
02/2019

